

Datasheet - AES 1235



Guard door monitors and Safety control modules for Emergency Stop applications / Micro Processor based safety controllers (Series AES) / AES 123x

Preferred typ



- Monitoring of BNS range magnetic safety sensors
- 2 safety contacts, STOP 0
- 2 Signalling outputs

(Minor differences between the printed image and the original product may exist!)

Ordering details

Product type description	AES 1235
Article number	101170049
EAN Code	4030661297118
eCl@ss	27-37-19-01

Approval

Approval

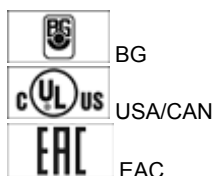

Classification

Standards	EN ISO 13849-1, IEC 61508
PL	up d
Control category	up 3
PFH value	1.0 x 10 ⁻⁷ /h
- notice	up to max. 50.000 switching cycles/year and at max. 80% contact load
SIL	2
Mission time	20 Years

Global Properties

Permanent light	AES 123x
Standards	IEC/EN 60204-1, IEC 60947-5-3, IEC 61508, BG-GS-ET-14, BG-GS-ET-20
Compliance with the Directives (Y/N) 	Yes
Climatic stress	EN 60068-2-3, BG-GS-ET-14
Mounting	snaps onto standard DIN rail to EN 60715
Terminal designations	IEC/EN 60947-1
Materials	
- Material of the housings	Plastic, glass-fibre reinforced thermoplastic, ventilated
- Material of the contacts	Ag-Ni, 0,2 µm gold flashed
Weight	160
Start conditions	Automatic or Start button
Start input (Y/N)	No
Feedback circuit (Y/N)	Yes
Start-up test (Y/N)	No
Reset after disconnection of supply voltage (Y/N)	Yes
Automatic reset function (Y/N)	Yes
Reset with edge detection (Y/N)	No
Pull-in delay	
- ON delay with automatic start	adjustable 0,1 / 1.0 s
Drop-out delay	
- Drop-out delay in case of emergency stop	< 50

Mechanical data

Connection type	Screw connection
Cable section	
- Min. Cable section	0,25
- Max. Cable section	2.5
Pre-wired cable	rigid or flexible
Tightening torque for the terminals	0,6
Detachable terminals (Y/N)	No
Mechanical life	20.000.000 operations
Electrical lifetime	150.000 operations for 230 VAC, 5 A (cos φ = 1)
resistance to shock	30 g / 11 ms
Resistance to vibration To EN 60068-2-6	10...55 HZ, Amplitude 0,35 mm, ± 15 %

Ambient conditions

Ambient temperature	
- Min. environmental temperature	0
- Max. environmental temperature	+55
Storage and transport temperature	
- Min. Storage and transport temperature	-25
- Max. Storage and transport temperature	+70
Protection class	
- Protection class-Enclosure	IP40
- Protection class-Terminals	IP20
- Protection class-Clearance	IP54
Air clearances and creepage distances To IEC/EN 60664-1	
- Rated impulse withstand voltage U _{imp}	4.8 kV

- Overvoltage category	III To VDE 0110
- Degree of pollution	2 To VDE 0110

Electromagnetic compatibility (EMC)

EMC rating	10 V/m
------------	--------

Electrical data

Rated DC voltage for controls	
- Max. rated DC voltage for controls	20.4
- Max. rated DC voltage for controls	27.6
Rated AC voltage for controls, 50 Hz	
- Min. rated AC voltage for controls, 50 Hz	-
- Max. rated AC voltage for controls, 50 Hz	-
Rated AC voltage for controls, 60 Hz	
- Min. rated AC voltage for controls, 60 Hz	-
- Max. rated AC voltage for controls, 60 Hz	-
Contact resistance	max. 100 mΩ
Power consumption	< 5
Type of actuation	DC
Switch frequency	1
Rated insulation voltage U_i	250 V
Rated operating voltage U_e	24 VDC $\pm 15\%$
Thermal test current I_{the}	6 A
Operating current I_e	0,2 A
Electronic protection (Y/N)	No

Inputs

Monitored inputs

- Short-circuit recognition (Y/N)	optional
- Wire breakage detection (Y/N)	Yes
- Earth connection detection (Y/N)	Yes
Number of shutters	adjustable 1 - >0
Number of openers	adjustable 1 - >2
Input resistance	approx. 4000 Ω at GND
Input signal "1"	10 ... 30 VDC
Input signal "0"	0 ... 2 VDC
Cable length	1000 m with 0,75 mm ² (for Rated voltage)

Outputs

Stop category	0
Number of safety contacts	2
Number of auxiliary contacts	0
Number of signalling outputs	2
Switching capacity	
- Switching capacity of the safety contacts	min. 10 mA, max. 6 A
- Switching capacity of the signaling/diagnostic outputs	min. $U_e - 4V$ / Y1, Y2: max. 100 mA
Fuse rating	
- Protection of the safety contacts	6 A gG D-fuse
- Fuse rating for the signaling/diagnostic outputs	short-circuit proof, p-type
Signalling output	Y1: Authorized operation, safety contacts on;

2 YNo authorised operation off., safety contacts

Utilisation category To EN 60947-5-1

AC-15: 230 V / 3 A

DC-13: 24 V / 2 A

Number of undelayed semi-conductor outputs with signaling function	2
Number of undelayed outputs with signaling function (with contact)	0
Number of delayed semi-conductor outputs with signaling function.	0
Number of delayed outputs with signalling function (with contact).	0
Number of secure undelayed semi-conductor outputs with signaling function	0
Number of secure, undelayed outputs with signaling function, with contact.	0
Number of secure, delayed semi-conductor outputs with signaling function	0
Number of secure, delayed outputs with signaling function (with contact).	0

LED switching conditions display

LED switching conditions display (Y/N)	Yes
Number of LED's	1

Integral system diagnosis \$missingShortName\$

Integral system diagnosis ISD

- The following faults are registered by the safety monitoring modules and indicated by ISD
- Failure of door contacts to open or close
- Cross-wire or short-circuit monitoring of the switch connections
- Interruption of the switch connections
- Failure of the safety relay to pull-in or drop-out
- Fault on the input circuits or the relay control circuits of the safety monitoring module

Miscellaneous data

Applications



Safety sensor



Guard system

Dimensions

Dimensions

- Width	22.5 mm
- Height	100 mm
- Depth	121 mm

notice

Inductive loads (e.g. contactors, relays, etc.) are to be suppressed by means of a suitable circuit.

notice - Wiring example

To secure a guard door up to PL 3 and Category #03#

Monitoring 1 guard door(s), each with a magnetic safety sensor of the BNS range

The feedback circuit monitors the position of the contactors K3 and K4.

Start push button A start push button (NO) can optionally be connected into the feedback circuit. With the guard door closed, the enabling paths are then not closed until the start push button has been operated.

If neither start button nor feedback circuit are connected, a jumper connection must be mounted between X1 and A1.

If only one external relay or contactor is used to switch the load, the system can be classified in Control Category 3 to EN 954-1, if exclusion of the fault "Failure of the external contactor" can be substantiated and is documented, e.g. by using a reliable down-rated contactor. A second contactor leads to an increase in the level of security by redundant switching to switch the load off.

Modification for 2 NC contacts:

The safety monitoring module can be modified to monitor two NC contacts by bridging the terminals A1 and X2. The short-circuit recognition between connections then becomes inoperative.

Expansion of enable delay time:

The enable delay time can be increased from 0,1 s to 1 s by changing the position of a jumper link connection under the cover of the unit.

The wiring diagram is shown with guard doors closed and in de-energised condition.

The ISD tables (Integral System Diagnostics) for analysis of the fault indications and their causes are shown in the appendix.

Documents

Operating instructions and Declaration of conformity (de) 215 kB, 15.11.2017

Code: mrl_aes_1235_1236_de

Operating instructions and Declaration of conformity (it) 253 kB, 11.01.2018

Code: mrl_aes_1235_1236_it

Operating instructions and Declaration of conformity (jp) 314 kB, 18.01.2013

Code: mrl_aes_1235_1236_jp

Operating instructions and Declaration of conformity (en) 251 kB, 15.11.2017

Code: mrl_aes_1235_1236_en

Operating instructions and Declaration of conformity (da) 211 kB, 18.01.2013

Code: mrl_aes_1235_1236_da

Operating instructions and Declaration of conformity (fr) 254 kB, 08.01.2018

Code: mrl_aes_1235_1236_fr

Operating instructions and Declaration of conformity (es) 252 kB, 21.12.2017

Code: mrl_aes_1235_1236_es

Operating instructions and Declaration of conformity (pl) 267 kB, 02.05.2018

Code: mrl_aes_1235_1236_pl

Operating instructions and Declaration of conformity (nl) 251 kB, 11.07.2018

Code: mrl_aes_1235_1236_nl

Operating instructions and Declaration of conformity (br) 426 kB, 12.07.2010

Code: mrl_aes_1235_1236_br

Operating instructions and Declaration of conformity (sv) 208 kB, 18.01.2013

Code: mrl_aes_1235_1236_sv

Operating instructions and Declaration of conformity (pt) 256 kB, 11.01.2018

Code: mrl_aes_1235_1236_pt

Operating instructions and Declaration of conformity (cs) 254 kB, 18.01.2013

Code: mrl_aes_1235_1236_cs

Wiring example (99) 20 kB, 22.08.2008

Code: kaes1141

Wiring example (99) 20 kB, 22.08.2008

Code: Maes1111

ISD tables (Intergral System Diagnostics) (de) 51 kB, 29.07.2008

Code: i_ae2p01

ISD tables (Intergral System Diagnostics) (en) 35 kB, 29.07.2008

Code: i_ae2p02

BG-test certificate (en) 756 kB, 27.08.2018

Code: z_135p02

BG-test certificate (de) 768 kB, 27.08.2018

Code: z_135p01

BG-test certificate (en) 1 MB, 17.08.2018

Code: z_113p02

BG-test certificate (de) 1 MB, 17.08.2018

Code: z_113p01

EAC certification (ru) 1 MB, 15.03.2018

Code: q_aesp01

Images



Product photo

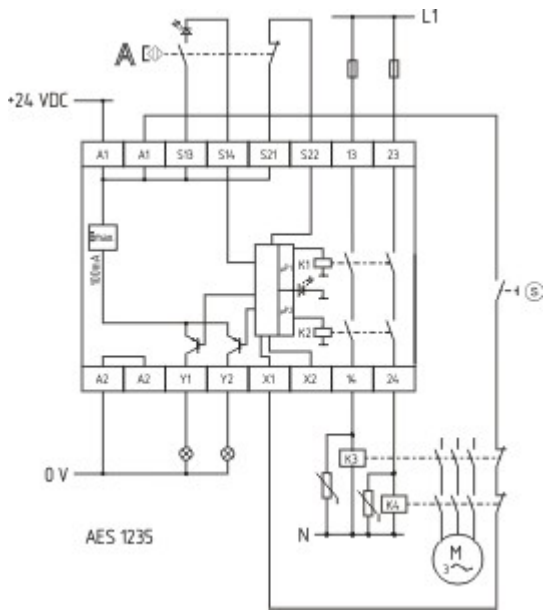

Wiring example

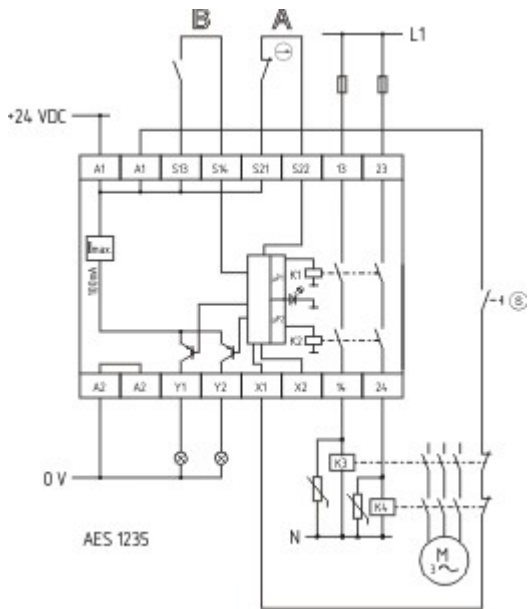

Wiring example

K.A. Schmersal GmbH & Co. KG, Möddinghofe 30, D-42279 Wuppertal

The data and values have been checked thoroughly. Technical modifications and errors excepted.

Generiert am 13.02.2019 - 13:04:43h Kasbase 3.3.0.F.64I