

Datasheet - M. 441-11Y-243

Belt alignment switch / 441 Belt alignment switch



(Minor differences between the printed image and the original product may exist!)

- Metal enclosure
- 2 Contacts
- 106 mm x 99 mm x 63 mm (basic component)
- Suitable for heavy duty
- 2 cable entries M20
- Continuous adjustment of lever position 360°

Ordering details

Product type description	M. 441-11Y-243
Article number	101168784
EAN Code	4030661224435
eCl@ss	27-27-06-01

Approval

Approval



Global Properties

Permanent light	441 Bandschieflaufschalter
Standards	EN 60947-5-1
Compliance with the Directives (Y/N) 	Yes
Suitable for safety functions (Y/N)	No
Standard housing (Y/N)	No
Materials	
- Material of the housings	cast iron, galvanized
- Material of the contacts	Silver
Housing coating	painted
Weight	1780

Mechanical data

Design of electrical connection	Screw connection
Cable section	
- Min. Cable section	1.5
- Max. Cable section	2.5
Active principle	mechanical
Mechanical life	10.000.000 operations
Switching frequency	3000
Contact opening	2 x 2.5
Actuation direction	each time 60° right-hand side and left-hand side rotation

Ambient conditions

Ambient temperature	
- Min. environmental temperature	-30
- Max. environmental temperature	+90
Protection class	IP65 to IEC/EN 60529

Electrical data

Design of control element	Normally open contact (NO), Opener (NC)
Switching principle	Snap switch element
Number of shutters	1
Number of openers	1
Rated impulse withstand voltage	4
Rated insulation voltage	250
Thermal test current	16 A
Utilisation category	AC-15: 230 V / 4 A
Max. fuse rating	16 A gG D-fuse

Dimensions

Dimensions of the sensor	
- Width of sensor	106
- Height of sensor	99
- Length of sensor	63
Dimensions of the lever	
- Width of the lever	25
- Height of the lever	141
- Length of the lever	25
Roller diameter	25

Switch travel diagram

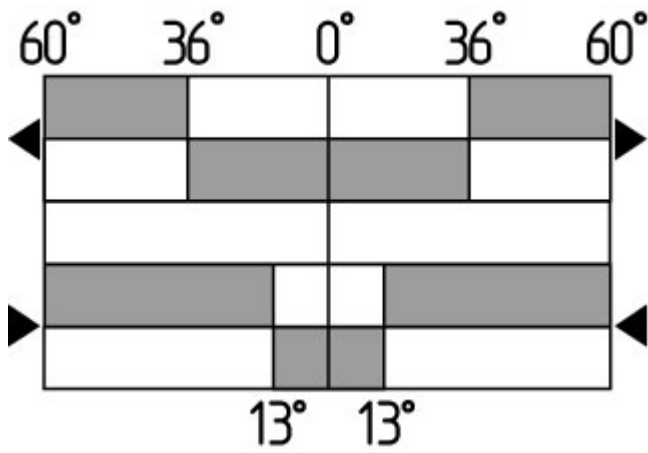

Notes Switch travel diagram

■ Contact closed

□ Contact open

▨ Setting range

Ⓛ Break point

Ⓟ Positive opening sequence/- angle

VS adjustable range of NO contact

VÖ adjustable range of NC contact

N after travel

Documents

Declaration of conformity (de) 94 kB, 08.08.2016

Code: __422p01

Declaration of conformity (pl) 129 kB, 08.08.2016

Code: __422p01_pl

Declaration of conformity (en) 84 kB, 29.11.2018

Code: __422p01_en

CCC certification (cn) 3 MB, 09.04.2018

Code: q_352p03

CCC certification (en) 3 MB, 09.04.2018

Code: q_352p02

Images



Product photo



Product photo

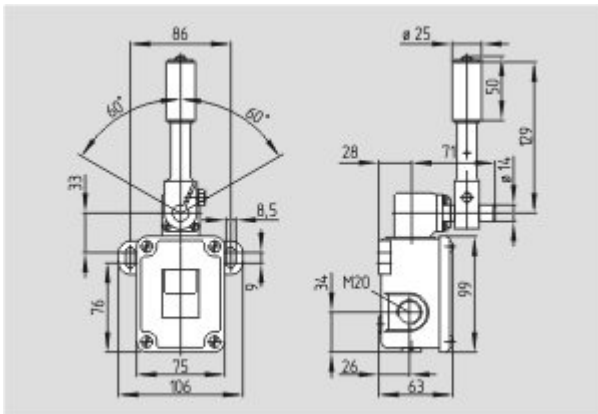

Dimensional drawing (basic component)

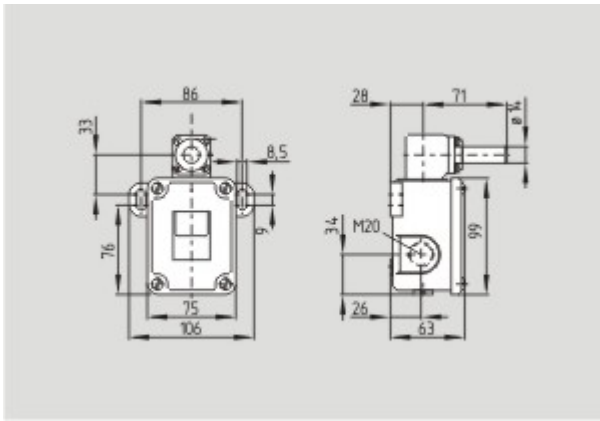

Dimensional drawing (basic component)

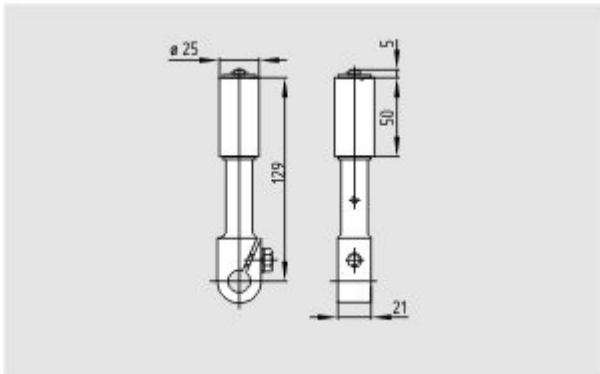

Dimensional drawing (miscellaneous)

K.A. Schmersal GmbH & Co. KG, Möddinghofe 30, D-42279 Wuppertal

The data and values have been checked thoroughly. Technical modifications and errors excepted.

Generiert am 13.02.2019 - 12:46:18h Kasbase 3.3.0.F.64I