

Datasheet - MP-AZ/AZM300-1

Solenoid interlock / AZM300 / Accessories AZM300

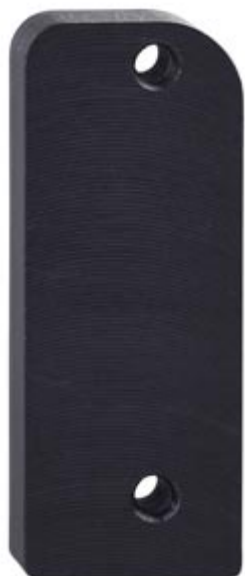

(Minor differences between the printed image and the original product may exist!)

Ordering details

Product type description	MP-AZ/AZM300-1
Article number	103003172
EAN Code	
eCl@ss	27-27-92-91

Global Properties

Permanent light	Montageplatte
Weight	250

Dimensions

Dimensions	
- Width	40
- Height	101
- Depth	18.5

Images

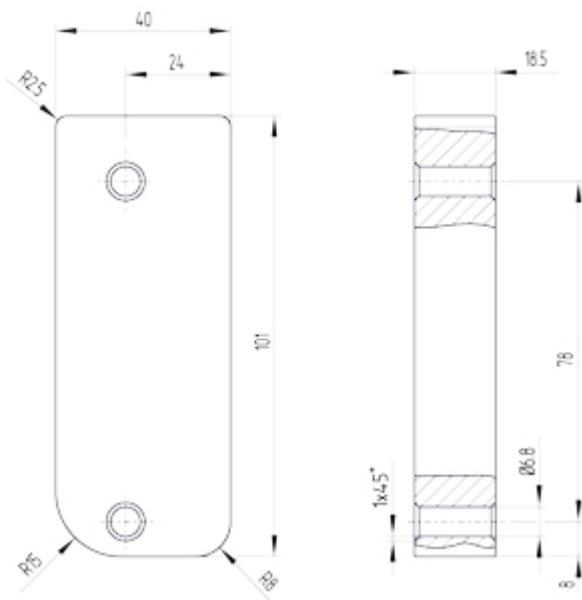

Dimensional drawing (miscellaneous)

K.A. Schmersal GmbH & Co. KG, Möddinghofe 30, D-42279 Wuppertal

The data and values have been checked thoroughly. Technical modifications and errors excepted.

Generiert am 13.02.2019 - 14:50:50h Kasbase 3.3.0.F.64I