

## Datasheet - AZM400Z-ST2-2P2P-E

Solenoid interlock / AZM400



(Minor differences between the printed image and the original product may exist!)

- Bistable, motor-driven system
- Clamping force 10.000
- Release possible against lateral forces up to 300 N
- PL e / cat. 4 / SIL 3 for interlocking and guard locking function
- Two-channel input signal of the guard locking function
- Operation on P/P- and P/N-switching outputs
- High tolerance to door misalignment
- Universal coding with RFID technology
- 2 Connector M12, 8- and 5-poles
- Guard locking monitored
- 2 Diagnostic outputs
- manual release
- Electric manual release with auxiliary voltage

### Ordering details

Product type description	AZM400Z-ST2-2P2P-E
Article number	103003588
EAN Code	4030661472638
eCl@ss	27-27-26-03

### Approval

Approval



### Classification

#### Interlocking function:

Standards	ISO 13849-1, IEC 61508
PL	up e
Control category	up 4
PFH value	$1.0 \times 10^{-9} / h$
PFD value	$9.0 \times 10^{-5}$
SIL	up 3
Mission time	20 Years

#### Guard locking function:

Standards	ISO 13849-1, IEC 61508
PL	up e
Control category	up 4
PFH value	$1.8 \times 10^{-9} / h$
PFD value	$1.6 \times 10^{-4}$
SIL	up 3
Mission time	20 Years

## Global Properties

---

Permanent light	AZM400
Standards	IEC 60947-5-1, ISO 14119, ISO 13849-1, IEC 61508
Compliance with the Directives (Y/N) 	Yes
Suitable for safety functions (Y/N)	Yes
Active principle	Magnetic field / RFID
Coding	Universal coding
Coding levels according to ISO 14119	low
Material of the housings	light alloy die-casting
Housing coating	None
Weight	730
Guard locking monitored (Y/N)	Yes
Idle assignable pushbutton and LED (Y/N)	No
Reaction time	≤ 100
Time to readiness	≤ 1.5 s
Recommended actuator	AZM400-B1

## Mechanical data

---

Design of electrical connection	2 Connector M12, 8- and 5-poles
Interlocking principle	bistable
Mechanical life	≥ 1.000.000 operations
- which have a lateral force $F_{\text{quer}} = 100$	100.000 operations
Switch distance	
- Allowable distance actuator / device incl. angular misalignment	1 ... 7
- Minimum distance devices	30
restistance to shock	30 / 11
Resistance to vibration	10 ... 150 HZ, Amplitude 0,35 mm
Emergency unlocking device (Y/N)	No
Manual release (Y/N)	Yes
Electronic manual release available (Y/N)	Yes
Clamping force	10.000
Max. lateral force at bolt return (against locked door)	300
- Notice: does not apply to emergency exit, Bowden cable and manual release	
fixing screws	2 x M6 (10.9)
Tightening torque for fixing screws	8
Actuator and interlock misalignment	2
With securing holes for Bowden cable assembly (Y/N)	No
Tightening torque of the fixing screws Bowden cable	No information

## Ambient conditions

---

Ambient temperature	
- Min. environmental temperature	0
- Max. environmental temperature	+55
Storage and transport temperature	
- Min. Storage and transport temperature	-40
- Max. Storage and transport temperature	+85
Protection class	IP66, IP67 to IEC/EN 60529
Protection rating	III
Air clearances and creepage distances To IEC/EN 60664-1	
- Rated impulse withstand voltage	0,8
- Overvoltage category	III

- Degree of pollution 3

## Electrical data

---

Number of auxiliary contacts	0
Number of safety contacts	2
Cross circuit/short circuit recognition possible (Y/N)	Yes
Supply voltage (stabilised PELV)	24 -15 / +10
Switch frequency	0,3
Operating current	0,1 A
- During the displacement of the bolt	0,6 A
Rated insulation voltage	32 VDC
Required rated short-circuit current	100 A
Device insulation	2 A
Auxiliary voltage (uninterruptible power supply)	24 -15 / +10
Min. open / close cycle (Motor)	3
- with continuous operation min. average cycle time	20

## Electrical data - Safety outputs

---

Safety outputs	Y1 and Y2
Design of control output	short-circuit proof, p-type
Rated operating voltage	24
Residual current	≤ 0,5
Operating current	0,25 A
Utilisation category	DC-12, DC-13
Test impulse width	≤ 0,4
Voltage drop	≤ 2
Test frequency	1

## Electrical data - Diagnostic output

---

Serial diagnostics (Y/N)	No
Design of control output	short-circuit proof, p-type
Number of diagnostic signals	2
Rated operating voltage	24
Operating current	0,05 A
Voltage drop	≤ 2
Utilisation category	DC-12, DC-13
Operating principle of the diagnostic output	The short-circuit-proof diagnostic outputs OUT1 and OUT2 can be used for central displaying or control tasks, e.g. in a PLC.
notice	The diagnostic output are not safety relevant outputs!

## Electrical data - Control inputs

---

Control inputs to unlock	E1 and E2, p-type; E3, n-type
Switching thresholds	-3 ... 5 (Low) 15 ... 30 (High)
Operating current per input	> 10 ... < 15 / 24
Permissible residual drive current	1.5
Allowable discrepancy time input	≤ 10
Acceptable test impulse on the input signal	< 5
- with a test impulse distance of	≥ 40

## LED switching conditions display

---

LED switching conditions display (Y/N)	Yes
LED switching conditions display	
- Supply voltage	green LED
- switching condition	yellow LED
- Error functional defect	red LED

## ATEX

---

Explosion protection categories for gases	None
Explosion protected category for dusts	None

## Dimensions

---

Dimensions of the sensor	
- Width of sensor	77.8
- Height of sensor	166.7
- Length of sensor	46.7

## Pin assignment

---

1	OUT2 Diagnostic output 2
2	E1 Control input 1
3	- (not used)
4	Y1 Safety output 1
5	OUT1 Diagnostic output 1
6	E3 Control input 3
7	Y2 Safety output 2
8	E2 Control input 2
1 (ST2)	A1 Supply voltage $U_B$
2 (ST2)	H2 GND
3 (ST2)	A2 GND
4 (ST2)	H1 Auxiliary voltage $U_{he}$
5 (ST2)	FE Functional earth connection

## Included in delivery

---

Actuators must be ordered separately.

## Ordering code

---

AZM400Z(1)(2)(3)(4)(5)

(1)	
ST	1 connector plug M12, 8-pole
ST2	2 connector plug M12, 8-pole / 5-pole
(2)	
<i>without</i>	Included in standard version Coding
I1	Individual coding
I2	Individual coding, multiple teaching
(3)	
1P2P	1 Diagnostic output and 2 Safety outputs, p-type (only for ST)
2P2P	2 and 2 Safety outputs, p-type (only for ST2)

(4)

*without*

**T**

BOW

Manual release

Emergency exit

(5)

*without*

**E**

without (only for ST)

(only for ST2)

## Documents

---

**Operating instructions and Declaration of conformity (it)** 1 MB, 26.10.2017

Code: mrl\_azm400\_it

**Operating instructions and Declaration of conformity (pl)** 1 MB, 18.01.2018

Code: mrl\_azm400\_pl

**Operating instructions and Declaration of conformity (pt)** 1 MB, 08.01.2018

Code: mrl\_azm400\_pt

**Operating instructions and Declaration of conformity (cn)** 1 MB, 22.11.2018

Code: mrl\_azm400\_cn

**Operating instructions and Declaration of conformity (de)** 1 MB, 07.09.2017

Code: mrl\_azm400\_de

**Operating instructions and Declaration of conformity (jp)** 1 MB, 30.06.2016

Code: mrl\_azm400\_jp

**Operating instructions and Declaration of conformity (en)** 1 MB, 07.09.2017

Code: mrl\_azm400\_en

**Operating instructions and Declaration of conformity (fr)** 1 MB, 19.09.2017

Code: mrl\_azm400\_fr

**Operating instructions and Declaration of conformity (nl)** 1 MB, 27.07.2018

Code: mrl\_azm400\_nl

**Operating instructions and Declaration of conformity (es)** 1 MB, 28.09.2017

Code: mrl\_azm400\_es

**Brochure (pl)** 705 kB, 01.02.2016

Code: b\_azm400p01\_pl

**Brochure (es)** 696 kB, 01.02.2016

Code: b\_azm400p01\_es

**Brochure (fr)** 688 kB, 01.02.2016

Code: b\_azm400p01\_fr

**Brochure (de)** 702 kB, 02.10.2015

Code: b\_azm400p01\_de\_rev2016

**Brochure (pt)** 824 kB, 02.02.2016

Code: b\_azm400p01\_pt

Brochure (en) 708 kB, 05.10.2015

Code: b\_azm400p01\_en\_rev2016

Brochure (it) 691 kB, 01.02.2016

Code: b\_azm400p01\_it

TÜV certification (de, en) 653 kB, 31.07.2017

Code: z\_azmp06

## Images

---

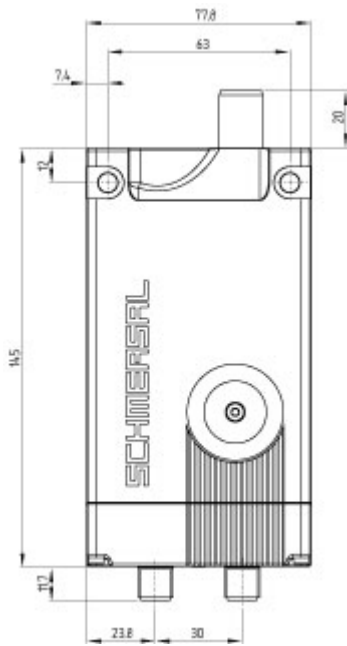

Dimensional drawing (basic component)

---

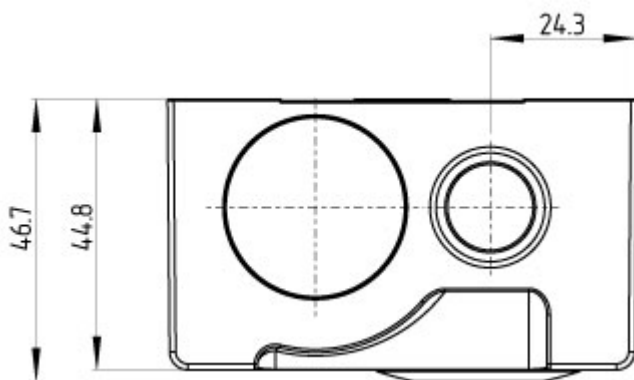

Dimensional drawing (basic component)

---

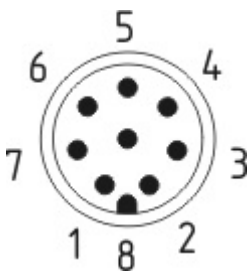

Contact arrangement

---

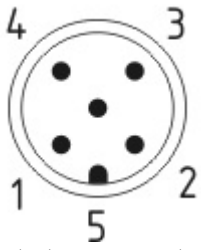

Contact arrangement

---

## System components

---

### Actuator



103003508 - AZM400-B1

---

K.A. Schmersal GmbH & Co. KG, Möddinghofe 30, D-42279 Wuppertal

The data and values have been checked thoroughly. Technical modifications and errors excepted.

Generiert am 13.02.2019 - 14:51:34h Kasbase 3.3.0.F.64I