

Cable-type displacement converter SWG series for use with absolute and incremental encoders

Document no.: SWG 11243 DE

Date: 04.02.2015



- **Very robust construction for mechanical engineering and industrial plant application**
- **For converting linear displacements of up to 40 m into a rotary movement**
- **For mounting onto an absolute or incremental encoder**
- **Easy to install and to use**
- **Protection grade IP 65 (IP 54)**

Functional description

The linear movement of a flexible steel cable, which can have a length of up to 40 m, is converted into a rotary movement with the aid of a measuring drum. The measuring drum is connected to the shaft of an encoder. In this way a change in displacement of the measuring cable causes the shaft of the encoder to rotate by a directly proportional amount which can be recorded.

The restoring force of the spring drive holds the measuring cable tight at all times and prevents any sagging which would otherwise induce an error. The measuring drum moves axially on a spindle ensuring that the cable is wound up precisely and reproducibly wrap for wrap in the helical groove of the drum.

The nozzle, through which the cable enters the drum, is protected with a brush and a bellows to prevent water or dust entering the drum. An additional grease chamber can be fitted upon request.

Cable-type displacement converter SWG

Technical data

- Measuring ranges: 15, 20, 25, 30, 35, 40 m
- Drum circumference: 490 mm nom.
- Permissible cable speed: ref. to table page 4
- Permissible cable acceleration: ref. to table page 4
- Force required to draw out the cable (start / end): 15 N max. / 30 N max.
- Cable material and diameters: highly flexible, stranded wire,
(Stainless steel 1.4401) 1.3 mm (for 15 to 25 m),
0.80 (for 30 to 40 m)
- Life expectancy for cable and spring: $\geq 10^6$ cable strokes
- Housing material: anodized aluminium
- Spring housing: plastic
- Working and storage temperature range: -20 °C to +70 °C
-30 °C (optional)
- Protection grades: Housing IP 65
Cable entry IP 54
- Mass: ref. to table page 4

Cable-type displacement converter SWG

Order code format

SWG	20	B	FK	01
------------	-----------	----------	-----------	-----------

01 Basic version for model no. 58*
 03 Basic version for model no. 65
 08 Basic version for model no. 50

FK Grease chamber (optional)

Accessories (optional):

B with bellows (standard)
 U with deflection roller

Measuring ranges:

15 15 m
 20 20 m
 25 25 m
 30 30 m
 35 35 m
 40 40 m

SWG Cable-type displacement converter

* Variations from the basic version are indicated with a succeeding, additional number and are documented in our works.

Encoders in connection with cable-type converters

Generally encoders and converters are supplied as one unit. Upon request both items are also available as separate units.

The following TWK-series of digital, incremental and analogue encoders with 58 mm dia synchro flanges can be mounted onto SWG-converters: C series, K series and T series. Technical descriptions of such encoders are available as individual data sheets.

The following accessories can be supplied:

- Deflection roller SWF-U for cable (90°).
- Prolongator SWF-VX for cable.
- Protective bellow SWF-BALG for cable entry.
- External brush case SWF-BÜVO to avoid entry of dust.

For use under aggressive ambient conditions, e.g. in maritime climate, the convertes can be supplied with a protective anodised hard coating.

Adapter rings for encoders with the following mounting flanges: 50, 58, 65, 66, 90 and 105 / GIM 900.

Cable-type displacement converter SWG

Drawing

Dimensions in mm

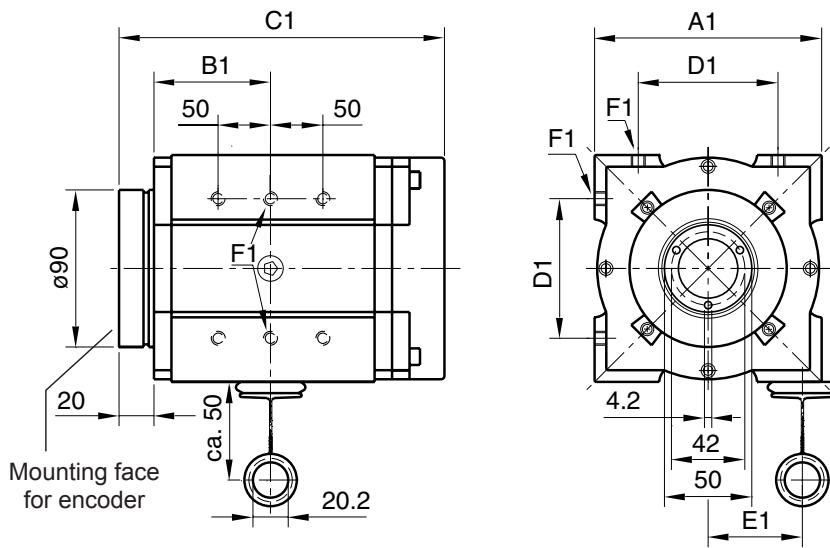

Models	15 m	20 m	25 m	30 m	35 m	40 m
A1	190	190	190	190	190	190
B1	66,7	81,9	97,2	112,5	127,7	143
C1	186,3	216,7	274,3	304,9	335,3	365,9
D1	140	140	140	140	140	140
E1	79	79	79	79	79	79
F1	6 x M10; 10 deep					
Mass (kg)	7.5	12.8	14	15.5	16	19.3
V_{max}^*	12 m/s	10 m/s	8 m/s	6 m/s	4 m/s	2 m/s
a_{max}^*	20 m/s ²	16 m/s ²	12 m/s ²	8 m/s ²	6 m/s ²	4 m/s ²

* At 20 °C working temperature.

Mounting position

The F1 threaded holes at two faces permit to adjust the position of the cable exit to suit the requirements in situ.

Note: The cable exit should be downwards or sideways. The cable must be extracted rectilinearly with reference to the housing (no lateral deflection admitted).

Cable nozzle

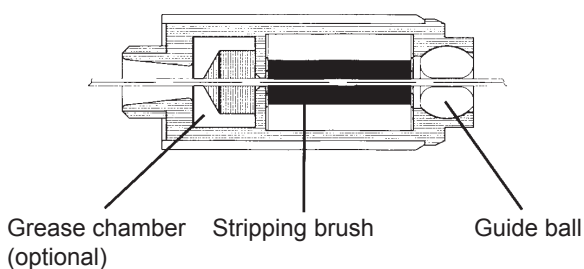

Cable-type displacement converter SWG

Structure principle

