

**Play-free electronic digital switching cam encoder
with electromagnetic absolute encoder / CANopen
Model NOCN**

Document No.: NOC 12523 LE
Date: 09.11.2018

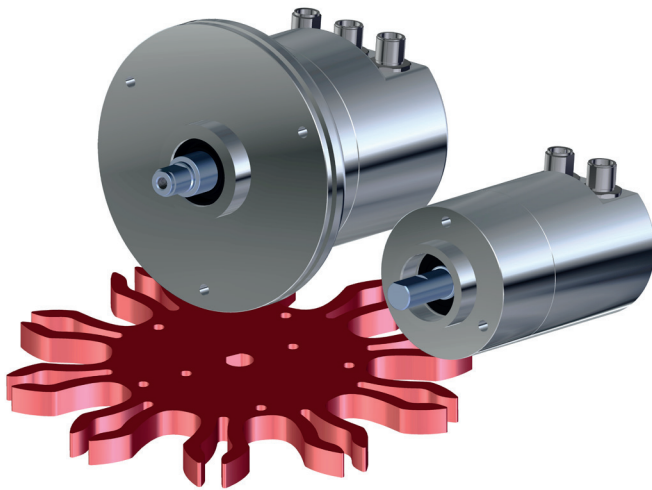

- **Play-free version for use instead of electromechanical switching cam encoders**
- **For use in stationary and mobile machines and systems, particularly for wind turbines, power plants, cranes, etc.**
- **Up to six electronically controlled switching outputs consisting of**
 - **Relay: Changeover contacts**
 - **PhotoMOS: Normally open/closed contacts**
- **Integrated absolute multiturn encoder with CANopen interface**
- **Parameterisable via CANopen bus**
- **High vibration and shock resistance thanks to the robust design**
- **Option: ♦ SIL2 certificate (Datasheet [NOC13099](#))**
 - ♦ **Velocity signal via CANopen**
- **Further available versions:**
 - ♦ **CANopen safety: Datasheet [NOC13099](#)**
 - ♦ **SSI: Datasheet [NOC12555](#)**
 - ♦ **SSI - SIL2: Datasheet [NOC 14199](#)**
 - ♦ **Analog: Datasheet [NOC12393](#)**

Contents

Design 1

Description..... 2

Principle circuit diagram 2

Technical data..... 3

 Electrical data 3

 Mechanical data..... 3

 Environmental data 4

 Switching output relay electrical data 4

 PhotoMOS output electrical data 4

Order code number 5

Interface CANopen..... 6

 CANopen specifications..... 6

 CANopen data profile..... 6

Switching outputs 7

 Function 7

 Cam diagram 7

 Parameterisation of the switching outputs (cams) 8

 Example 1 for parameterisation 9

 Example 2 for parameterisation 10

Versions of galvanic separation..... 11

Connectors - contact numbering 12

Installation drawings 13

Accessories 19

Play-compensating toothed gear ZRS..... 20

Programming example for CANopen output and relays / cams 21

Table for factory programming according to customer specifications..... 22

Design

- Robust housing manufactured from seawater-proof aluminium (AlMgSi1) or stainless steel (material: 1.4305 optionally 1.4404).
- Shaft fitted with ball bearings bears the magnet for recording the angular position and the drive gear of the multiturn transmission for absolute revolution counting.
- Shaft and transmission are located in the prechamber. Sealed off from this, the main chamber contains all electronic components for position recording, evaluation and output.
- Available Versions:
 - Ø 58 mm with different flange and shaft designs. 2 x relay and 2 x PhotoMOS at maximum.
 - Ø 64 mm (standard) with clamping collar and M6 threaded holes plus two device connectors. 2 x relay and 2 x PhotoMOS at maximum.
 - Ø 120 mm (optional) with clamping collar, M6 threaded holes and synchroniser groove. 4 relays at maximum.
 - Ø 79 mm with short housing length.
 - 4 x relay
 - 4 x relay and 2 x PhotoMOS (on request)
- Electrical connection for voltage supply, switching outputs and CANopen data via M12 connectors or cables. The number of connectors or cables varies depending on version or customer specifications.

Electronic digital switching cam encoder model NOCN

Description

General functional principle

This involves a play-free electronic switching cam encoder (abbreviated to: NOCN) with a maximum of four galvanically separated switching outputs (cams), which can be set by the customer and which are activated or deactivated depending on the relevant position of the drive shaft. A parameterisable multiturn absolute encoder with CANopen interface plus the switching cam encoder printed circuit board with separate controller are integrated into the compact housing. The encoder's CANopen position signal and the switching outputs can be parameterised separately.

Parameterisation is carried out via the relevant CANopen objects in accordance with the encoder profile according to CiA, DS 406, revision 4.01.

The NOCN has a fault monitoring system which outputs a fault message via the CANopen bus (emergency message) on detection of a fault.

Absolute encoder

The absolute encoder is equipped with a CANopen interface. Its resolution is 12 bits (= 4096 steps) or 13 bits (= 8192 steps) per revolution. The measuring range set in the factory is 4096 revolutions. The absolute encoder's position data can be parameterised using CANopen objects.

16 or 256 revolutions are possible as the measuring range on request, as well as a velocity signal with adjustable gate time.

Switching outputs (cams)

The electronically activated cams can be used to control potential-free, galvanically separated switching processes. The switching outputs are implemented using mechanical relays with long service lives and using PhotoMOS semiconductors - as well galvanically separated. Model 120 contains four relays. Model 79 contains four relays and two PhotoMOS.

The switching information for the cams is taken from the absolute encoder. In comparison with an electromechanical switching cam encoder, switching output activation and deactivation is carried out electronically without play or wear.

Each of the cam relays has a changeover contact, which is routed out via an M12 connector. The PhotoMOS semiconductors provide normally open contacts (NO). Different connector assignments are possible on request by the customer.

The precise NOCN measuring range point at which each relay is to switch (switching flanks) can be set using the relevant CANopen objects.

Within the measuring range, one on and off process is possible per switching output. Customer-specific switching procedures are also possible ex-works.

If operating voltage is missing, the cams do not switch.

Principle circuit diagram

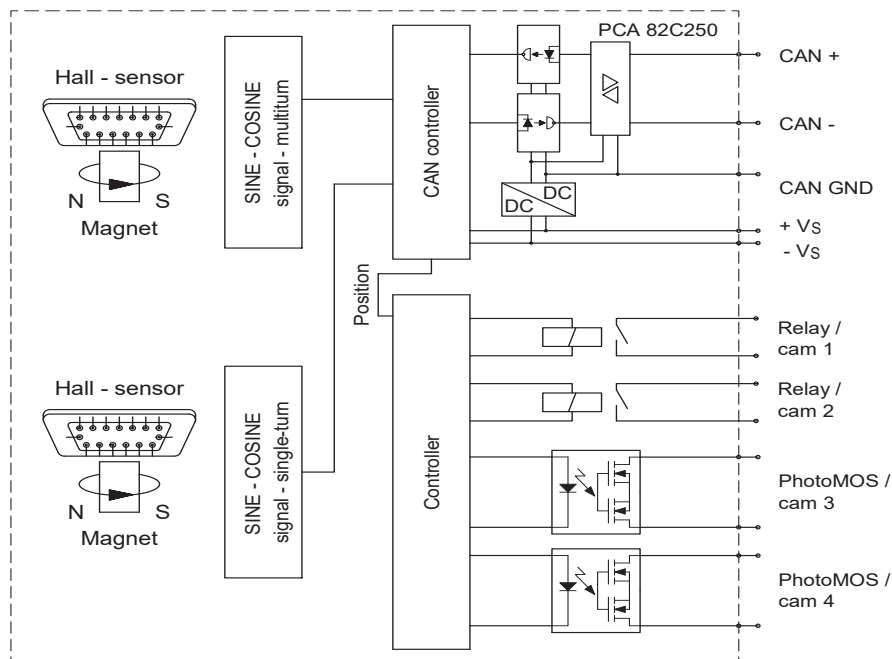

In case of model NOCN120 cam 3 and cam 4 are realized by relays as well. At model **NOCN79** four relays *and* 2 PhotoMOS can be realized simultaneously.

Electronic digital switching cam encoder model NOCN
Technical data
Electrical data

- Sensor system: ASIC with HALL elements
- Operating voltage range: + 11 VDC to + 28 VDC
- Power consumption: < 2.5 W
- Resolution: 4096 steps / 360° - (12-bit) or
8192 steps / 360° - (13-bit)
- Measuring range: 4096 revolutions, (option 16 or 256 revs.)
- Meas. step deviation: ± 0.5 LSB
- Absolute accuracy: ± 0.5 % / 360° (option: 0.25 %)
- Repeatability: ± 0.1 % / 360°
- Output code: Binary
- Code path: CW / CCW, parameterisable
- Temperature drift: ± 20 ppm / K typ.
- Reference value: 0 - (total No. of steps -1)
- Overvoltage protection and galvanic separation with CANopen bus
- CAN interface: According to ISO/DIS 11898
- Address setting: Via LMT / LSS
- Terminating resistor: To be implemented separately
- Max.transmission length: 200 m (also see CiA, DS 301)
- EMC standards:
 - Interference emission: acc. to EN 61000-6-4
 - Interference immunity: acc. to EN 61000-6-2
- Electrical connection: up to 3 x connector M12
Optional: cable
- CAN IC voltage rating: Maximum common mode voltage -7 to +12 V
Maximum allowed voltage at pins ± 36 V

Mechanical data

- Operating speed: 1000 rpm max.
- Angular acceleration: 105 rad/s² max.
- Moment of inertia (shaft): 20 gcm²
- Operating torque: ≤ 8 Ncm (at speed 500 rpm)
- Starting torque: ≤ 4 Ncm
- ZPerm. shaft load: 250 N axial
250 N radial
- Bearing service life: ≥ 10⁹ revolutions
- Weight: Approx. 0.8 kg (64 mm)
Approx. 1.4 kg (120 mm)

Electronic digital switching cam encoder model NOCN

Technical data

Environmental data

- Operating temperature range: - 40 °C to + 85 °C
- Storage temperature range: - 45 °C to + 85 °C
- Resistance:
 - To shock: 250 m/s², 6 ms,
(DIN EN 60068-2-27) 100 x each in 3 axes
 - To vibration: 100 m/s², 5 Hz ... 2000 Hz,
(DIN EN 60068-2-6) 1 h each in 3 axes (Higher values optional)
- Protection type: IP67, optionally IP69K
(DIN EN 60529)

Switching output relay electrical data

- Maximum switching current: 1.0 A at 30 VDC / VAC (0.5 A at 60 VDC / VAC)
- Maximum switching voltage: 60 VDC / VAC
 Note: The effective maximum voltage is dependent on the connector into which the switching contacts are integrated:
 M12, 12-pin: max. 30 VDC, M12, 8-pin: max. 60 VDC.
- Response time: 3 ms (ON and OFF)
- Resistance ON: < 0.5 Ohms
- Relay life time: > 5 x 10⁵ operations
- Switching hysteresis: 10 digits (~1°)
Parameterisable

PhotoMOS output electrical data (@ 25 °C)

- Maximum load current: 0.5 A (continuous) / 1.5 A (peak)
- Maximum load voltage: 60 VDC / VAC
 Note: The effective maximum voltage is dependent on the connector into which the switching contacts are integrated:
 M12, 12-pin: max. 30 VDC, M12, 8-pin: max. 60 VDC.
- Maximum power dissipation: 300 mW
- On resistance: 0.83 Ω typ.
- Maximum OFF state leakage current: 1 µA
- Turn ON / OFF time
(90 % of final value):
 ON: 0.65 ms typ. / 2 ms max.
 OFF: 0.04 ms typ. / 0.2 ms max.
- I/O capacitance: 1.5 pF max.
- Switching hysteresis: 10 digits (~1°)

Fault monitoring and status

If the internal fault monitoring system detects a malfunction in one of the monitored functions in the electronic switching cam encoder, a fault which can be processed by the control system is output via the CANopen bus.

Electronic digital switching cam encoder model NOCN

Order code number

NOCN	64	-	K	A	4	-	4096	R	4096	C2	S2	V1	N	01	→ Standard version
<p>Electrical and mechanical variants *</p> <p>01 Standard</p> <p>Interface:</p> <p>N CANopen</p> <p>Galvanic separation †. See page 6:</p> <p>V1 $-V_s \neq \text{CAN_GND} \neq$ screening/housing → Recommended</p> <p>V2 $-V_s = \text{CAN_GND} \neq$ screening/housing</p> <p>V3 $-V_s = \text{CAN_GND} =$ screening/housing</p> <p>Electrical connections (see remark on page 11, 12):</p> <p>→ Combine kind (S, T, K, L) and number of desired connection</p> <p>1 = 1 connection</p> <p>2 = 2 connections</p> <p>3 = 3 connections</p> <p>S Via device connector M12, radial</p> <p>T Via device connector M12, axial (at NOCN79 only on request)</p> <p>K Via cable, 1 m **, radial ** other lengths possible</p> <p>L Via cable, 1 m **, axial (at NOCN79 only on request)</p> <p>Profile:</p> <p>C2 CANopen acc. to CiA, DS 406 revision 4.01</p> <p>Measuring ranges:</p> <p>16</p> <p>256 Revolutions</p> <p>4096</p> <p>Code:</p> <p>R Binary</p> <p>Resolution in steps / 360°:</p> <p>4096 = 12 Bits, 13 Bit = 8192 at maximum</p> <p>Number of switching outputs:</p> <p>2 2, 4 at maximum, 6 at max. at NOCN 79 (Relays and/or PhotoMOS)</p> <p>Housing material:</p> <p>A Aluminium</p> <p>S Stainless steel 1.4305</p> <p>V Stainless steel 1.4404</p> <p>Flange and shaft:</p> <p>58 K Clamped flange Shaft 10 mm with flat</p> <p>KP Clamped flange Shaft 10 mm with parallel key</p> <p>KZ Clamped flange Shaft 12 mm for play-compensating toothed gear ZRS</p> <p>SN Synchro flange Clamping shaft 12 mm with notch</p> <p>SR Synchro flange Clamping shaft 12 mm</p> <p>ST Synchro flange Shaft 6 mm with flat</p> <p>64 K Clamped flange Shaft 12 mm with flat</p> <p>KP Clamped flange Shaft 12 mm with parallel key</p> <p>KZ Clamped flange Shaft 12 mm for play-compensating toothed gear ZRS</p> <p>KN Clamped flange Clamping shaft 12 mm with notch</p> <p>KR Clamped flange Clamping shaft 12 mm</p> <p>65 S Synchro flange Shaft 12 mm</p> <p>SP Synchro flange Shaft 12 mm with parallel key</p> <p>66 K Clamped flange Shaft 10 mm with flat</p> <p>KP Clamped flange Shaft 10 mm with parallel key</p> <p>79 KZ Clamped flange Shaft 12 mm for play-compensating toothed gear ZRS (standard)</p> <p>120 M Assembly flange Shaft 12 mm with flat</p> <p>Design form:</p> <p>Flange: \varnothing in mm</p>															

NOCN Electronic digital switching cam encoder with CANopen interface

* : The basic versions according to the data sheet bear the number 01. Deviations are identified with a variant number and are documented in the factory.
 Definition of the standard: PDO with velocity signal, 4 normally open (NO) contacts

Electronic digital switching cam encoder model NOCN

Order code number, remarks Find details on page 11

- V1:** This version provides **complete galvanic separation**. Power supply and CAN_GND is galvanically separated. The housing and the screening of the cable is galvanically separated as well. The screening of the cable comes to the housing of the NOCN via the housing of the mating plug.
- V2:** This version provides **partly galvanic separation**. Power supply and CAN_GND are not galvanically separated. The housing and the screening of the cable are galvanically separated from power supply and CAN_GND. The screening of the cable comes to the housing of the NOCN via the housing of the mating plug and/or Pin of the connector. Please note the maximum voltage rating of the CAN interface IC on [side 3](#).
- V3:** This version provides **no galvanic separation**. Power supply and CAN_GND are not galvanically separated. The housing and the screening of the cable are not galvanically separated from power supply and CAN_GND. The screening of the cable comes to the housing of the NOCN via the housing of the mating plug and/or Pin of the connector. Please note the maximum voltage rating of the CAN interface IC on [side 3](#).

Order code number, mating plugs

EMC-resistant, metal version, straight
 M12, 4-pin: **STK4GS60** / M12, 5-pin: **STK5GS56** / M12, 8-pin: **STK8GS54** / M12, 12-pin: **STK12GS93**

Note: With connector M12, 12-pin, the recommended maximum voltage at the pins is 30 V.
 At higher voltages, we recommend M12 connectors with fewer pins.

Interface CANopen

Function

A CAN controller at the output enables integration into the CANopen network. According to "CANopen Application Layer and Communication Profile, CiA Draft Standard 301, Version 4.1" and according to "Device Profile for Encoders CiA Draft Standard Proposal 406 Version 4.01" and "CANopen Layer Setting Services and Protocol (LSS), CiA DSP 305".

Various parameters for the absolute encoder's position signal, which is output via the PDOs, can be parameterised via the bus in order to adapt the NOCN to the application. The details of the CANopen profile are exhaustively described in the NOC 12409 specifications.

The bootloader function can be used to update the NOCN's firmware at the customer's premises.

CANopen specifications

- NMT Master: no
- NMT-Slave: yes
- Maximum Boot up: no
- Minimum Boot up: yes
- COB ID Distribution: Default, SDO
- Node ID Distribution: via Index 2000 oder LSS
- No of PDOs: 2 Tx
- PDO-Modes: sync, async, cyclic, acyclic
- Variables PDO-Mapping: no
- Emergency Message: yes
- Heartbeat: yes
- No. of SDOs: 1 Rx / 1 Tx
- Device Profile: CiA DSP 406 Version 4.01

Bus activation according to ISO / DIS 11898

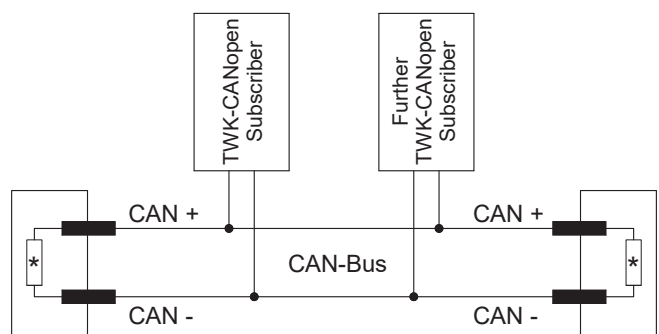

* Terminating resistor (120 Ω)

CANopen data profile: PDO

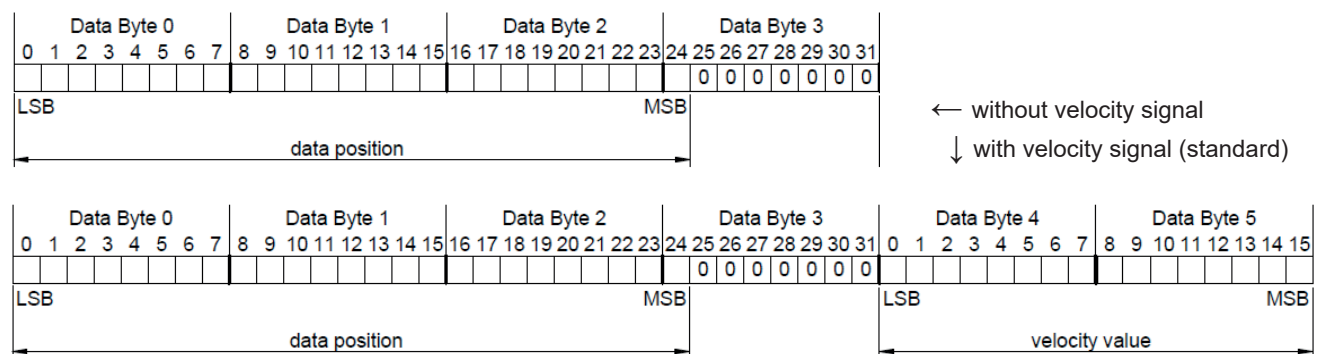

Note: It depends on resolution and measuring range how many bits are significant data bits for position (Here: 25 (bit 0 to 24) for 13 bits resolution and 12 bits measuring range). Velocity signal: signed 16 bits.

Electronic digital switching cam encoder model NOCN

Switching outputs

Function

The function of the switching outputs (cams) is implemented by means of relays and PhotoMOS semiconductors. The relays provide changeover contacts and the PhotoMOS semiconductors provide normally open contacts (NO).

All switching outputs are galvanically separated in terms of operating voltage and the CANopen bus.

The information regarding when which relay is to pick up and drop off again is made available to the relay control system by the internal controller. It receives the shaft position data from the NOCN's absolute encoder.

The precise position of the switching flanks, i.e. calibration of the cams, can be carried out via the corresponding objects of the encoder profile according to CiA, DS 406, rev. 4.01 (see [pages 8 - 10](#)).

The switching flanks of the switching outputs are set as follows in the factory as regards the angular position of the shaft (see cam diagram below for a NOCN with a measuring range of 16 revolutions):

The cams are picked-up/switched over 1 revolution (status '1') and are not picked-up/switched over the remainder of the

measuring range (status '0'). The default switching length L is therefore 1 revolution. All four cams each switch with an offset of 0.5 revolutions. Cam 1 switches on at revolution 0, cam 2 at revolution 0.5, cam 3 at revolution 1, etc. The switching flanks of the cams, with reference to the absolute encoder's position signal, accordingly lie at (steps / revs.): cam 1 low limit: 0 (0 revs.), cam 1 high limit: 4096 (1 rev.), cam 2 low limit: 2048 (0.5 revs.), cam 2 high limit: 6144 (1.5 revs.), cam 3 low limit: 4096 (1 revs.), cam 3 high limit: 8192 (2 revs.), etc.

The switching output switching flanks refer to the CANopen output signal of the absolute encoder. If the position signal's preset function is used (CANopen output signal offset), the switching flanks are also accordingly shifted with reference to the shaft position.

To avoid undesired switching back and forth (flutter) on the part of the relays when the shaft is stationary or as a result of slight shaft vibrations on the switching flank, a switching hysteresis of 10 digits ($\sim 1^\circ$) is pre-programmed. This can be changed via the CANopen bus.

Cam diagram

(Factory setting at device with 4 switching outputs. 6 at maximum at model 79)

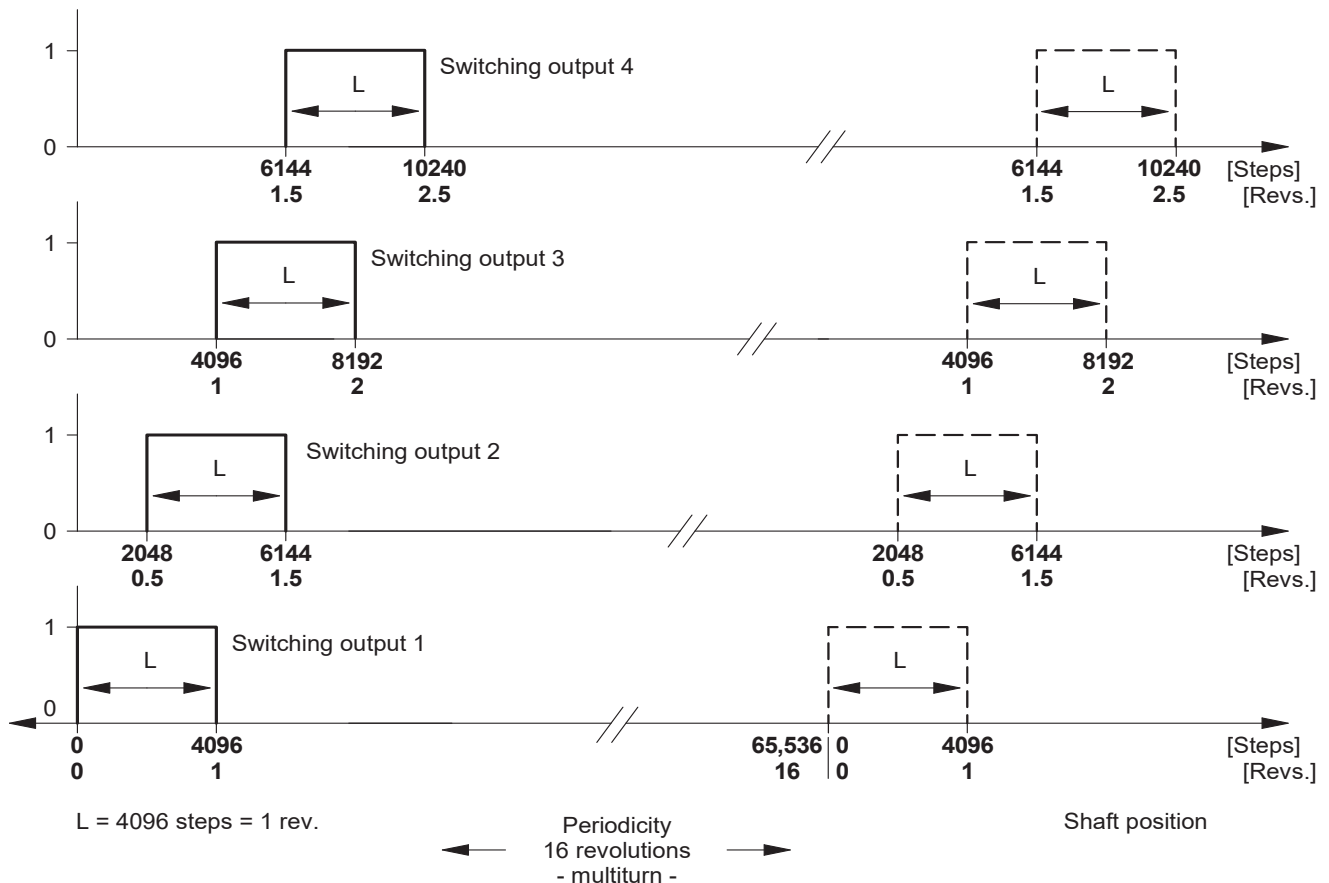

Electronic digital switching cam encoder model NOCN

Switching outputs

Parameterisation of the switching outputs (cams)

Each of the switching outputs can be parameterised via the CANopen bus. To achieve this, a range of objects is assigned to each switching output in the CANopen profile according to CiA, DS 406 revision 4.01. These objects enable each switching output to be set individually:

- Object 6310: Low limit Cam 1 > Cam 1 switches on in this position (relay picks up)
- Object 6320: High limit Cam 1 > Cam 1 switches off in this position (relay drops off)
- Object 6330: Hysteresis Cam 1 > Switching hysteresis of cam 1 in the case of the switching flanks (with low and high limit)
- Object 6311: Low limit Cam 2 > Cam 2 switches on in this position (relay picks up)
- Object 6321: High limit Cam 2 > Cam 2 switches off in this position (relay drops off)
- Object 6331: Hysteresis Cam 2 > Switching hysteresis of cam 2 in the case of the switching flanks (with low and high limit)

Correspondingly for objects 6312 - 6332 to objects 6315 - 6335 for cam 3 to cam 6.

Object 6300: Status of all cams (read only) > 0x0 = no cam picked up, 0x1 = only cam 1 picked up
0x2 = only cam 2 picked up, 0x3 = cams 1 and 2 picked up
Etc.

Object 6301: Enable register for all cams > 0x0 = no cam active, 0x1 = only cam 1 active
0x2 = only cam 2 active, 0x3 = cams 1 and 2 active
Etc.

Note: If the cams are disabled via object 6301, the momentary switching status (on or off) is retained and is no longer changed even on reaching a shaft angle range at which the cams ought to be switched off according to the programming.

Do not enable switching contacts which are not realized at your device (i.e. only 2 are realized). Otherwise an error message occurs.

If PhotoMOS contacts are realized, they always are called CAM5 and CAM6. Means when at NOCN64 all four contacts are realized they are called CAM1, CAM2, CAM5 and CAM6. Related CANopen objects have to be used.

At Model NOCN79: CAM1 to CAM6.

After switching the operating voltage off and on again, however, the relays are deactivated under all circumstances.

Object 6302h: Polarity of the cams (inversion option)

The reference variable for parameterisation is the position signal output by the absolute encoder. The measuring range ranges from step 0 to step 65,536 (in the version with 16 revs. - 4096 steps / 360° x 16). Each cam can be set within this range.

Electronic digital switching cam encoder model NOCN

Switching outputs

Example 1 for parameterisation

The switching cam encoder is intended to implement a limit switch function in both of the shaft's directions of rotation. The active measuring range should be 10 revolutions (40,960 steps). When the shaft rotates in the CCW direction, cam 1 should switch, i.e. the relevant relay should pick up. When the shaft rotates in the CW direction, cam 2 should switch after 10 revolutions. The relevant relays should therefore pick up adjacent to the active measuring range of 10 revolutions - relay 1 at the lower and relay 2 at the upper end.

If the cams are to switch on a peripheral device, the cams' relevant normally open contacts must be switched. The normally closed contacts can be used if a deactivation process is desired.

To avoid zero passage on the part of the absolute encoder's position signal, the active measuring range should commence at step 10,000 of the position signal. Step 50,960 is reached after 10 revolutions in the CW direction. As it may be the case that the switching cam encoder's shaft continues to be turned a few revolutions past the measuring range of 10 revolutions by the application (e.g. due to the inertia of a motor drive's mechanical system), cam 1 and cam 2 should remain picked up/switched precisely 1 revolution (4096 steps) past the measuring range boundaries. The switching length L should therefore be 1 revolution. To prevent the occurrence of switching flutter (switching back and forth) on the part of the cam relays in the case of the 4 switching flanks (cam 1 and cam 2 on and off 2 times each), a hysteresis of 55 steps (~5°) is set.

Relevant cam diagram

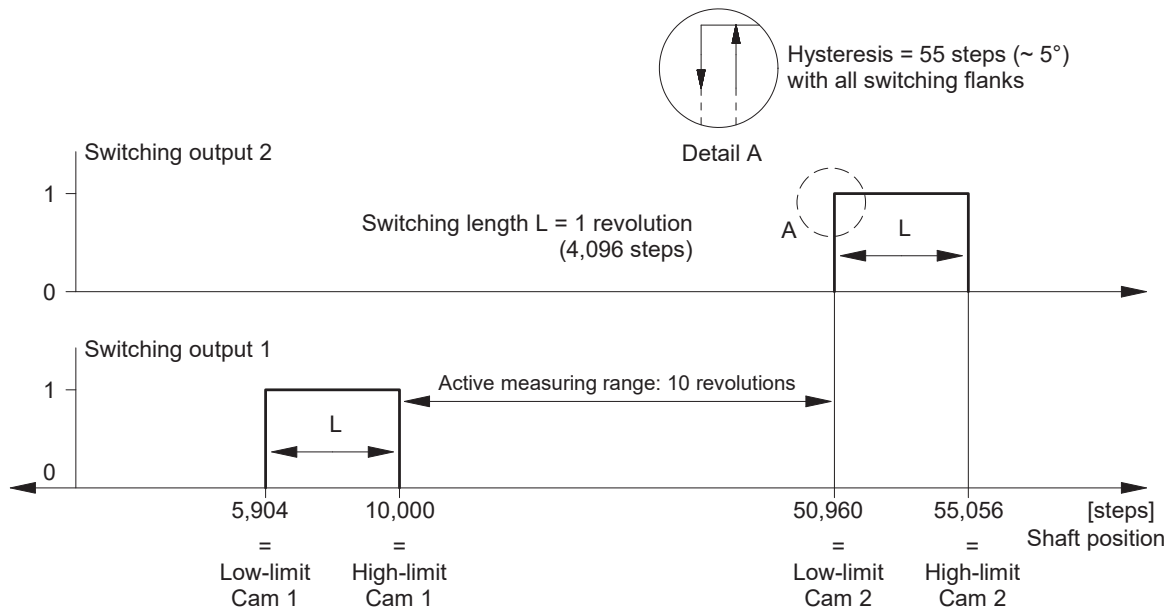

The following values must be input in this case:

Object 6310 = 5904dec, object 6320 = 10,000dec, object 6330 = 55dec, object 6311 = 50,960dec
 Object 6321 = 55,056dec, object 6231 = 55dec, object 6301 = cam enable register.

So that switching outputs 1 and 2 (cams 1 and 2) fulfil their switching activity, they must be enabled via object 6301 (see [page 8](#)). Minimal rotation of the shaft at the corresponding points at which the switching flanks have been set up can be used to check the switching activity of the relays or the cams e.g. by connecting an LED, etc.

It is also possible to have the cams switch in inverted form, i.e. the relays are dropped off rather than picked up for 1 revolution at the points shown above. I.e. they are picked up/switched for 15 revolutions. To achieve this, the cams can be inverted via object 6302.

The switching behaviour is repeated by turning 16 revolutions further.

Electronic digital switching cam encoder model NOCN

Switching outputs

Example 2 for parameterisation

Both cams should be switched (normally open contacts closed) within the measuring range of 10 revolutions (active measuring range). If the lower limit of the measuring range is reached, cam 1 switches off (normally open contact opens). If the upper limit is reached (revolution 10), cam 2 switches off. At this point, cam 1 should remain switched for a further

revolution in order to obtain clear switching relationships at the upper limit of the measuring range. This also applies accordingly to cam 2 at the lower limit of the measuring range. The switching length L in the case of both cams is 11 revolutions (45,056 steps). The active measuring range should commence again at step 10,000.

The following values must be input:

Object 6310 = 10,000dec, object 6320 = 55,056dec, object 6330 = 55dec, object 6311 = 5904dec
 Object 6321 = 50,960dec, object 6231 = 55dec, object 6301 = cam enable register.

Relevant cam diagram

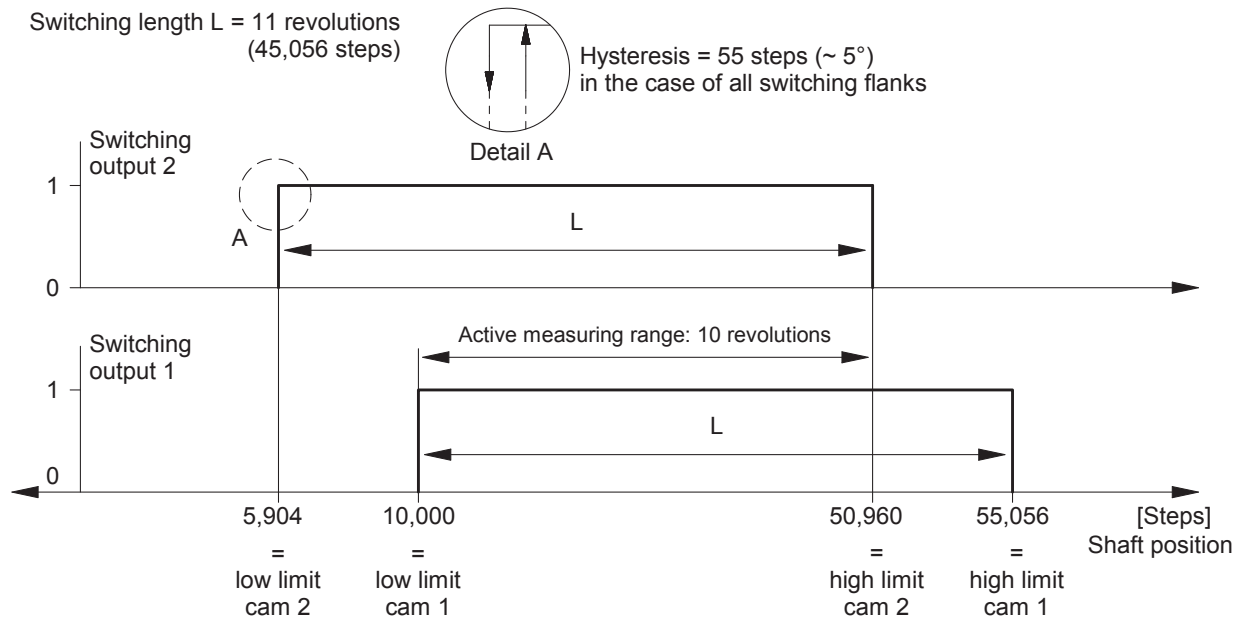

Electronic digital switching cam encoder model NOCN

Connector assignment and versions of galvanic separation

Example is valid for standard version

Attention: The description of the different versions of galvanic separation, V1 to V3, refers only to the relationships of the individual potentials (-UB, CAN_GND and housing/shield) to one another. I.e. whether they are galvanically connected or not. The connection plug pin assignments shown below are independent of this and only describe the standard pin assignment. Other variants may reveal a different pin assignment. The connection assignment (TYxxxx) which is enclosed with each device or can be requested must always be observed.

Note: The recommended version is V1 with full galvanic separation. This offers maximum EMC resistance, maximum CANopen data transfer security and thus maximum operating safety.

Versions V2 and V3 are special versions which must be compatible with the structure (topology) of the CANopen bus system in the customer application (→ control system and other CANopen subscribers). Operating safety or data transfer security may otherwise be affected.

Version 1 (V1): CAN_GND and U_B galvanically separated (≠). Screening galvanically separated (≠)

This recommended version provides complete galvanic separation. Power supply and CAN_GND is galvanically separated. The housing and the screening of the cable is galvanically separated as well. The screening of the cable comes to the housing of the NOCN via the housing of the mating plug.

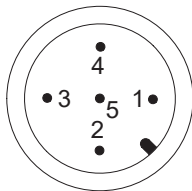

female

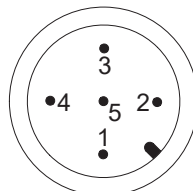

male

PIN	Function for standard version
1	CAN GND
2	Operating voltage + U _B
3	Operating voltage - U _B
4	CAN_H
5	CAN_L

Version 2 (V2): CAN_GND and U_B not galvanically separated (=). Screening galvanically separated (≠)

This version provides partly galvanic separation. Power supply and CAN_GND are not galvanically separated. The housing and the screening of the cable are galvanically separated from power supply and CAN_GND. The screening of the cable comes to the housing of the NOCN via the housing of the mating plug and/or Pin 1 of the connector. Please note the maximum voltage rating of the CAN interface IC on [page 3](#).

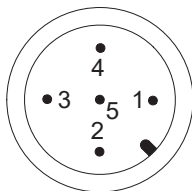

female

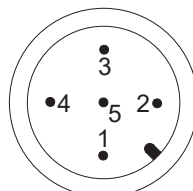

male

PIN	Function for standard version
1	Screen (Cable / housing)
2	Operating voltage + U _B
3	Operating voltage - U _B and CAN_GND
4	CAN_H
5	CAN_L

Version 3 (V3): CANGND and U_B not galvanically separated (=). Screening not galvanically separated (=)

This version provides no galvanic separation. Power supply and CAN_GND are not galvanically separated. The housing and the screening of the cable are not galvanically separated from power supply and CAN_GND. The screening of the cable comes to the housing of the NOCN via the housing of the mating plug and/or Pin 1 of the connector. Please note the maximum voltage rating of the CAN interface IC on [page 3](#).

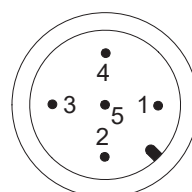

female

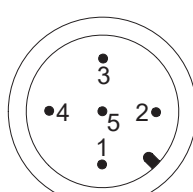

male

PIN	Function for standard version
1	Screen (Cable / housing) - shorted to pin 3 -
2	Operating voltage + U _B
3	Operating voltage - U _B and CAN_GND - shorted to pin 1 -
4	CAN_H
5	CAN_L

Electronic digital switching cam encoder model NOCN

Connectors - contact numbering

Selection

Contact arrangement and numbering

Viewed looking at the PIN side of the connector installed in the NOCN.
 Different M12 connector combinations or assignments are possible at the request of the customer.
 Please observe connection assignment TY enclosed with each device.

Connector, 4 pin

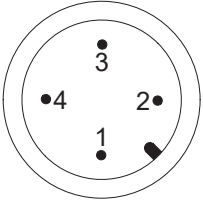

Connector, 5 pin

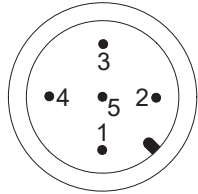

Connector, 8 pin

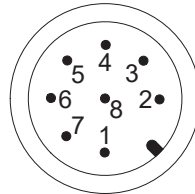

Connector, 12 pin

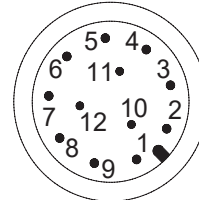

With M12, 12-pin, the recommended maximum voltage at the individual pins is 30 V.

Example for connector with 4 switching contacts

Model 64 with 2 relays and 2 PhotoMOS or model 79 with 4 relays - normally open contacts are shown.
 Normally closed contacts or change over contacts are possible when using relays.

PIN	Function at standard
1	Contact 1 / (13)
2	Contact 1 / (14)
3	Contact 2 / (23)
4	Contact 2 / (24)
5	Contact 3 / (33)
6	Contact 3 / (34)
7	Contact 4 / (43)
8	Contact 4 / (44)

Example for connector with 6 switching contacts

Model 79 with 4 relays und 2 PhotoMOS - normally open contacts are shown.
 Normally closed contacts or change over contacts are possible when using relays.

PIN	Function at standard
1	Contact 1 / (13)
2	Contact 1 / (14)
3	Contact 2 / (23)
4	Contact 2 / (24)
5	Contact 3 / (33)
6	Contact 3 / (34)
7	Contact 4 / (43)
8	Contact 4 / (44)
9	Contact 5 / (53)
10	Contact 5 / (54)
11	Contact 6 / (63)
12	Contact 6 / (64)

Electronic digital switching cam encoder model NOCN

Anschlusstecker - Pinnummerierung

Example for connector with 2 switching contacts

Model 64 with 2 relays - Change over contacts are shown

PIN	Funktion bei Standardbelegung
1	Contact 1 / (12) - Normally closed contact
2	Contact 1 / (11) - common contact
3	Contact 1 / (14) - Normally open contact
4	Contact 2 / (22) - Normally closed contact
5	Contact 2 / (21) - common contact
6	Contact 2 / (24) - Normally open contact
7	not connected
8	not connected

Contact 7 and 8 can be used for an additional PhotoMOS contact.

Installation drawings

Selection, further drawings on request

Model NOCN58-KP (2 connectors)

Dimensions in mm

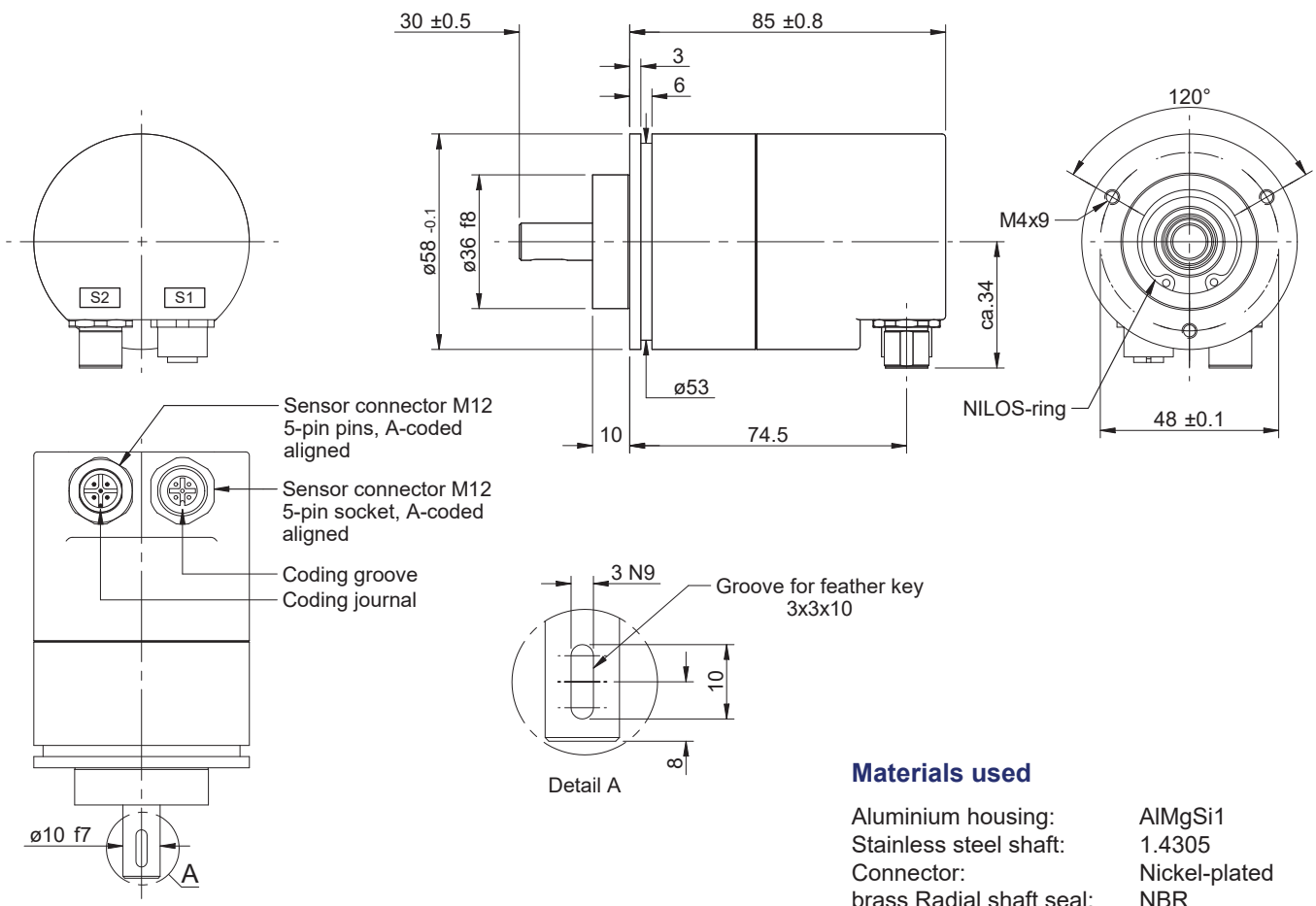

Materials used

Aluminium housing:	AlMgSi1
Stainless steel shaft:	1.4305
Connector:	Nickel-plated
brass Radial shaft seal:	NBR
Sealing rings:	NBR

Electronic digital switching cam encoder model NOCN

Installation drawings

(Selection, further drawings on request)

Modell NOCN58-ST (2 connectors)

Dimensions in mm

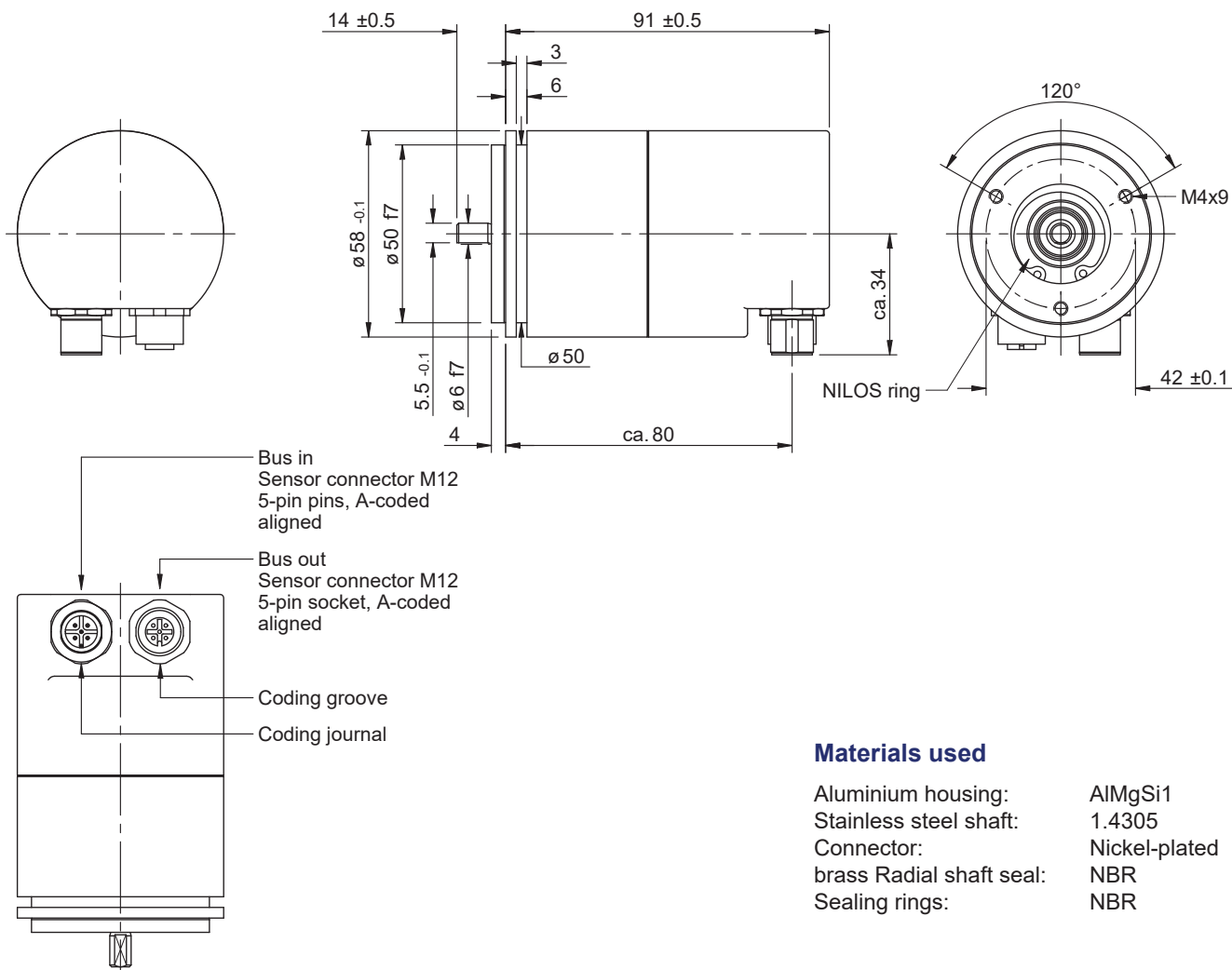

Materials used

Aluminium housing:	AlMgSi1
Stainless steel shaft:	1.4305
Connector:	Nickel-plated
brass Radial shaft seal:	NBR
Sealing rings:	NBR

Electronic digital switching cam encoder model NOCN

Installation drawings

(Selection, further drawings on request)

Modell NOCN58-K (2 connectors axial)

Dimensions in mm

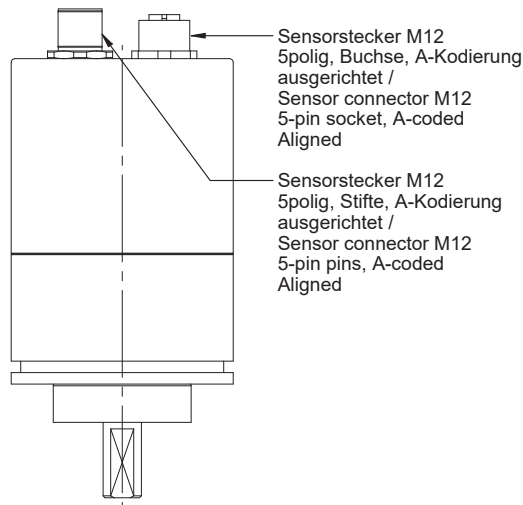
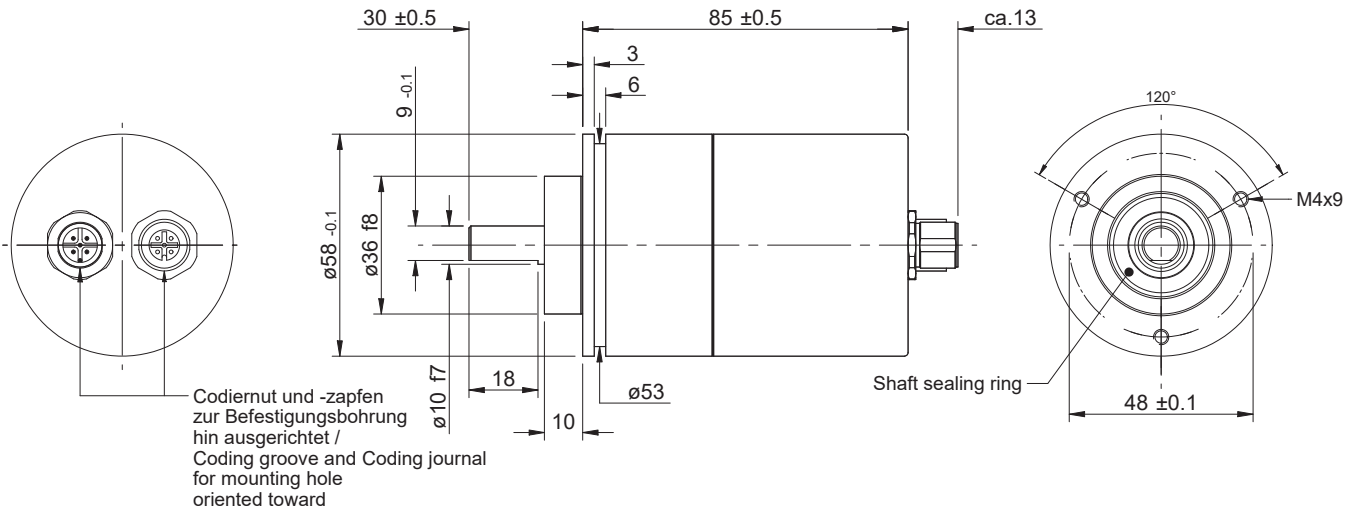

Materials used

Aluminium housing:	AlMgSi1
Stainless steel shaft:	1.4305
Connector:	Nickel-plated
Brass radial shaft seal:	NBR
Sealing rings:	NBR

Electronic digital switching cam encoder model NOCN

Installation drawings

(Selection, further drawings on request)

Model NOCN64-K (2 connectors)

Dimensions in mm

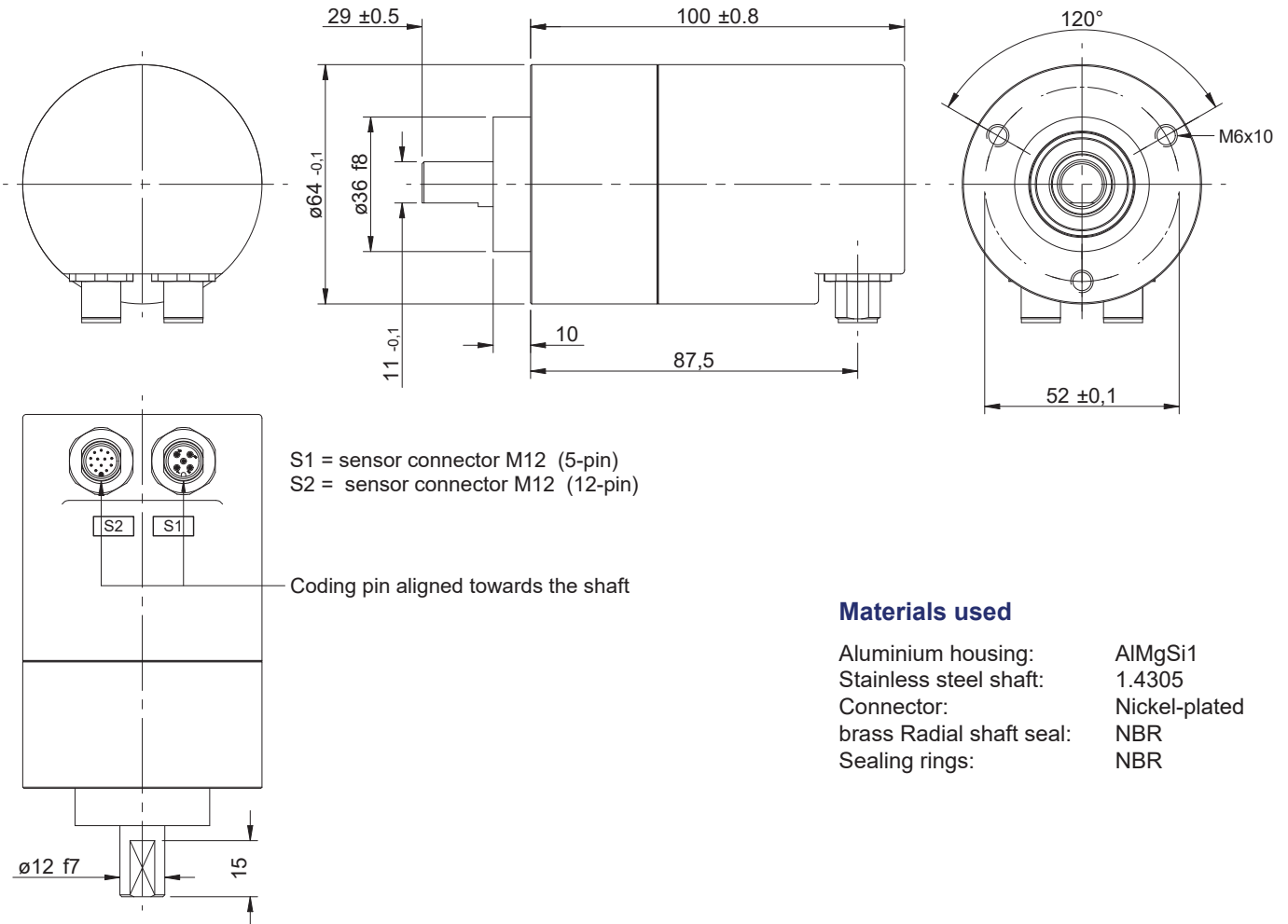

S1 = sensor connector M12 (5-pin)
S2 = sensor connector M12 (12-pin)

Coding pin aligned towards the shaft

Materials used

Aluminium housing:	AlMgSi1
Stainless steel shaft:	1.4305
Connector:	Nickel-plated
brass Radial shaft seal:	NBR
Sealing rings:	NBR

Electronic digital switching cam encoder model NOCN

Installation drawings

Special version NOCN79 on request

Model NOCN79-KZ (2 connectors axial - up to 3 connectors possible)

Dimensions in mm

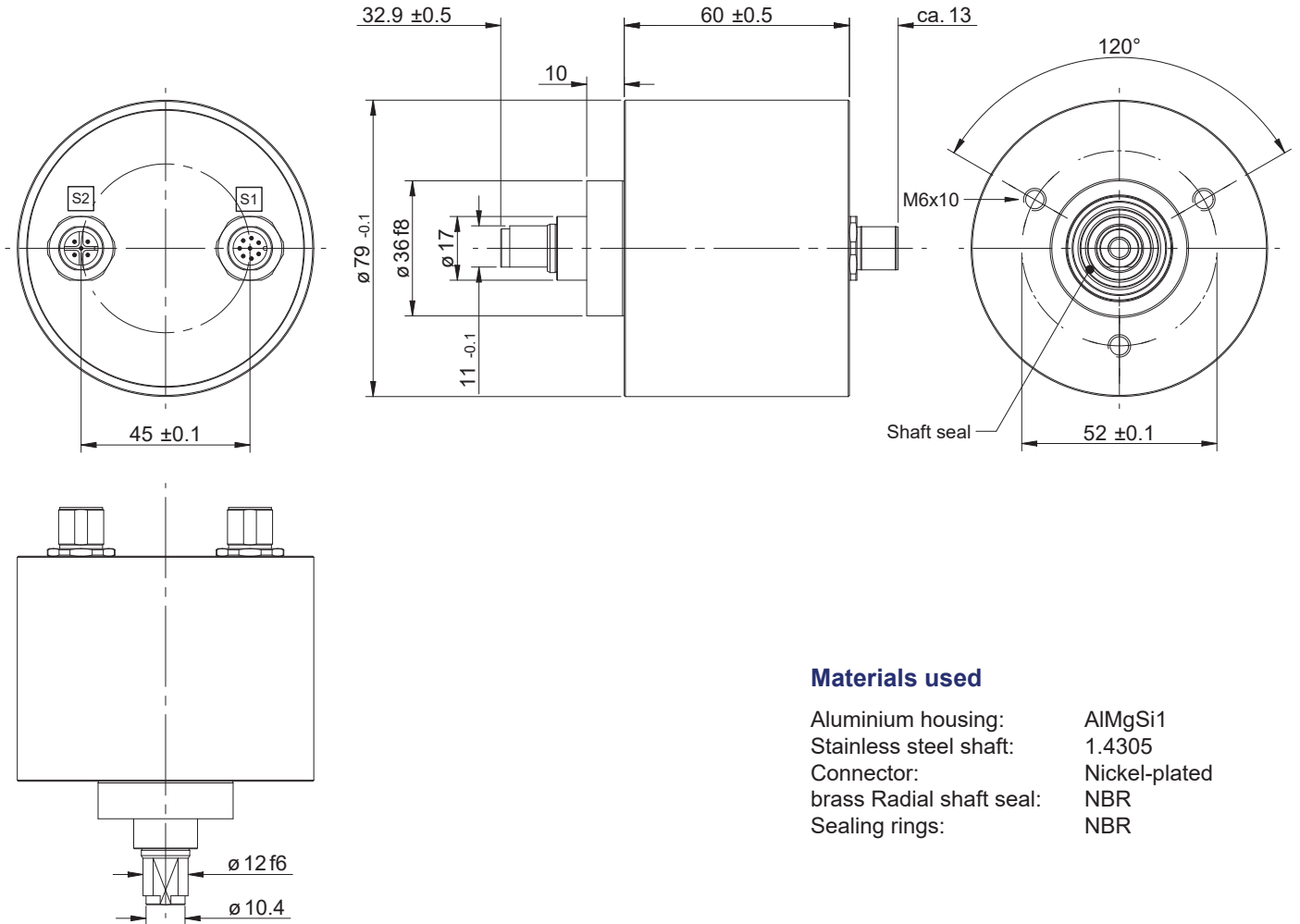

Materials used

Aluminium housing:	AlMgSi1
Stainless steel shaft:	1.4305
Connector:	Nickel-plated
brass Radial shaft seal:	NBR
Sealing rings:	NBR

Electronic digital switching cam encoder model NOCN

Installation drawings

Special version NOCN79 on request

Model NOCN79-KZ (2 connectors radial - up to 3 connectors possible)

Dimensions in mm

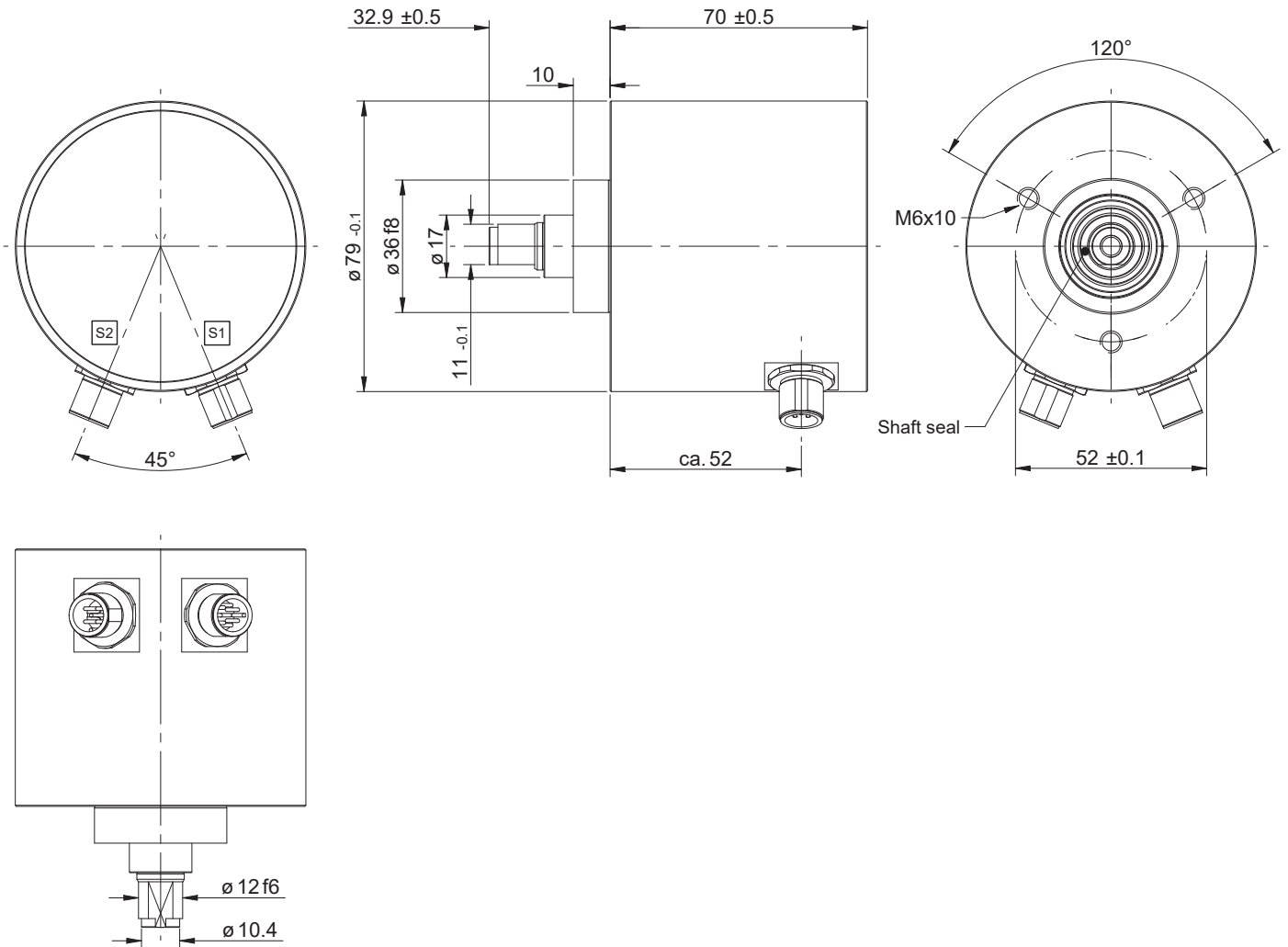

Electronic digital switching cam encoder model NOCN

Installation drawings

(Selection, further drawings on request)

Model NOCN120-M (3 connectors)

Shaft design for connecting the play-compensating toothed gear ZRS

Dimensions in mm

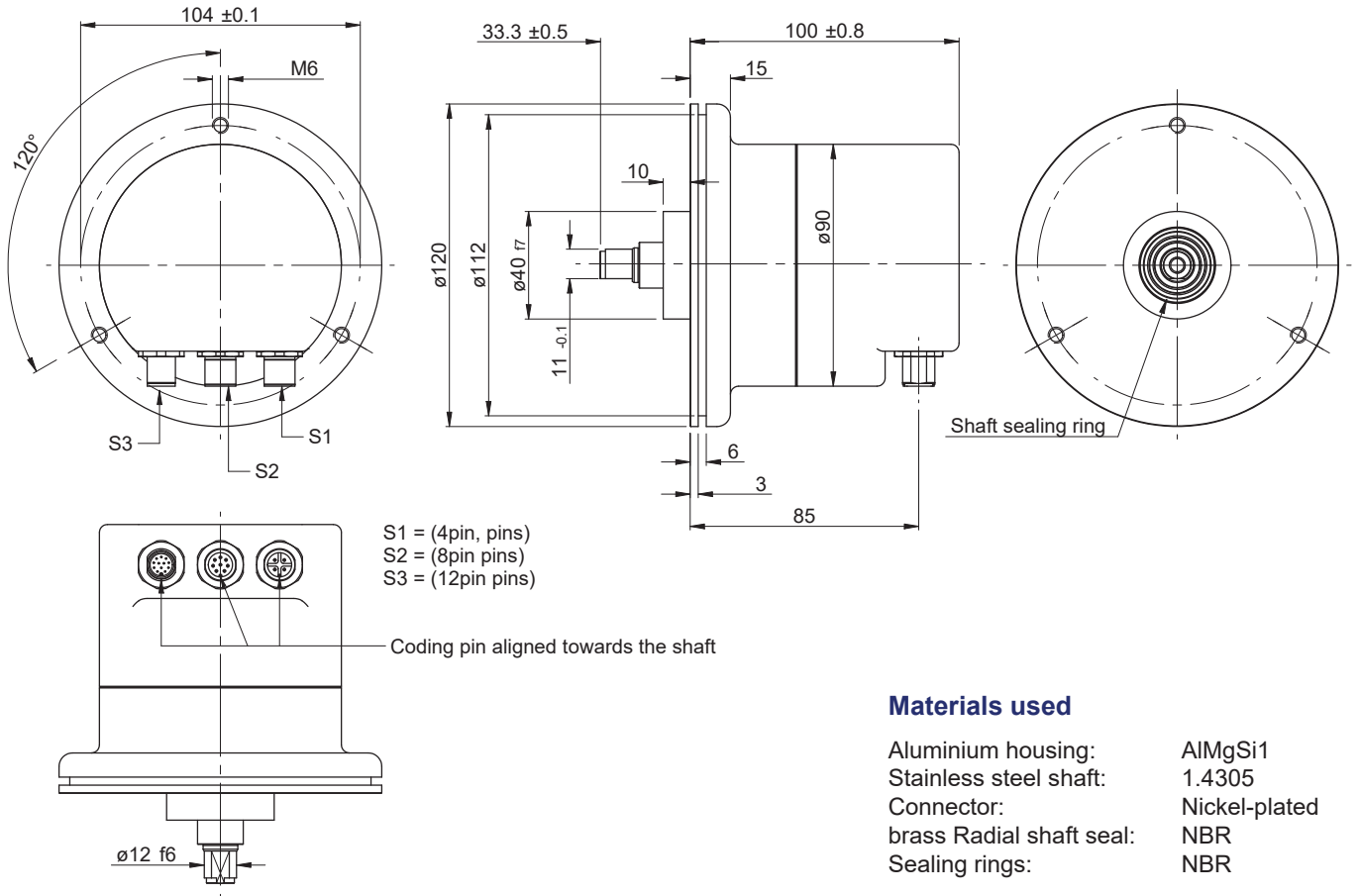

Materials used

Aluminium housing:	AlMgSi1
Stainless steel shaft:	1.4305
Connector:	Nickel-plated
brass Radial shaft seal:	NBR
Sealing rings:	NBR

Accessories

Series KL 58-2 securing clamps

(See data sheet [MZ 10111](#))

- Pitch diameter: 140 ±0.5 mm
- Material: Nickel-plated brass
- Required screws: M4 countersunk head with hexagon socket DIN 7991 (3 units required)

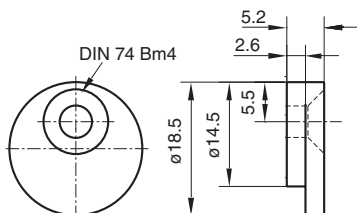

Folding bellows coupling BKK 32/x-y

(See data sheet [BKK 11840](#))

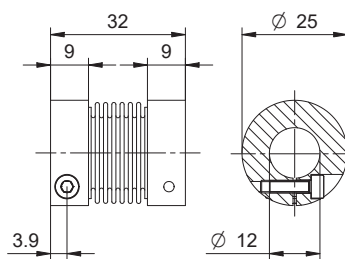

Stainless steel, 1.4301

Clamp coupling KK14S/x-y

(See data sheet [KK 12301](#))

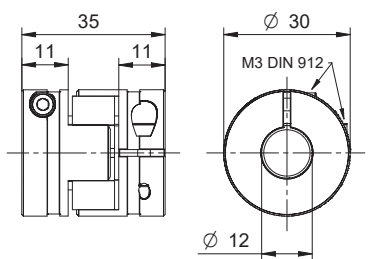

Aluminium / plastic

The couplings are also available with bores for other shaft diameters.

Electronic digital switching cam encoder model NOCN

Play-compensating toothed gear ZRS

(Subject to TWK utility model protection)

A 'play-compensating toothed gear' ZRS is available to mechanically drive the switching cam encoder shaft on a ring gear (slewing ring) or a rack without play. Different modules and numbers of teeth are available. ZRS material: polyamide. Also see data sheet [ZRS 11877](#). Mechanical connection necessitates a specific shaft version.

Installation recommendation: tighten 6 mm bolt to a torque of 6 Nm and secure with Loctite (medium adhesive strength).

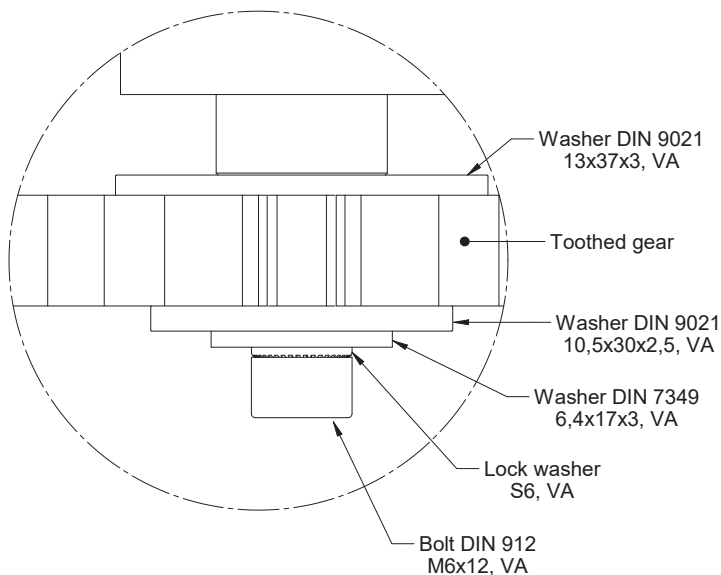
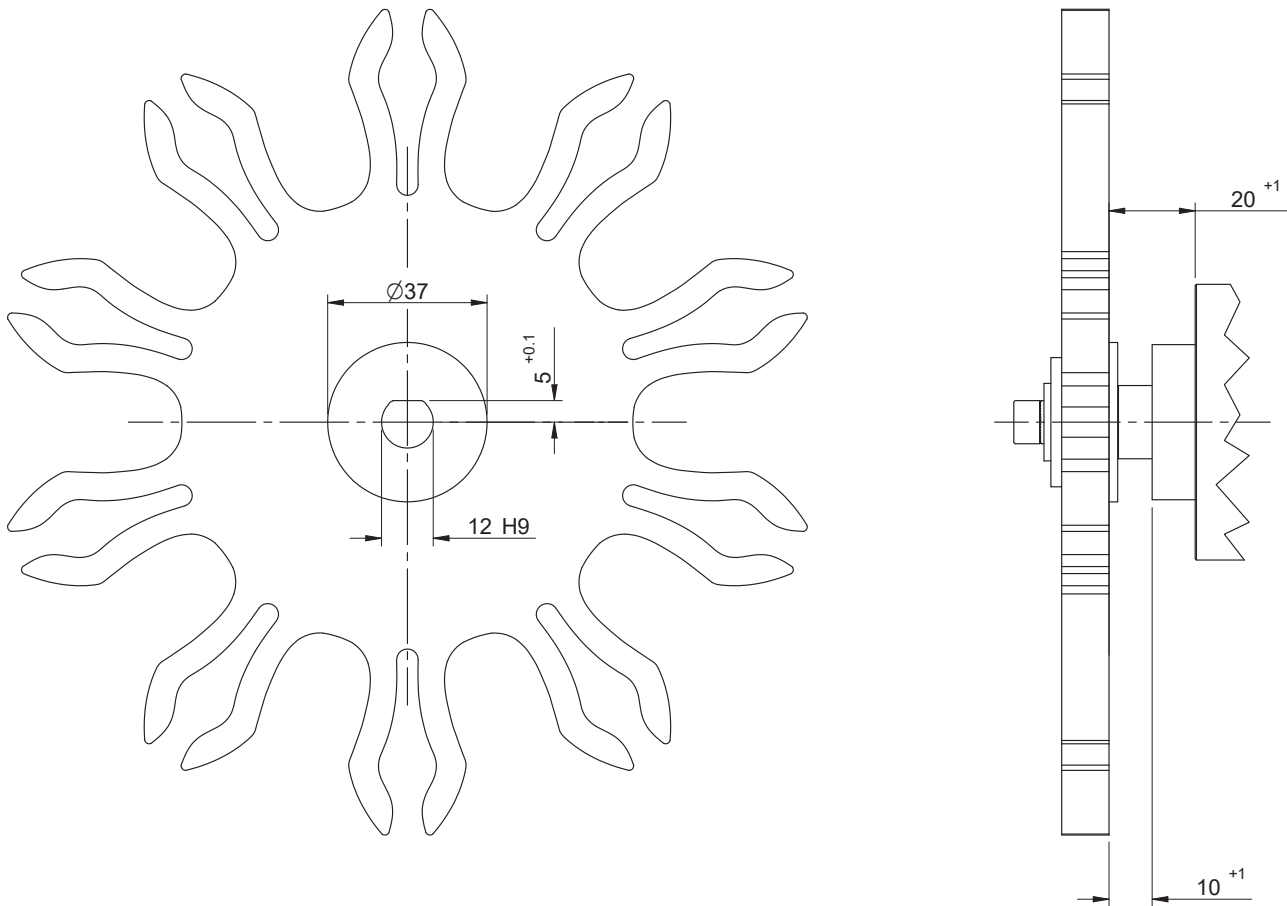

Order code number

ZRS - 12 - 10 - A 01

Variants **:

A 01 Standard

Teeth:

10 No. of ZRS teeth *

Module:

12 5 to 24 *

Model:

ZRS toothed gear, play-compensating model

*: Other values on request

** : Please contact our technical support to select the required measuring gear.

Electronic digital switching cam encoder model NOCN

Programming example for CANopen output and relays / cams

Example programming for relay 1 and relay 2, CANopen: resolution 4096 S/R							
The CANopen output signal has the following offset at an angle reference value of 0: 0° (e.g. 1000): 0							
Output value	Rotation direction	Relay 1 Flank 1 = relay ON	Relay 1 Flank 2 = relay OFF		Relay 2 Flank 1 = relay ON	Relay 2 Flank 2 = relay OFF	
Angle value [°]	cw	0	14,400		32,400	46,800	
No. of revolutions	"	0	40		90	130	
Interface [step]	"	0	163,840		368,640	532,840	
Preset value [step]	163,840						

Example programming for cams 1 and 2, output signal CANopen.

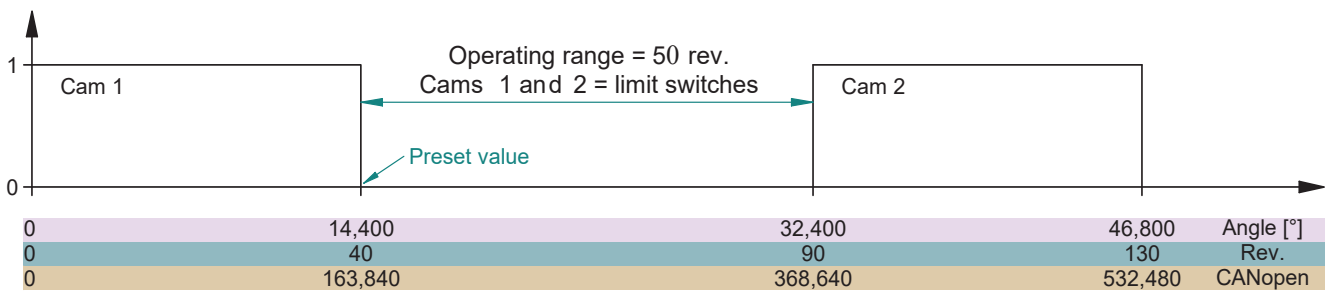

Note: On activation of the preset function, the CANopen signal and therefore also the switching outputs are set. The cams are assigned to specific CANopen position values in the factory. In this example, the CANopen output value is preset to 163,840 and thus also the two cams' four flanks, which lie at 0, 163,840, 368,640 and 532,480.

The procedure for cam 2 (3, 4) is the same. The preset function always refers to the CANopen output signal and the cams at the same time.

Electronic digital switching cam encoder model NOCN

Table for factory programming according to customer specifications

Please enter your desired pre-programming for the switching outputs in the table. A maximum of three cams (switching on/off processes) in the measuring range per switching output. Enter the values (CANopen step values) at which the switching flanks are to lie. Delivery from the factory is then carried out with this programming. In the CANopen version, the programming can be changed in part.

On digital output of the rotary encoder signal, the resolution is always 4096 steps per revolution over the entire measuring range (16 or 256 or 4096 revolutions).

Programming as desired by the customer							
CANopen has the following offset (number of steps) at an angle reference value of 0° (e.g. 10,000):							
Output value	Rotation direction	Relay ____ Flank ____	Relay ____ Flank ____	Relay ____ Flank ____	Relay ____ Flank ____	Relais ____ Flank ____	Relay ____ Flank ____
Angle value [°]							
No. of revolutions							
Interface [step]							
Preset value [step]							

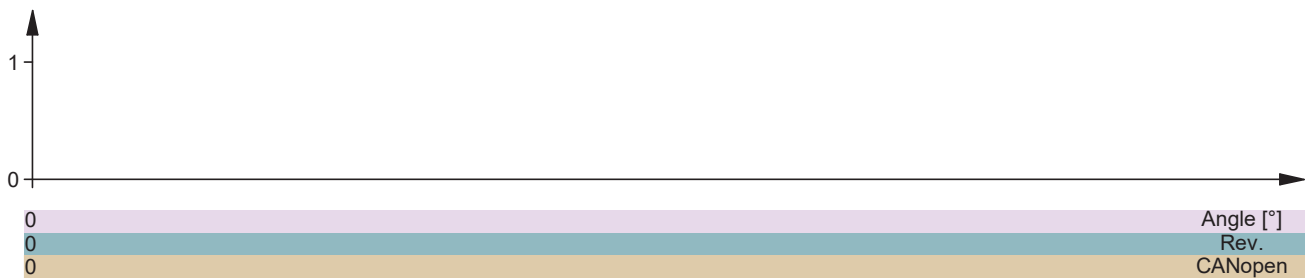

In the above charts you can enter how the cam switch should be programmed.