

B50 C50

Smart Camera / Vision-Sensor / 1D-/2D-Code-Scanner / OCR Reader



Operating Instructions

Table of Contents

1. Use for Intended Purpose	8
2. Safety Precautions	8
3. Approvals and protection class	8
4. Technical Data	9
4.1. Available weQube Sensor Types	9
4.1.1. Sensors with Monochrome Image Chip	9
4.1.2. Sensors with monochrome image chip and C-mount.....	9
4.1.3. Sensors with Color Image Chip and Autofocus.....	10
4.1.4. Sensors with color image chip and C mount.....	10
4.2. List of Technical Data	11
4.3. Connection Diagrams	12
4.4. Housing Dimensions	14
4.5. Control Panel.....	14
5. Installation and Connection	15
5.1. General Installation Instructions.....	15
5.2. System Overview.....	15
5.3. Accessory Products	17
5.3.1. Matching Mounting Technology.....	17
5.3.2. Matching Connection Technology	17
5.3.2.1. Connector Cables	17
5.3.2.2. Connection Cable	17
5.3.2.3. Connecting Module.....	18
5.3.2.4. Interface Cable	18
5.4. LED Display	19
5.5. Initial Start-Up.....	20
5.5.1. Cable Connection.....	20
5.5.2. Sensor Network Settings.....	20
5.5.2.1. Adjusting Sensor Network Settings Manually	20
5.5.2.2. Adjusting Sensor Network Settings Automatically via DHCP Server	21
5.5.2.3. Initial Start-Up of the weQube at a Controller.....	21
5.6. Default Settings	22
6. Functions Description, OLED Display	23
6.1. Run	24
6.2. Teach-In	25
6.3. Teach+	25
6.4. Display	26
6.4.1. Intensity	26
6.4.2. Mode.....	27
6.5. Assistant	28
6.6. Projects.....	29
6.6.1. Current Project	29
6.6.2. Loading a Project	29
6.6.3. Selecting the Start Project.....	30
6.7. Configuration.....	30
6.8. Interface.....	30
6.8.1. Serial interface.....	30
6.8.2. Ethernet	31
6.8.2.1. DHCP.....	31

6.8.2.2. IP Address	31
6.8.2.3. MAC Address	32
6.8.2.4. Network Reset	32
6.9. Language	32
6.10. Info.....	33
6.11. Restart	33
6.12. Reset.....	33
6.13. Password.....	34
6.14. Status Information	34
7. Installing and Updating the Software.....	35
7.1. Minimum Requirements	35
7.2. Installation Procedure	35
7.3. Updating the Software	35
8. Updating the Firmware.....	36
8.1. Firmware Update via weQube Software	36
8.2. Firmware Update via FTP-Interface.....	38
8.3. Upgrade and Downgrade Options	38
9. License Management	39
10. General Layout of weQube Software	40
10.1. Initial Window	40
10.1.1. Connecting the Sensor (Connect to Device)	41
10.1.1.1. Device list	41
10.1.1.2. The Search Network Window	42
10.1.1.3. The File Manager	44
10.1.1.4. Properties	45
10.1.2. Open	47
10.1.2.1. Project File	47
10.1.2.2. Teach+ File	47
10.1.2.3. Template Files	47
10.1.3. Demo Projects	48
10.2. User Interface	49
10.2.1. Common Layout Features.....	50
10.2.2. The Menu Bar	51
10.2.2.1. File.....	51
10.2.2.2. User accounts	51
10.2.2.3. Settings	54
10.2.2.4. View	55
10.2.2.5. Help	56
10.2.2.6. User Mode.....	56
10.2.2.7. Closing the Project.....	56
10.2.3. Modifiable Windows and Areas.....	57
10.2.3.1. Navigation Area, Settings/Results, Function Field	57
10.2.3.2. Image Container Viewer.....	58
10.2.3.3. Profile	60
10.2.3.4. Histogram.....	60
10.2.3.5. Toolbox.....	61
10.2.3.6. Network Tools.....	61
10.2.3.7. Process Times.....	62
10.2.3.8. Project Tools.....	62
10.2.3.9. Module Tools	65

10.2.3.10. Online Data Monitoring Module.....	65
10.2.4. Image Area.....	67
10.2.5. The Status Bar.....	67
11. Software Module	68
11.1. Application Module	68
11.1.1. Overview	68
11.1.2. Setting Parameters.....	68
11.2. Camera Device Module.....	69
11.2.1. Overview	69
11.2.2. Setting Parameters.....	69
11.2.2.1.White Balancing	73
11.2.3. Configuration.....	73
11.2.3.1. Image Sensor.....	74
11.2.3.2. Readout Box Sub-Module.....	74
11.2.3.3. Auto-Focus Box.....	75
11.3. Module Localizer.....	76
11.3.1. Overview	76
11.3.2. Settings.....	77
11.3.3. Configuration.....	78
11.3.3.1. Coordinate System	78
11.3.3.2. Search Box.....	78
11.3.3.3. Teach Image.....	79
11.3.3.4. Teach Box.....	79
11.4. Module Coordinate System	80
11.4.1. Overview	80
11.4.2. Settings.....	81
11.4.3. Configuration.....	82
11.4.3.1. Coordinate System	82
11.4.3.2. Construction Method	82
11.5. Module Region	93
11.5.1. Overview	93
11.5.2. Settings.....	94
11.5.3. Configuration.....	96
11.5.3.1. Region.....	96
11.5.3.2. Set	97
11.6. Module Filter.....	98
11.6.1. Overview	98
11.6.2. Settings.....	99
11.6.3. Configuration	102
11.6.3.1. Output Image	102
11.7. Module Threshold	102
11.7.1. Overview	102
11.7.2. Settings.....	103
11.7.2.1.Magic Wand	105
11.7.3. Configuration.....	106
11.7.3.1. Output Image	106
11.8. Module Threshold HSV.....	107
11.8.1. Overview	107
11.8.2. Settings.....	109
11.8.3. Configuration.....	110
11.8.3.1. Output Image	110
11.8.3.2. Hue.....	110

11.8.3.3. Value.....	111
11.8.3.4. Saturation.....	111
11.9. Module Cluster.....	111
11.9.1. Overview.....	111
11.9.2. Settings.....	112
11.9.3. Configuration.....	113
11.9.3.1. Cluster List.....	114
11.10. Module Measure.....	114
11.10.1. Overview.....	114
11.10.2. Settings.....	115
11.10.2.1. Find Line.....	116
11.10.2.2. Find Circle.....	118
11.10.2.3. Measure Distance.....	120
11.10.2.4. Measure Intersection.....	121
11.10.2.5. Measure Segment on Line Sub-Module.....	122
11.10.2.6. Measure Segment on Circle Sub-Module.....	123
11.10.2.7. Measure Segment on Arc Sub-Module.....	124
11.11. Module Code 1D.....	126
11.11.1. Overview.....	126
11.11.2. Settings.....	126
11.11.3. Configuration.....	127
11.11.3.1. Reading List.....	127
11.11.3.2. Search Box.....	128
11.11.3.3. Enhanced Parameter.....	128
11.12. Module Code 2D.....	131
11.12.1. Overview.....	131
11.12.2. Settings.....	132
11.12.3. Configuration.....	133
11.12.3.1. Reading List Sub-Module.....	133
11.12.3.2. Search Box.....	135
11.12.4. General settings for all Code Types.....	136
11.12.5. Data Matrix ECC 200.....	137
11.12.6. QR Code.....	138
11.12.7. PDF417.....	139
11.13. Module Image Comparison.....	140
11.13.1. Overview.....	140
11.13.2. Settings.....	140
11.13.3. Configuration.....	142
11.13.3.1. Output Image.....	142
11.13.3.2. Reference Image.....	143
11.13.3.3. Threshold Image.....	143
11.14. Module OCR (optical character reader).....	144
11.14.1. Overview.....	144
11.14.2. Parameter Settings.....	144
11.14.3. Configuration.....	145
11.14.3.1. Results List.....	145
11.14.3.2. Segment List.....	145
11.14.3.3. Search Region.....	146
11.14.3.4. Find Lines.....	146
11.14.3.5. Binarization.....	147
11.14.3.6. Segmentation.....	148
11.14.3.7. Classification.....	149

11.14.3.8. Insert.....	149
11.14.3.9. Teaching Characters In	150
11.15. OCR-Tip.....	151
11.15.1. Basic Character Geometry.....	152
11.15.1.1. Examples.....	152
11.15.2. Size of the ROI.....	152
11.15.2.1. Examples.....	153
11.15.3. Background.....	153
11.15.4. Contrast	153
11.15.4.1. Examples.....	154
11.16. Module Pattern Match.....	154
11.16.1. Overview.....	154
11.16.2. Setting Parameters.....	154
11.16.3. Configuration.....	159
11.16.3.1. Results List Sub-Module	159
11.16.3.2. Search Box Sub-Module.....	159
11.16.3.3. Teach Box.....	160
11.16.3.4. Shape Model.....	160
11.16.4. Tips	161
11.17. Module Match Code.....	162
11.17.1. Overview.....	162
11.17.2. Settings.....	163
11.17.2.1. Number Elements	163
11.18. Module Logic.....	164
11.18.1. Overview.....	164
11.18.2. Settings.....	164
11.19. Module Math	165
11.19.1. Overview.....	165
11.19.2. Settings.....	165
11.20. Module Numeric Comparison.....	166
11.20.1. Overview.....	166
11.20.2. Settings.....	166
11.21. Device IO Unit	167
11.21.1. Overview.....	167
11.21.2. Settings.....	167
11.21.3. Configuration	167
11.21.3.1. IO Timings	168
11.21.3.2. Digital I/Os 1 to 6 Sub-Module.....	172
11.21.3.3. Error Handling.....	173
11.22. Device Display.....	174
11.22.1. Overview.....	174
11.22.2. Settings.....	174
11.22.3. Configuration	174
11.22.3.1. Text.....	174
11.22.3.2. Indication.....	175
11.22.3.3. Numeric.....	175
11.22.3.4. Match code	175
11.22.3.5. Teach.....	176
11.22.4. Error Handling	176
11.23. Device Indicator	177
11.23.1. Overview.....	177
11.23.2. Settings.....	177

11.23.3. Error Handling	177
11.24. Device Communication	178
11.24.1. Overview	178
11.24.2. Settings	178
11.24.3. Configuration	178
11.24.3.1. RS-232	179
11.24.3.2. Industrial Ethernet	180
11.24.3.3. UDP	182
11.24.3.4. FTP or SD Card	183
11.24.4. Error Handling	184
11.25. Module Statistics	185
11.25.1. Overview	185
11.25.2. Settings in the Statistics Module	185
11.25.3. Configuration	186
11.25.3.1. Channel # 1	186
12. Project Change via Digital I/O	187
12.1. Software Settings	187
12.2. Procedure	188
13. Network Settings	188
14. Web-Based Configuration	189
14.1. Invoking the Administration Interface	189
14.2. Page Layout	190
14.3. Device, General	190
14.4. Device Settings	192
14.5. Projects	193
14.6. Teach-In	194
14.7. Image	194
15. Maintenance Instructions	195
16. Proper Disposal	195
17. Exclusion of Liability	195
18. Appendix	196
18.1. Setting up an FTP Server at a PC	196
18.2. weQube status information	197
18.3. Coordinate system	198
18.3.1. Right handed coordinate system	198
18.3.2. Image sensor coordinate system	199
18.3.3. Image coordinate system	199
18.3.4. Input coordinate system	200
18.4. Network Settings	200
18.5. weQube Software Module States	201
18.6. weQube Software Module States	202
18.7. Changelog operating instructions	232
18.8. Software changelog	233
18.8.1. Firmware changelog	233
18.8.2. Software changelog	236
19. EU Declaration of Conformity	242

1. Use for Intended Purpose

The wenglor weQube is an optoelectronic sensor which is used for contactless inspection of specific objects.

The sensor unites a camera unit, illumination, optics with auto-focus and an analysis module in a single housing. The sensors work with a CMOS color or monochrome image sensor.

Image processing functions including measurement, object counting, checking for the presence of objects, pixel comparison, shape analysis and reference image comparison can be configured by means of a PC or laptop via the integrated Ethernet port. 1D and 2D codes can be read as well.

These image processing functions can be executed in trigger mode operation, as well as during continuous monitoring, and objects can be detected regardless of position thanks to tracking. Six convertible I/O switching outputs are available, which can be used as either inputs or outputs. Beyond this, an external lamp can also be connected to the weQube, and the integrated illumination can be partially or completely switched off.

2. Safety Precautions

- These instructions are an integral part of the product and must be kept on hand for the entire duration of its service life.
- Read the operating instructions carefully before using the product.
- This sensor is not suitable for safety applications.
- Installation, initial start-up and maintenance of the product should only be carried out by qualified personnel.
- Protect the sensor against mechanical influences.
- Tampering with or modifying the product is impermissible.
- Protect the sensor against contamination during initial start-up.
- The mounting screws must have a thread engagement length of 5 to 7 mm.

3. Approvals and protection class



4. Technical Data

4.1. Available weQube Sensor Types

4.1.1. Sensors with Monochrome Image Chip

Sensor type	Light		White Light	IR	Red Light
	Connection				
weQube Vision	Ethernet		B50S002	B50S003	-
			B50S005	B50S006	-
	Industrial Ethernet		B50S101	B50S102	-
			B50S104	B50S105	-
weQube Decode	Ethernet		C50C001	C50C002	C50C003
	Industrial Ethernet		C50C100	C50C101	C50C102
weQube	Ethernet		B50M002	B50M003	B50M004
	Industrial Ethernet		B50M101	B50M102	B50M104
weQube OCR	Ethernet		B50R001	-	-
	Industrial Ethernet		B50R100	-	-
	Ethernet		-	B50R002	-
	Industrial Ethernet		-	B50R101	-

4.1.2. Sensors with monochrome image chip and C-mount

Sensor type	Connection	Monochrome
weQube Vision	Ethernet	B50S012
		B50S014
	Industrial Ethernet	B50S111
		B50S113
weQube Decode	Ethernet	C50C011
	Industrial Ethernet	C50C110
weQube OCR	Ethernet	B50R011
	Industrial Ethernet	B50R110
weQube	Ethernet	B50M012
	Industrial Ethernet	B50M111

4.1.3. Sensors with Color Image Chip and Autofocus

Sensor type	Light	
	Connection	White light
weQube Vision	Ethernet	B50S001
		B50S004
	Industrial Ethernet	B50S100
		B50S103
weQube	Ethernet	B50M001
	Industrial Ethernet	B50M100

4.1.4. Sensors with color image chip and C mount

Sensor type	Connection	Monochrome
weQube Vision	Ethernet	B50S011
		B50S013
	Industrial Ethernet	B50S110
		B50S112
weQube	Ethernet	B50M011
	Industrial Ethernet	B50M110

4.2. List of Technical Data

Optical Characteristics	
Working range	≥ 20 mm (weQube with auto-focus)
Resolution	736 px × 480 px
Field of vision	See "Range of Vision Table"
Image chip	See section 4.1 on available sensor types
Type of light	See section 4.1 on available sensor types
Refresh rate (monochrome)	≤ 25 Hz
Refresh rate (color)	≤ 15 Hz
Service life	100,000 hours
Risk group (EN 62471)	Free group
Electrical Characteristics	
Supply power *	18 to 30 V DC
Current consumption (operating voltage = 24 V)	< 200 mA
Response time (monochrome)	< 40 ms
Response time (color)	< 66 ms
Temperature range	-25...55 °C **
Number of digital I/Os	6
Switching output voltage drop	< 2.5 V
Switching output switching current	100 mA
Short-circuit proof	Yes
Protected against polarity reversal	Yes
Overload-proof	Yes
Protection class	III
Interfaces	Ethernet 10/100 Base TX; Ethernet or Profinet (see section 4.1 on available sensor types)
Mechanical Characteristics	
Configuration interface	Ethernet port
Housing material	Aluminum
Protection	IP67
Connector type	M12×1, 12-pin
Ethernet connector type	M12×1, 8-pin
Configurable as PNP, NPN or push-pull	Yes
Can be switched to NC or NO operation	Yes
Illumination output	Yes
RS-232 interface	Yes ***
General Data	
Webserver	Yes (all Ethernet and Industrial Ethernet Devices, see section "4.1. Available weQube Sensor Types")

* Supply voltage residual ripple may not exceed 10 % (within the specified voltage range).

** -25 °C: Ambient conditions should not result in condensation; avoid the formation of ice on the front panel!

55 °C: Continuous illumination at max. 1 % or flash mode at 100 % brightness with an exposure time of ≤ 5 ms: may affect the service life of the product.

*** Maximum connection length: 30 m

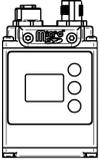

Range of vision table (weQube with auto-focus):

Working distance	20 mm	100 mm	200 mm	1000 mm	5000 mm
Range of vision	16×12 mm	64×48 mm	120×90 mm	600×450 mm	3000×2250 mm

Range of vision for C mount variant depends on the utilized lens.

4.3. Connection Diagrams

Plug No. 1

Plug No. 2

1008

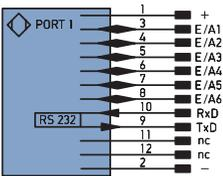

002

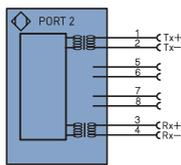

Explanation of Symbols

Legend

+	Supply Voltage +	PT	Platinum measuring resistor	ENa	Encoder A
-	Supply Voltage 0 V	nc	not connected	ENb	Encoder B
~	Supply Voltage (AC Voltage)	U	Test Input	AMin	Digital output MIN
A	Switching Output (NO)	Ū	Test Input inverted	AMax	Digital output MAX
Ā	Switching Output (NC)	W	Trigger Input	AOK	Digital output OK
V	Contamination/Error Output (NO)	O	Analog Output	SY In	Synchronization In
Ṽ	Contamination/Error Output (NC)	O-	Ground for the Analog Output	SY OUT	Synchronization OUT
E	Input (analog or digital)	BZ	Block Discharge	Out	Brightness output
T	Teach Input	Aw	Valve Output	M	Maintenance
Z	Time Delay (activation)	a	Valve Control Output +	rsv	reserved
S	Shielding	b	Valve Control Output 0 V		
RxD	Interface Receive Path	SY	Synchronization		
TxD	Interface Send Path	E+	Receiver-Line		
RDY	Ready	S+	Emitter-Line		
GND	Ground	≡	Grounding		
CL	Clock	SnR	Switching Distance Reduction		
E/A	Output/Input programmable	Rx+/-	Ethernet Receive Path		
 IO-Link		Tx+/-	Ethernet Send Path		
PoE	Power over Ethernet	Bus	Interfaces-Bus A(+)/B(-)		
IN	Safety Input	La	Emitted Light disengageable		
OSSD	Safety Output	Mag	Magnet activation		
Signal	Signal Output	RES	Input confirmation		
Bl_D-v-	Ethernet Gigabit bidirect. data line (A-D)	EDM	Contactor Monitoring		
EN15522	Encoder 0-pulse 0-0̄ (TTL)	EN15522	Encoder A/Ā (TTL)		
		EN15522	Encoder B/B̄ (TTL)		

Wire Colors according to DIN IEC 757

BK	Black
BN	Brown
RD	Red
OG	Orange
YE	Yellow
GN	Green
BU	Blue
VT	Violet
GY	Grey
WH	White
PK	Pink
GNYE	Green/Yellow

Note: If you use wenglor connection cables, you'll find the corresponding wiring diagram in section 5.3.2.1.

4.4. Housing Dimensions

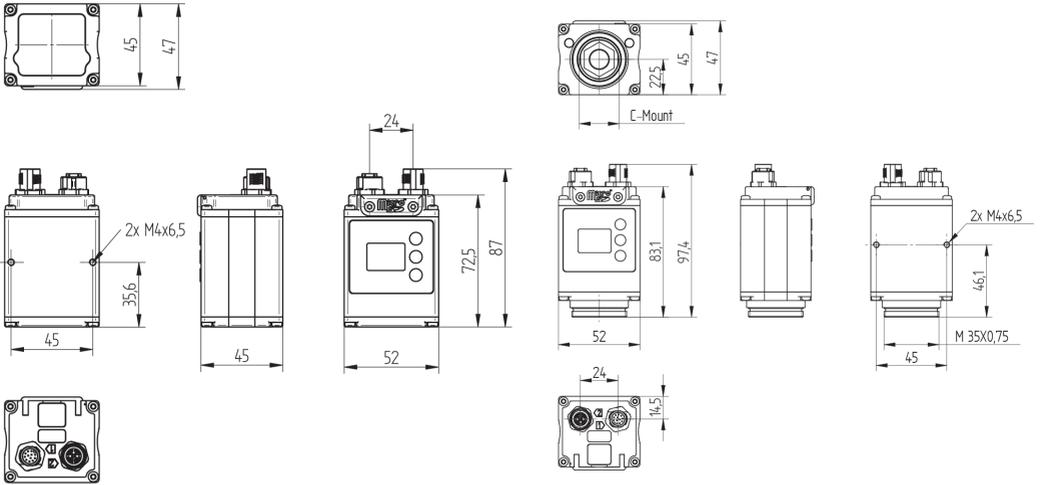

4.5. Control Panel



- 1 Up key
- 2 Enter key
- 3 Down key
- 4 Display

5. Installation and Connection

5.1. General Installation Instructions

All applicable electrical and mechanical regulations, standards and safety precautions must be adhered to when installing and operating the sensor. The sensor must be protected against mechanical influences. Install the weQube such that its installation position cannot be inadvertently changed. The wenglor mounting system is recommended for installing the sensor. It must be assured that the mounting screws have a thread engagement length of 5 to 7 mm.

5.2. System Overview



Connection Cable

M12, 8-pin to RJ45	
ZC1V001 (straight)	2 m
ZAV50R502 (straight)	5 m
ZC1V002 (straight)	10 m
ZC1V009 (angled)	2 m
ZC1V010 (angled)	5 m
ZC1V011 (angled)	10 m

Connector Cables

M12, 12-pin to open end	
ZDCL001 (straight)	2 m
ZDCL002 (straight)	5 m
ZDCL003 (straight)	10 m
ZDCL004 (angled)	2 m
ZDCL005 (angled)	5 m
ZDCL006 (angled)	10 m

Interface Cable

M12, 12-pin to RS-232	
ZDCG002	

Connection Cable

M12, 12-pin to M12, 12-pin	
ZDCV001	2 m
ZDCV002	5 m
ZDCV003	10 m

Connection Cable

M12, 4-pin to M12, 4-pin	
BW2SG2V1-2M	2 m
BG2SG2V1-2M	2 m
BG2SG2V3-2M	2 m

Connecting Module

M12, 12-pin to trigger / illumination	
ZDCG001	

Mounting System

ZMBID1202	
ZMWZF0001	

Alternative Micro SD Card

ZNNG013*	
----------	--

Protection Housing

ZSZ-02-01	
ZSZ-03-01	

Lens

LAC9-14-K01	9 mm
LAC25-14-K02	25 mm
LAC35-16-K02	35 mm

Illuminations

Further information is available > here

Legend

- Required accessories ————
- Optional accessories - - - - -
- Included in delivery *

Licenses:

ZNN1003	PC license, offline operation, 1D/2D code module
DNNL002	License, 1D/2D code module
DNNL001	License, vision module
DNNL003	License, OCR-Modul

Operating instructions:

ZNNG044	Operating instructions on CD
---------	------------------------------

5.3. Accessory Products

5.3.1. Matching Mounting Technology

ZMBID1202	Mounting System
ZMWZF0001	Mounting Bracket for illumination technology

5.3.2. Matching Connection Technology

5.3.2.1. Connector Cables

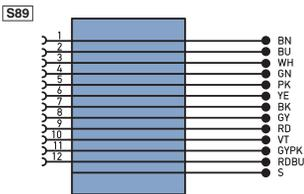

ZDCL001	M12×1 connector cable, 12-pin, 2 m, straight
ZDCL002	M12×1 connector cable, 12-pin, 5 m, straight
ZDCL003	M12×1 connector cable, 12-pin, 10 m, straight
ZDCL004	M12×1 connector cable, 12-pin, 2 m, angled
ZDCL005	M12×1 connector cable, 12-pin, 5 m, angled
ZDCL006	M12×1 connector cable, 12-pin, 10 m, angled

Note: The wiring diagram for the weQube is included in section 4.3.

5.3.2.2. Connection Cable

ZC1V001	M12×1 connection cable, 8-pin, 2 m, to RJ45
ZAV50R502	M12×1 connection cable, 8-pin, 5 m, to RJ45
ZC1V002	M12×1 connection cable, 8-pin, 10 m, to RJ45
ZDCV001	M 12×1 connection cable, 12-pin, 2 m
ZDCV002	M 12×1 connection cable, 12-pin, 5 m
ZDCV003	M 12×1 connection cable, 12-pin, 10 m

5.3.2.3. Connecting Module

ZDCG001

M12x1 connecting module, 12-pin to trigger, illumination

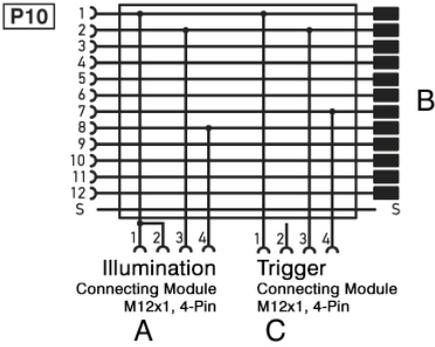

5.3.2.4. Interface Cable

ZDCG002

M12x1 interface cable, 12-pin to RS-232

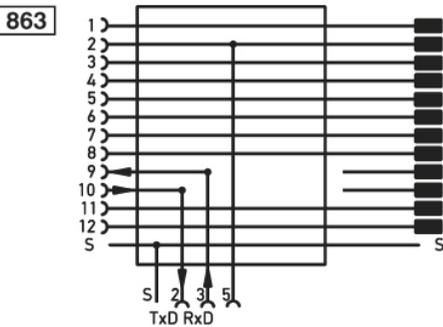

5.4. LED Display

The LEDs on the back of the weQube indicate the following (rear view of the weQube with display at top):

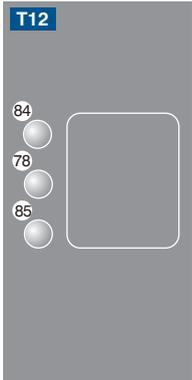

Profinet

LED	Function
84	Communication status
78	Module status
85	Link/act LED

Designation	Status	Function
CS (communication status) (only available with Profinet devices)	Off	Connection (AR) established with controller
	Green	Protocol not initialized
	Red	No connection (AR) to controller
MS (module status) (only available with Profinet devices)	Red	Error (class: fatal)
	Blinking red	Detection function, can be switched on via engineering tool
L/A	Green	Link available
	Blinking green	Communication

Ethernet/IP

LED	Function
84	Network status
78	Module status
85	Link/Act-LED

Description	Status	Function
NS (Network status)	Off	No IP address
	green	CIP connection
	Blinking green	IP configured, no CIP connection
	red	Duplicate IP address
	Blinking red	CIP connection Timeout
MS (Module status)	Off	-
	green	Device works
	Blinking green	Standby
	red	Fatal error
	Blinking red	Device error
L/A	Off	No Ethernet device connected
	green	Link available
	Blinking green	communication

5.5. Initial Start-Up

5.5.1. Cable Connection

Connect the sensor (socket 2) to the Ethernet port at the PC or the controller and connect socket 1 to power supply (see section 5.2). Power supply must be between 18 and 30 V DC.

Caution: Make sure that the cables have been correctly and securely connected, assuring good physical contact. The sensor's micro SD card may not be removed during operation. If the micro SD card will be replaced, disconnect the sensor from power supply first.

5.5.2. Sensor Network Settings

Upon shipment from the factory, the weQube's IP address is **192.168.100.1** and its subnet mask is **255.255.255.0**.

The following options are available for establishing a connection with the sensor.

5.5.2.1. Adjusting Sensor Network Settings Manually

In order to be able to connect the sensor to your PC, you have to make sure that the sensor and your PC are both within the same IP address range.

Ascertain your PC's IP address and subnet mask to this end.

Note: You can ascertain the network settings of your Windows PC by clicking start, entering “cmd” to the “Search programs and files” line and then pressing the enter key. A command line appears. After entering “ipconfig” to this line, the PC’s network settings are displayed.

If necessary, change the weQube’s subnet mask, so that it coincides with the PC’s. The subnet mask breaks the IP address down into a network part (places in the subnet mask occupied by the digits “255”) and a device part (places in the subnet mask occupied by digits other than “255”).

The network part of the weQube’s IP address must coincide with the network part of the PC’s IP address, and the device parts of the weQube and the PC must be different.

Example:

The following subnet mask is used for both the PC and the sensor: **255.255.255.0**.

If the PC’s IP address is **192.100.100.1**, the IP address of the weQube must start as follows: **192.100.100**. The last digit of the IP address must differ from the PC’s last digit, and should only occur once throughout the network. For example, the following IP address could be used for the weQube: **192.100.100.2**.

You can change the sensor’s network settings with the help of weQube software (see section 10.1.1.2).

Alternatively, you can also change the sensor’s IP address at the OLED display (see section 6.8.2).

Caution: It may be necessary to deactivate the PC’s firewall in order to establish connection with the sensor. Detailed information about deactivating the Windows firewall can be found in the general instructions included on the weQube product page.

5.5.2.2. Adjusting Sensor Network Settings Automatically via DHCP Server

If the weQube is connected to a DHCP server, activate dynamic host configuration at the sensor either with the help of weQube software (see section 10.1.1.2) or at the OLED display (see section 6.8.2). A suitable IP address and subnet mask are assigned to the sensor when it’s restarted.

5.5.2.3. Initial Start-Up of the weQube at a Controller

If you want to place the weQube into service at a controller, please complete the following steps:

- Connect weQube to the controller. The display at the sensor is activated when supply voltage is applied.
- Install the associated device-specific electronic description file to the hardware manager (e.g. the GS-DML for Profinet). The required file can be downloaded from www.wenglor.com → **Product World** → **Product search** (Order No.) → **Download**. Explanations regarding the electronic description file and its layout are included in the comprehensive operating instructions in PDF format.
- Help regarding installation of the file to the controller, as well as network planning, can be found in the help files for the respective controller. wenglor offers descriptions for individual controllers which can be downloaded from: www.wenglor.com → **Product World** → **Product search** (Order No.) → **Download**.

Caution: When operated with a controller, settings which have been changed via the website or the OLED display are overwritten by the controller.

5.6. Default Settings

		weQube		
Teach ⁺	Number of frames	10		
Display	Intensity	Screensaver		
	Mode	Text		
Interface	Ethernet	Serial	Baud rate	115.200
			DHCP	Off
			IP Adress	192.168.100.001
			Subnet mask	255.255.255.000
			MAC Adress	See label on Sensor
			Std. gateway	192.168.100.254
			TCP/IP Port	32001
Language		English		
Password	Enable	Disable		
	Change	2013		

6. Functions Description, OLED Display

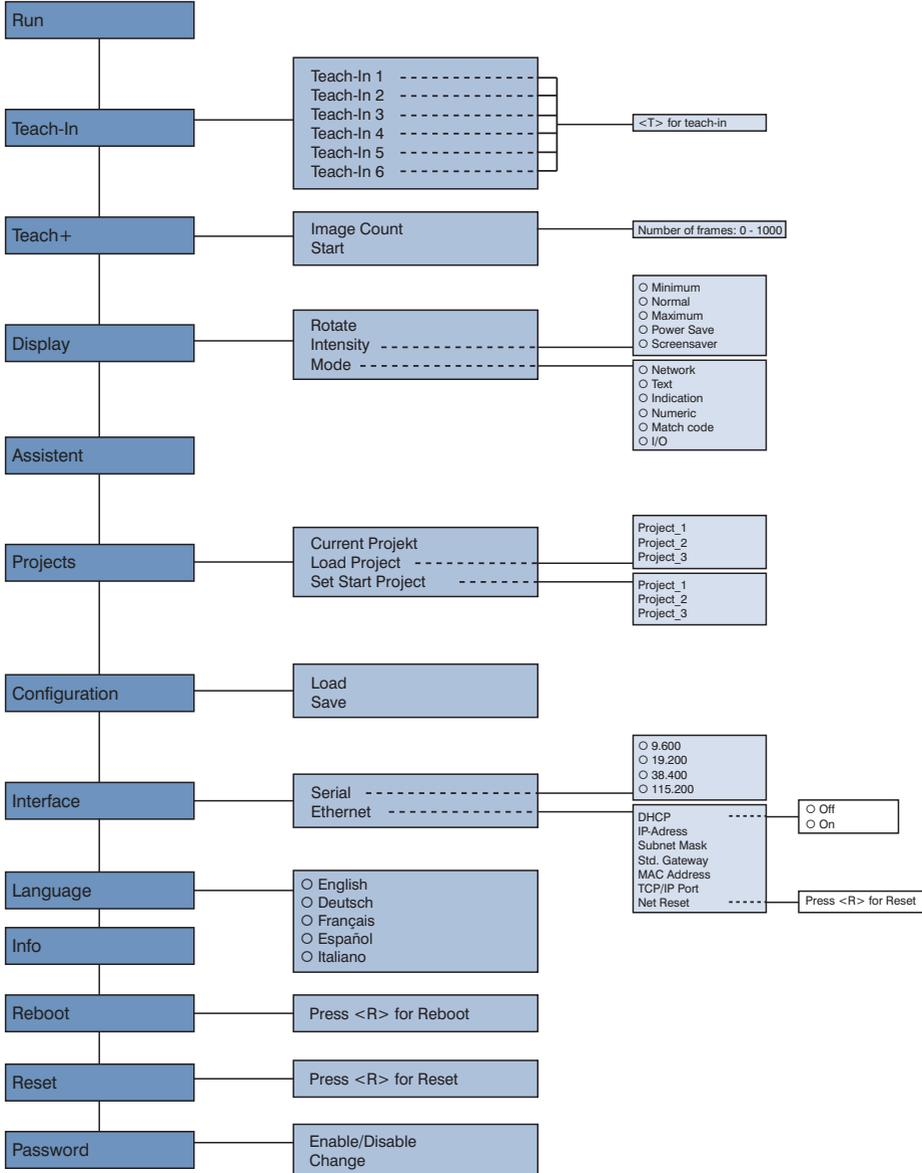

The first time the sensor is started and after each reset, language selection and the assistant appear at first (see section 6.9).



Navigation with the keys:

▲ : Navigate up

▼ : Navigate down.

↵ : Enter key

You can switch to the configuration menu by pressing any key.

Meanings of menu items:

◀ Back: Move up one level within the menu.

◀◀ Run: Switch to the display mode.

You can switch to the configuration menu by pressing any key.

Note: If no settings are adjusted in the configuration menu for a period of 30 seconds, the sensor is automatically returned to the display mode. The sensor accesses the last used menu view when a key is once again activated. If a setting is configured, it becomes active when the configuration menu is exited.

Caution: Do not use any sharp objects to press the keys when configuring settings, because they might otherwise be damaged.

6.1. Run

The sensor is switched to the display mode.

The text mode is the default setting for the display mode. The display mode can be changed to the network mode, the status mode, the numeric mode or the match code mode in the display menu (see section 6.4.2).

6.2. Teach-In

Subsequent sensor teach-in is possible with the display. Up to six teach options can be taught-in in this way. The parameters which are assigned to the memory locations is determined by means of the PC software. Upon delivery, no parameters are assigned to the teach-in memory locations.

Teach-In	Select memory location for teach-in
Teach-In 1 Teach-In 2 Teach-In 3 Teach-In 4 Teach-In 5 Teach-In 6 ◀ Back ◀◀ Run	Selection of up to 6 different memory locations for teaching in objects subsequently. Note: In order to be able to teach in a given object to the sensor via the OLED display, the desired teach-in function must first be linked to the corresponding teach-in memory location at the display with the help of the software (see section 11.22.3.5).

Execute teach-in using the selected memory location.

Teach-In 1		Teach in certain object to the sensor.
Press <T> to teach in.	T ◀	Teach-in procedure: 1) Align the sensor to the desired object. 2) Press the "T" key -> the parameter value is taught in.

6.3. Teach+

In the case of Teach+, entire image sequences are saved to a compressed file, including all settings for the current project, for example interface settings etc. This file can be transferred to the PC with the help of weQube software (see section 10.2.3.8).

Teach+		Execute Teach+
Number of frames Start ◀ Back ◀◀ Run		Number of frames: Select the number of frames for the Teach+ process. Start: Start archive generation for the Teach+ process. A Teach+ procedure which has been started can be aborted by pressing the "C" key.

You can adjust the number of frames for the Teach+ process to meet your own individual requirements.

Number of frames		Select the number of frames for teach-in.
10	+ ◀ -	Press the "+" or "-" key in order to set the number of frames for the Teach+ process to a value between 0 and 1000.

Note: Quicker scrolling through numbers is made possible by pressing and holding the respective key.

6.4. Display

Various changes can be made to the settings at the display in order to simplify operation of the sensor.

Display	Display settings	
Rotate Intensity Mode ◀ Back ◀◀ Run	Rotate:	Rotate the display 180°. The display is rotated 180° by pressing the ↵ key. The display can be returned to its original position by pressing the same key once again.
	Intensity:	Adjust display intensity.
	Mode:	Selection of various display modes for the “Run” mode

6.4.1. Intensity

Display intensity can be adjusted, for example to assure that the display is still easily legible even in bright environments.

Display	Adjusting display intensity	
<input type="radio"/> Minimum <input type="radio"/> Normal <input type="radio"/> Maximum <input type="radio"/> Energy saving <input type="radio"/> Screensaver ◀ Back ◀◀ Run	Minimum:	Display intensity is set to the smallest possible value.
	Normal:	Display intensity is set to the middle value.
	Maximum:	Display intensity is set to the highest possible value.
	Energy saving:	If no keys are pressed for a period of one minute, the display is switched off, and is switched back on as soon as a key is activated.
	Screensaver:	If no keys are pressed for a period of 30 seconds, the display is switched to the display mode and returns to the last used menu as soon as a key is activated.

6.4.2. Mode

The weQube display is equipped with various display modes which can be used as default settings for the run mode.

Mode	Selection of the display for the “Run” mode					
<ul style="list-style-type: none"> <input type="radio"/> Network <input type="radio"/> Text <input type="radio"/> Status <input type="radio"/> Numeric <input type="radio"/> Match code <input type="radio"/> I/O ◀ Back ◀◀ Run 	<p>Network:</p> <p>Error:</p> <p>Text:</p> <p>Status:</p> <p>Numeric:</p> <p>Match code:</p> <p>I/O:</p>	<p>The statuses of the various networks are displayed in the “Run” mode (TCP/IP, FTP, Profinet). Possible status displays: online: The sensor is connected via the network. offline: The sensor is not connected to the network. Check sensor connection.</p> <p>There are problems with network connection.</p> <p>In addition to the sensor name, any desired sensor values can be displayed in the “Run” mode. Refer to section 11.22.3.1 regarding configuration of the test display in the software.</p> <p>The statuses of the 6 different Boolean parameters are displayed in the “Run” mode. The following symbols may appear (see section 11.22.3.2):</p> <table border="1" style="margin-left: 20px;"> <tr> <td style="text-align: center;">●</td> <td>Switched</td> </tr> <tr> <td style="text-align: center;">○</td> <td>Not switched</td> </tr> </table> <p>Display of the selected value, as well as the upper and lower thresholds in bar graph format (see section 11.22.3.1).</p> <p>The saved parameter, e.g. a barcode with which scanned codes are compared, is displayed in the “Run” mode. Refer to section 11.22.3.4 on how to save a match code.</p> <p>The statuses of the 6 outputs are displayed in the “Run” mode. E1 to E6 for input 1 to 6 and A1 to A6 for outputs 1 to 6. O = not specified.</p>	●	Switched	○	Not switched
●	Switched					
○	Not switched					

6.5. Assistant

The assistant is started automatically when the sensor is switched on for the first time, and each time the sensor settings are reset. However, it can also be started manually in order to simplify project selection and sensor configuration.

		Starting the Assistant
<p>The assistant helps you in selecting the most important settings in accordance with your requirements. Do you want to enter further settings? Press Y for yes or N for no, briefly press ◀ to go back and press and hold ◀ to exit.</p>	Y	Start the assistant by pressing the “Y” key.
	N	After pressing the “N” key, the assistant is exited and the display is switched to the full menu.
	◀	After briefly pressing the ◀ key once, the scrolling text for using the assistant is started again. The assistant is exited after briefly pressing the ◀ key twice, and the display is switched to the full menu. By pressing and holding the ◀ key, the assistant is exited and the display is switched to the configuration menu.

When using the assistant, you’re provided with the following assistance for setting up the sensor:

		Loading the configuration from the SD card
<p>Load configuration from SD card?</p>	Y	If you want to transfer the settings from the SD card to the sensor, press the “Y” key.
	N	Caution: Current sensor settings are overwritten!
	◀	If you do not want to overwrite the existing sensor configuration with the settings saved to the SD card, press the “N” key.
		Press the ◀ key in order to return to the initial assistant window.

		Loading a project from the SD card
<p>Load project from SD card?</p>	Y	If you want to transfer projects which have been stored to the SD card to the sensor, press the “Y” key.
	N	Caution: The project which is currently selected at the sensor is overwritten!
	◀	If you do not want to select a project which has been saved to the SD card, press the “N” key.
		Press the ◀ key in order to return to configuration selection in the assistant.

		Exiting the assistant
You have completed all of the steps offered by the assistant. Do you want to run the assistant again?	Y	If you want to run the assistant again, press the “Y” key.
	N	After pressing the “N” key, the assistant is exited and the display is switched to the display mode.
	◀	After briefly pressing the ◀ key once, the scrolling text is started again. After briefly pressing the ◀ key twice, project selection is displayed in the assistant.

6.6. Projects

The weQube system provides you with the opportunity of loading projects to the sensor which have been saved to the SD card, as well as defining start projects.

Projects	Project Management
Current project Load project Set start project ◀ Back ◀◀ Run	<p>Current project: The name of the current project is displayed.</p> <p>Load project: A stored project included in the project list, or a new project, can be loaded. It will be displayed only the first 50 projects, that are stored on the SD card.</p> <p>Set start project: One project must be specified as the start-up project. This project is executed automatically when the sensor is started.</p>

6.6.1. Current Project

Current project	Display of the current project
Project name	<p>◀ The title of the currently loaded project is displayed.</p> <p>Press the ◀ key in order to return to configuration selection in the assistant.</p>

6.6.2. Loading a Project

Load project	Load a project to the sensor which has been stored to the SD card.
Project_1 Project_2 Project_3 ◀ Back ◀◀ Run	Any given project can be selected and loaded to the sensor. The project name appears in abbreviated form.

6.6.3. Selecting the Start Project

Set start project	Selecting the start project
Project_1 Project_2 Project_3 ◀ Back ◀◀ Run	You can select a project from the project list in the “Set start project” menu, which is then selected automatically when the sensor is started.

6.7. Configuration

Configuration	Managing sensor settings
Load Save ◀ Back ◀◀ Run	<p>Load: Settings saved to the SD card are loaded to the sensor.</p> <p>Save: Settings currently loaded to the sensor are saved to the SD card. In the event that the sensor is replaced, configuration of the new sensor is simplified by simply replacing the SD card.</p> <p>Caution: The previously stored sensor configuration is overwritten during the save operation.</p>

6.8. Interface

In addition to its serial port, the sensor is also equipped with an Ethernet port

Interface	Interface selection
Serial Ethernet ◀ Back ◀◀ Run	<p>Serial: The baud rate can be selected for the serial port.</p> <p>Ethernet: Settings for the Ethernet port can be configured.</p>

6.8.1. Serial interface

Activate	Baud rate selection for the serial port
<input type="radio"/> 9,600 <input type="radio"/> 19,200 <input type="radio"/> 38,400 <input type="radio"/> 115,200 ◀ Back ◀◀ Run	Communication via the serial port can take place at various transmission speeds. Changes do not become effective until after the sensor has been restarted.

6.8.2. Ethernet

Ethernet	Settings for the Ethernet connection
DHCP IP address Subnet mask Std. gateway MAC address TCP/IP port Network reset ◀ Back ◀◀ Run	DHCP: Display: DHCP on or DHCP off IP address: Display of the selected IP address Subnet mask: Display of the selected subnet mask Std. gateway: Display of the selected standard gateway MAC address: Display of the preselected, non-changeable MAC address TCP/IP port: Display of the TCP/IP port Network reset: Resets network settings to their default values Changes do not become effective until after the sensor has been restarted.

6.8.2.1. DHCP

DHCP	DHCP server selection
<input type="radio"/> Off <input type="radio"/> On ◀ Back ◀◀ Run	It's possible to activate or deactivate assignment of the network configuration to the sensor via a server.

6.8.2.2. IP Address

IP address	Setting the IP address
192168100001 + ↵ -	The IP address can be set by pressing the “+” and “-” keys.

IP address	Checking the IP address for correctness
192.168.100.001 Entry correct? Y N ◀	Correctness of the entered IP address is confirmed by pressing the “Y” key and the address is transferred to the sensor. If necessary, the IP address can be reentered after pressing the “N” key. After pressing the ◀ key, the display is returned to the Ethernet network menu without saving the entered IP address.

The procedure for changing the subnet mask, the standard gateway and the TCP/IP port is analogous to entering the IP address.

6.8.2.3. MAC Address

MAC Address	Displaying the MAC Address
54:4a:05:00:08:04 ◀	The sensor's unchangeable MAC address is displayed. After pressing the ◀ key, the display is returned to the Ethernet network menu.

6.8.2.4. Network Reset

Network reset	Resetting the Network Configuration
Press R <R> to reset. ◀	The network configuration can be reset by pressing "R". After pressing the ◀ key, the display is returned to the Ethernet network menu.

Refer to section 5.6 regarding default network settings.

6.9. Language

The menu language can be changed in the "Language" menu. The user is automatically prompted to select a language when the sensor is first started up, as well as after each reset.

Language	Selecting a menu language
<input type="radio"/> English <input type="radio"/> Deutsch <input type="radio"/> Français <input type="radio"/> Español <input type="radio"/> Italiano <input type="radio"/> ◀ Back <input type="radio"/> ◀◀ Run	The selected language appears in the menus as soon as it has been selected.

6.10. Info

Info	Display of sensor information
Sensor type B50S001	Sensor type, product version, serial number and status are displayed in the information menu.
Product version 1.0.0	These entries play an important role in the event that technical problems should occur, and when contacting Technical Support with questions.
Serial number 504215773	

6.11. Restart

Restart	Restarting the sensor
Press <R> to restart.	<p>R Restating of the sensor can be forced by pressing “R”.</p> <p>◀ After pressing the ◀ key, the display is returned to the main menu.</p>

6.12. Reset

Sensor settings (except for network settings) can be returned to their default values in the “Reset” menu. The default settings are listed in section “5.6. Default Settings” on page 22.

Reset	Restore default settings
Press <R> to reset.	<p>R All of the selected sensor settings are returned to their default values by pressing the “R” key.</p> <p>◀ After pressing the ◀ key, the display is returned to the main menu.</p>

6.13. Password

Password protection prevents inadvertent changes to selected settings.

Password	Activating the password function
De/activate Change ◀ Back ◀◀ Run	De/activate: Activate or deactivate password protection. When password protection is activated, the sensor is automatically disabled after pressing any in the “Run” mode. Change: Change the password.

If the password function is active, the password must be entered each time the sensor is operated. After the password has been correctly entered with the “+” and “-” keys, the menu is enabled and the sensor can be operated.

- The password function is deactivated upon shipment from the factory.
- Passwords can be selected within a range of 0000 to 9999.

Be sure to make a note of the new password before exiting the “change password” function! If the password is forgotten, it must be overwritten with a master password. The master password can be requested by e-mail from **support@wenglor.com**.

6.14. Status Information

In addition to status information and warnings in the “Info” menu, messages are also displayed as symbols in the run window.

weQube ⚠	Critical Error
	A critical error has occurred.

weQube ⚠ 0x01	Fatal Error
	A fatal error has occurred. The sensor must be restarted.

7. Installing and Updating the Software

7.1. Minimum Requirements

- Standard Intel Pentium, 2 GHz, 2 GB RAM
- Operating system: MS Windows XP, 7
- 150 MB available hard disk space (Recommended 500 MB)
- Ethernet interface
- Screen resolution 1024 × 960 (Recommended > 1280 × 1024)

7.2. Installation Procedure

First check to see whether or not a more up-to-date version of the software is available from our website. Additional support for initial start-up as well as further information regarding use of the software can be found on the microsite at www.wenglor.com/weQube.

If the software on the CD is the latest version, proceed as follows:

1. Insert the installation CD into the CD drive.
 2. Run the setup program: "Install_weQube". Administrator rights are required to this end.
 3. Follow the instructions which appear at the screen.
- weQube software is installed.

The language setting for the software is the same as for the operating system. If a different language is desired, it can be selected in the **Settings** menu.

7.3. Updating the Software

1. Uninstall current weQube **software** using the Software function in the **Control Panel**.
2. The latest software version is available from the download area at our website: www.wenglor.com
3. The new software can be installed as described in section 7.2

Before updating the software, make sure that the firmware has been updated to the most recent version. The current version is always available from the download area at wenglor.com.

8. Updating the Firmware

Before setting up the sensor, check to see whether or not a newer version of the firmware is available for the weQube. You can check your sensor's firmware version in the graphic display under Info → Product Version (see section 6.10).

The most up-to-date version of the firmware can be downloaded from our website at:
www.wenglor.com → **Product World** → **Product search (Order no.)** → **Download** → **Software**.

Note: When the firmware is updated, the associated PC-software should be updated at the same time (see section 7.3).

The version number indicates whether or not the versions are compatible with each other: if the last place in the version designation changes, the versions are compatible with each other. If the middle place changes, the versions are not 100 % compatible. If the first place changes, the version are not compatible with each other at all. The exact changes included in the consecutive versions can be viewed in the versions history file in the installation directory under .../wenglor/weQube/ressources/help/changelog.text.

Projects generated with version <1.1.x are not 100 % compatible with version >1.2.x. New functions included with version 1.2.x are not available for version 1.1.x projects.

There are two different ways to execute a firmware update. Connection to the sensor must first be established.

8.1. Firmware Update via weQube Software

The firmware in the weQube can be updated after opening the firmware update dialog window by clicking Firmware Update in the Help menu. The following window appears:

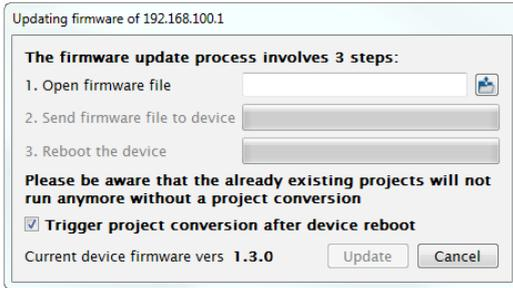

First select the corresponding firmware file and then click the update button. The firmware file is automatically transferred to the sensor, which is then restarted. The firmware update process may not be interrupted. Power to the sensor may not be interrupted during this procedure. Updating takes roughly 10 to 15 minutes.

If project files are located in the sensor's memory, it's advisable to convert them automatically after the update procedure has been completed. The checkbox for "Start project conversion after device restart" must be activated to this end. After the sensor has been restarted, the conversion program is launched.

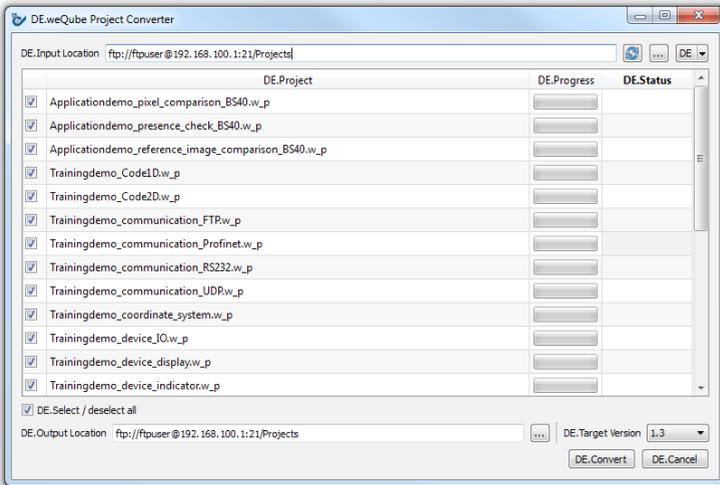

All selected projects are converted to the target version. The version designation is added to the previous project name for the converted projects. And thus Trainingsdemo.w_p becomes Trainingsdemo_V1.3.w_p. The status display for the individual projects indicates the current conversion status. The conversion tool can also be accessed independent of the update procedure by selecting “Project Converter” from the help menu. The conversion function works for older, right on up to new project versions in both directions.

After the process has been successfully completed, a window appears with detailed information regarding the sensor.

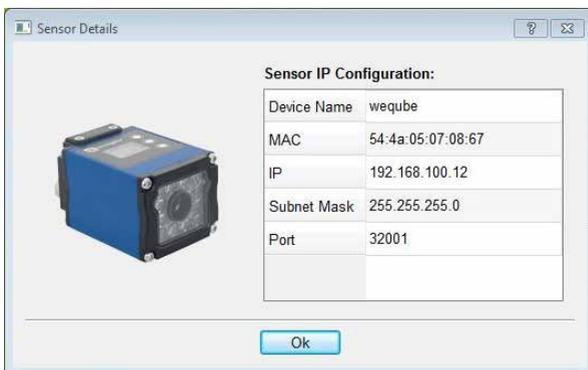

8.2. Firmware Update via FTP-Interface

Connection to the sensor must first be established via an FTP client.

Enter "ftp://" to the address bar in the file explorer followed by the sensor's IP address to this end, for example: ftp://192.168.100.1

The following codes have to be entered in order to access the sensor's micro SD card:

User name: ftpuser

Password

Now copy the downloaded firmware directly to the corresponding location in the file explorer (e.g. ftp://192.168.100.1/UPDT_weQube_1.1.0.tgz). The new firmware is transferred to the sensor's micro SD card. Then restart the sensor via the OLED display (see section 6). The sensor's firmware is updated during the restart. Updating takes roughly 10 to 15 minutes.

8.3. Upgrade and Downgrade Options

Upgrade and downgrade options for weQube firmware are shown in the following figure.

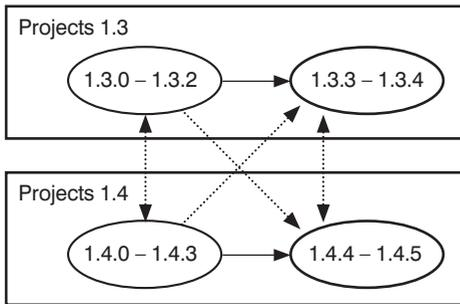

- Upgrade only, no downgrade possible
- Projects are compatible within the identified range
- Upgrade or downgrade possible (no project compatibility → use project converter)
- Upgrade only, no downgrade possible (no project compatibility → use project converter)



NOTE!

From 1.3.0 to 1.3.2: any desired upgrade or downgrade is possible with compatible projects.
From 1.4.0 to 1.4.3: any desired upgrade or downgrade is possible with compatible projects.



NOTE!

After updating weQube firmware to version 1.3.3, 1.3.4, 1.4.4 oder 1.4.5, downgrading to a lower firmware version is no longer possible.

9. License Management

The various products included on the weQube platform vary with regard to available software licenses. Licenses are available for scanning modules, for image processing modules and for offline code reading (see section “5.2. System Overview” on page 15). The scope of functions included with each product can be expanded as desired by purchasing further licenses. In order to open the license view, click licenses in the help menu, which can be accessed in the software’s menu bar.

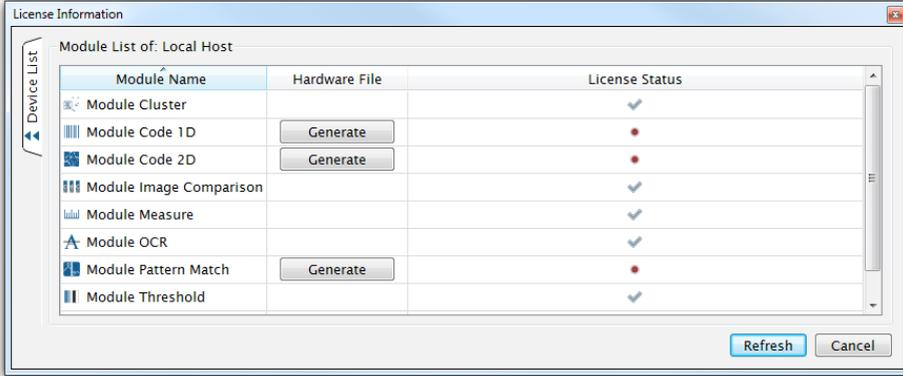

Differentiation must be made between the following two cases:

The software is connected	The sensor’s license status is displayed, including all of its licensed and unlicensed modules.
The software is not connected to the sensor (offline).	In the offline mode, all of the image processing modules are licensed. However, as a default setting the scanning modules are not licensed. Note: The PC license for offline 1D-2D code reading is required for offline code reading (see section 5.2). The USB dongle included with the offline license must always be connected to the PC during offline code reading.

The status of each license is displayed.

- The license for the respective module is included in the current software version.
- The license for the respective module is not included in this software version.

Subsequent ordering of licenses:

A hardware file must first be created before licenses can be subsequently ordered for currently unlicensed modules.

Click the Generate button to this end. Send the resulting file (*.w_l) to wenglor by e-mail. After processing has been completed, you’ll receive an e-mail reply from wenglor with the enabled license as an attachment. Afterwards, a “Load” button appears in the window with the licenses under license status of the respective module. After clicking this button, the received file can be added. The corresponding module is then enabled and appears in the toolbox.

NOTE!



Along with the PC license for 1D-2D code reading, you also receive as USB dongle in addition to the hardware file – located on the accompanying CD. Before transferring the hardware file to your PC, plug the USB stick into your PC and do not remove it during offline code reading.

10. General Layout of weQube Software

Windows software, which is installed to a PC, is utilized to configure, adjust and diagnose the weQube.

10.1. Initial Window

The following initial window appears after the program has been started. Various options are provided by the software.



The software establishes a connection to the sensor.

Note: The sensor must be correctly connected to the PC to this end (see section 5.5).

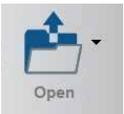

If a project file has been saved to the PC, it can be opened, or any existing project can be selected. Teach+ files can be loaded after changing the file extension to “w_r”.



A demo project can be selected from an applications list. Demo projects show settings used for typical applications with the help of image sequences.

10.1.1. Connecting the Sensor (Connect to Device)

10.1.1.1. Device list

The following window appears after clicking “Connect to Device”:



Note: It's not possible to access the sensor simultaneously with the software and via the website. If applicable, close the website before connecting the software to the sensor. Furthermore, under no circumstances should you make changes in the software and at the OLED display at the same time.

All previously used sensors are displayed in the device list. You can search for a certain sensor in the “Device Quick Search” field, for example by entering its MAC address. The sensors can also be sorted according to various criteria. Simply click the desired heading to this end – for example click “IP” in order to sort the sensors according to IP address. Various sensor information can be added or removed by right clicking the header.

Any sensor displayed in the list can be directly connected to the software by double clicking the respective list entry.

The software starts up in the operating mode. Switch to the editing mode in order to be able to change settings in the software (see section 10.2.3.8).

The following actions can be executed after right clicking a sensor:

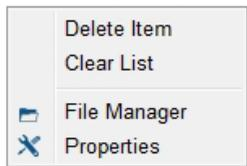

Delete Item	The selected sensor is removed from the list.
Clear List	The entire list is deleted.
Edit Network Settings	The sensor's network settings are edited in a new window, even if the sensor is located in another subnet.
Properties	The sensor's settings can be edited.

10.1.1.2. The Search Network Window

There are no sensors in the list after the software is first installed. The “Search Network” window appears automatically, which can be used to find sensors within the network. Sensors located in another subnet can also be found in this way.

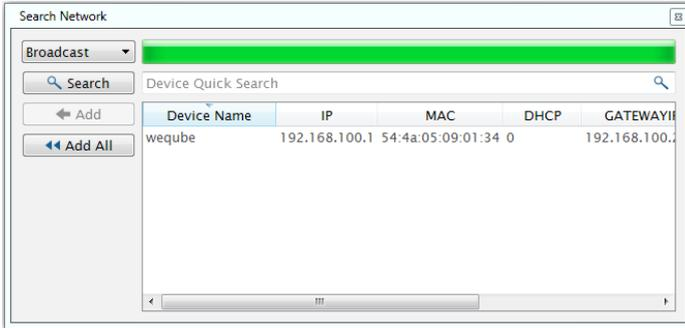

Note: Before adding a found sensor to the device list, it's network settings should be adjusted. Right click the respective sensor to this end, and then click “Edit network settings”.

The following actions can be executed after right clicking a sensor:

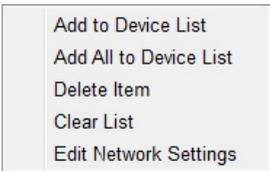

Add to Device List	The selected sensor is added to the list of sensors.
Add All to Device List	The entire list of sensors found in the network is added to the list of sensors.
Delete Item	The selected sensor is removed from the list.
Clear List	The entire list is deleted.
Edit Network Settings	The sensor's network settings can be adjusted in the window shown below.

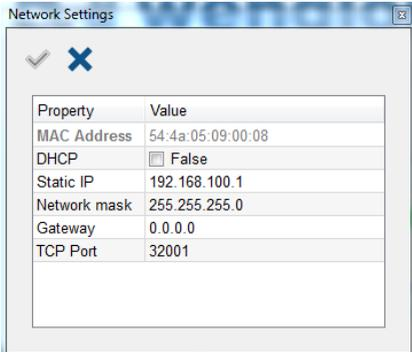

The following options can be selected from the drop down menu under “Broadcast”:

Broadcast	Sensors in another subnet can be found.
IP & Port	You can search for a certain IP address and a certain port after clicking “IP & Port”. The sensors must be located in the same subnet.

The respective search is executed by clicking the “Search” button and all of the sensors which match the search terms are displayed in the combination field under the button along with their corresponding settings. The search can be aborted by clicking the “Stop” button. After clicking the ◀ icon, a selected sensor can be added to the device list. Alternatively, all sensors which appear in the combination field can be added to the device list by clicking the ◀◀ icon. By adding a sensor to the device list you get warned to double check the IP configuration.

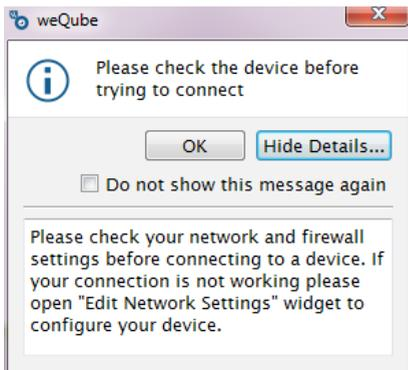

10.1.1.3. The File Manager

Files can be exchanged between the PC and the sensor and moved in the file manager. Access to the installed SD card is possible via the integrated FTP server.

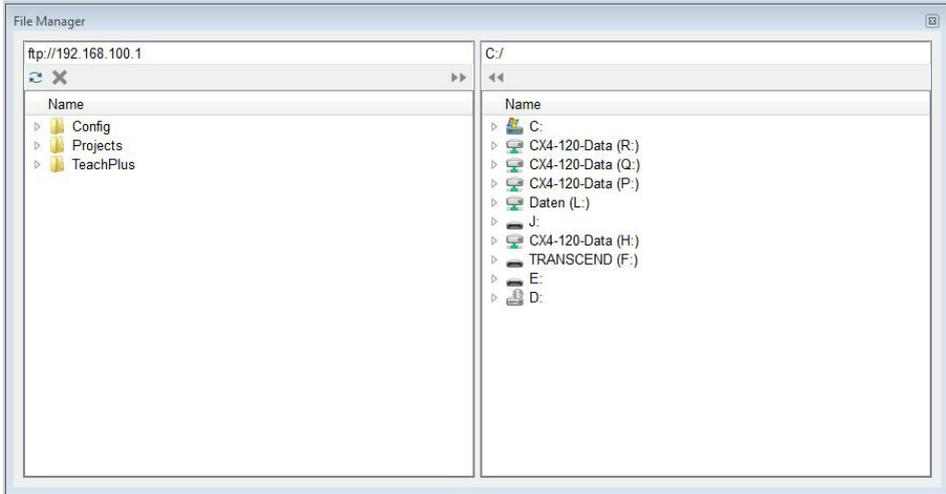

10.1.1.4. Properties

The sensor's system settings are displayed. The following information and settings are available:

Properties of ✖

↻ 📄 ✓

Property	Value
Article Number	B50M002
Description	weQube
Serial Number	500014785
Product Version	0.9.4
Type Of Industrial Ethernet	None
DHCP	<input type="checkbox"/> False
IP-Address	192.168.100.1
Subnet Mask	255.255.255.0
Std. Gateway	192.168.100.255
MAC-Address	54:4a:05:09:00:08
TCP/IP Port	32001
UDP State Interval	0
Enable Industrial Ethernet	<input checked="" type="checkbox"/> True
RS232 Baudrate	115200
Device Name	weQube
Start Project	
Start Focus Value	-1
FTP Remote IP-Address	192.168.100.100
FTP Remote Username	ftpuser
FTP Remote Password	passwd
Web Interface Password	admin
Display Rotation	<input type="checkbox"/> False
Display Password	2013
Display Locked	<input type="checkbox"/> False
Display Mode	Numeric
Display Intensity	Screensaver
Display Language	English

Article Number	The sensor's article number (fixed)
Description	Product name (fixed)
Serial Number	Serial number (fixed)
Product-Version	Product version (fixed)
Type of Industrial-Ethernet	Which type of Industrial Ethernet (Profinet) is available (fixed)
DHCP	Check box for activating the DHCP client
IP-Address	IP-Address Current IP address
Subnet Mask	Current subnet mask
Std. Gateway	Current standard gateway
MAC-Address	Current MAC address
TCP/IP Port	TCP/IP port for communication with the PC software
UDP-State-Interval	Interval in seconds at which service signals (UDP broadcast) are transmitted to port 32003
Enabel-Industrial-Ethernet	Check box for activating Industrial Ethernet communication.
Ethernet Mode	Various modes are available:
ACD Control	Address Conflict Detection. Automatic detection of address conflicts is activated or deactivated (only with Ethernet/IP).
ACD PDU	Indicates which IP address is involved in the event of an IP address conflict (only with Ethernet/IP).
Inactivity Timeout	Indicates time after which a TCP/IP port has been closed, if it wasn't active (only with Ethernet/IP).
Baud rate	Baud rate for the RS-232 interface. Basic setting: 115,200 bps (8 data bits, no parity, 1 stop bit)
Device-Name	The name of the sensor can be made up of the following characters: uppercase and lowercase letters, numbers, dashes (-) and periods (.). The name of the sensor may not begin with "-" or ".".
Start-Project	Specifies which project will be loaded when the sensor is started.
Start-Focus-Value	-1: No focus homing takes place before advancing to the project's stored focal point. 0: Focus homing takes place before advancing to the project's stored focal point.
FTP-Remote-Address	IP address of the FTP server
FTP-Remote-Username	FTP user name
FTP-Remote-Password	FTP password
Display-Rotation	Check box for rotating the display
Display-Password	Current display password
Display-Locked	Check box for activating password protection of the OLED display
Display-Mode	Selection of the OLED mode
Display-Intensity	Selection of OLED intensity
Display-Language	Selection of the OLED language

10.1.2. Open

After clicking the open icon, a project which has been saved to the PC can be opened. The following file formats can be selected:

10.1.2.1. Project File

Project files end with `.w_p`. Sensor settings and a reference image are saved to projects. Projects can be edited both online and offline. They're the standard format for application solutions.

10.1.2.2. Teach+ File

Teach+ files end with `.w_r`. Sensor settings and any desired number of images are saved to Teach+ files. They can be used for documentation and make it possible to change sensor settings in the offline mode from anywhere in the world. Files which have been edited offline can be uploaded to the sensor as a project file, and the settings saved to the Teach+ file are then transferred to the sensor.

10.1.2.3. Template Files

Template files end with `.w_t`. As is also the case with project files, sensor settings and a reference image are saved to template files, but template files cannot be overwritten simply by means of saving.

Creating Individualized Templates

You can set up your own standards for weQube applications by creating individualized templates. They can be used, for example, in order to specify that communication for all applications will take place via Profinet, or that the scanned code always appears at the display.



Templates

Loading Templates for Standard Applications

As a standard feature, several template files are included on the weQube's micro SD card which cover typical applications such as checking for presence, distance measurement, 2D code reading, reference image comparison and cluster counting.

In order to be able to open these templates and use them as a quick solution for standard applications, connection must first be established with the sensor (see section 10.1.1).

The micro SD card can be accessed directly by clicking the open icon (see section 10.2.3.8). After changing the file type to `*.w_t`, all available template files are displayed. After clicking the required template, it's transferred to the sensor. With just a few clicks, you can adjust your settings and save the solution for your application as a project file with the `.w_p` extension.

The most up-to-date template files can be downloaded from our microsite at www.wenglor.com/weqube. After establishing a connection with the sensor, you can select the appropriate template file by clicking the open icon at your PC, and transfer it to the sensor.

10.1.3. Demo Projects

After clicking demo projects, a ready-made demo project can be opened. Differentiation is made between training demos and application demos.

Training Demos



Training Demos



Tutorials

Training demos show sample settings for a software module. The module's mode of operation is made plainly apparent by means of the included image sequence with fictitious objects. A tutorial is available for each training demo on our microsite (www.wenglor.com/weQube), as well as on the included CD, which shows how the demo project was created step by step.

Overview of available training demos and associated tutorials:

Training Demo	Associated Tutorial
Training demo – Localizer	Tutorial 4 – How to localize an object
Training demo – Region	Tutorial 5 – How to set a region of interest
Training demo – Threshold	Tutorial 6 – How to create a binary image in module threshold
Training demo – Cluster	Tutorial 7 – How to count clusters
Training demo – Threshold HSV	Tutorial 8 – How to use the HSV threshold module for colored images
Training demo – Filter	Tutorial 9 – How to filter an image
Training demo – Measure	Tutorial 10 – How to measure an object
Training demo – Reference image comparison	Tutorial 11 – How to compare an image to a reference image
Training demo – 1D barcode	Tutorial 12 – How to read 1D barcodes
Training demo – 2D code	Tutorial 13 – How to read 2D codes
Training demo – Match code	Tutorial 14 – How to match a code with a string
Training demo – Coordinate System	Tutorial 15 – How to track an object independently of its position and orientation
Training demo – Math, logic and numeric comparison	Tutorial 16 – How to do numeric, mathematic or logic operations with output values
Training demo – Digital Inputs Outputs	Tutorial 17 – How to configure weQube's input and output pins
Training demo – Communication FTP	Tutorial 18 – How to set up weQube's communication with FTP
Training demo – Communication RS-232	Tutorial 19 – How to set up weQube's communication with RS-232
Training demo – Communication UDP	Tutorial 20 – How to set up weQube's communication with UDP
Training demo – Communication Profinet	Tutorial 21 – How to set up weQube's communication with Profinet
Training demo – Statistics	Tutorial 22 – How to analyze values statistically
Training demo – Graphic display	Tutorial 23 – How to set up weQube's display
Training demo – Signal LEDs	Tutorial 24 – How to set up weQube's signal LEDs

The training demos can be edited in order to test available setting options.

Application Demos



Application Demos

Application demos demonstrate solutions for complete applications with real objects. They cover typical industrial applications and provide users with a general idea of which settings can be used as solutions for certain applications.

The most important applications are included in the software as demo projects. A complete list of all application demos can be accessed on our microsite at www.wenglor.com/weQube.

10.2. User Interface

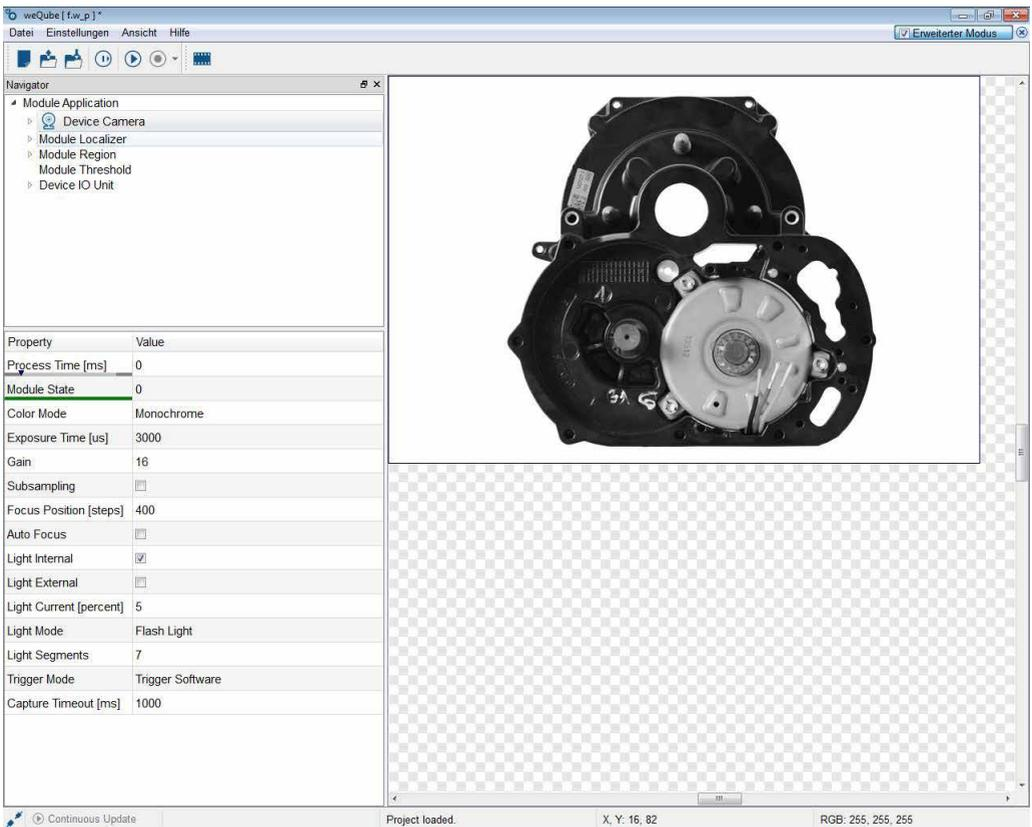

The arrangement of the user interface depicted here shows default software settings during initial use. However, the user interface can be adapted to meet your individual needs.

10.2.1. Common Layout Features

Numerous parts of the user interface can be set up individually. For example, the toolbar and the function field can be set to any desired position. After clicking into the dotted area at the left or at the top (a cross appears at the corresponding location), the area can be detached from the layout. This field can then be positioned at any desired position in the foreground, or it can be docked within the layout by holding the field until the blue area highlights the desired position.

Field to be **moved**

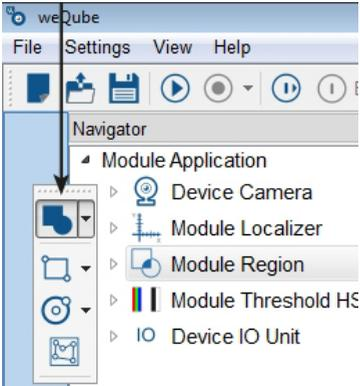

The window navigation field together with settings and results, the image container viewer, the profile, the module toolbox, the histogram and the device list area can be freely positioned or docked. These areas are characterized by the following common layout.

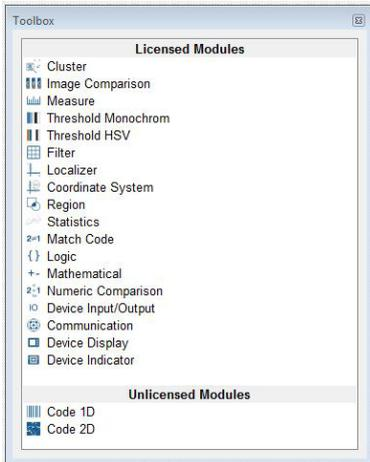

The software saves the layout of the areas.

10.2.2. The Menu Bar

The following actions are available in the menu bar.

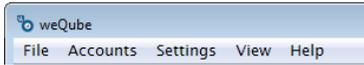

10.2.2.1. File

New ...	A new project is opened.
Open...	A saved project, a Teach+ file or a template file can be opened. Note: If a connection has been established with the sensor and you click the “Open” button, all files saved to the micro SD card are displayed. As a standard feature, template files are located here which make it possible for you to set up your applications quickly (see section 10.1.2.3).
Save	The currently open project is saved.
Save as	The currently open project can be saved to any desired folder by use of a new name.
Recent project	The most recently accessed projects are displayed and can be opened.
Close project	The currently open project is closed.
Exit	The program is exited.

10.2.2.2. User accounts

Various settings can be selected for user administration.

Log out	Logs the active user out.
Disable monitor screen	The monitor screen is disabled. The software can only be enabled again with the user password.
Settings	Further information on settings is included throughout this section.
Automatic login	If this function has been activated, the last active user account is logged in again.

After clicking the “Settings” menu, an overview of existing users appears:



The following user account is included as a standard feature after installation:

User name: admin

Password: admin

Click the "Add" button in order to set up a new user account.

If several user accounts are set up, wenglor recommends changing the password for the user name "admin".

If the administrator password is lost, please contact wenglor's support department.

A new user account can be set up in the following window. The password must have a length at least 5 characters.

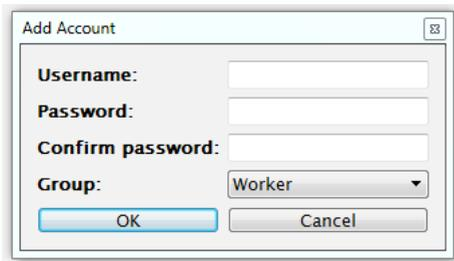

The user can be assigned to one of the following groups:

	Operator	Set-up	Admin
Load project	×	×	×
Edit/save projects		×	×
Start projects	×	×	×
Set up a new project		×	×
Teach+ playback	×	×	×
Teach+ recording		×	×
Change user account	×	×	×
Manage user account			×
Disable software		×	×
Manual trigger		×	×
Software – extended mode		×	×
Change basic sensor settings			×
Upgrade licenses			×
Change software language		×	×
Change basic software settings			×
Firmware update			×
File manager		×	×

10.2.2.3. Settings

Options:

Further settings can be selected under options.

Projects:

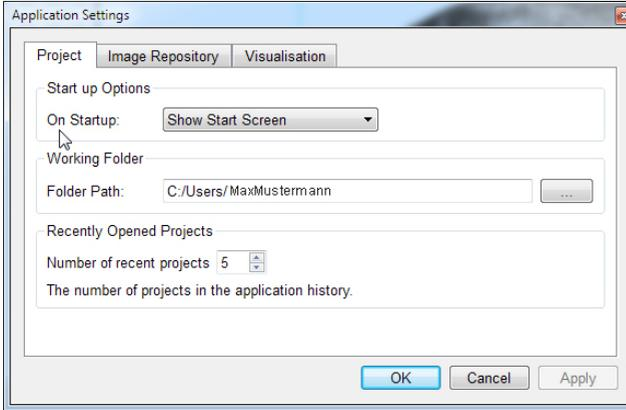

Selection of options for program initialization:

- Show initial window
- Open last project
- Open a certain project
- Connect to a certain device

Work folder:

A work folder can be selected. This folder is automatically suggested as a directory path when opening and saving images.

Recently opened projects:

The number of recently opened projects can be saved. These can be displayed by clicking **Recent projects** in the **File** menu.

Image archive:

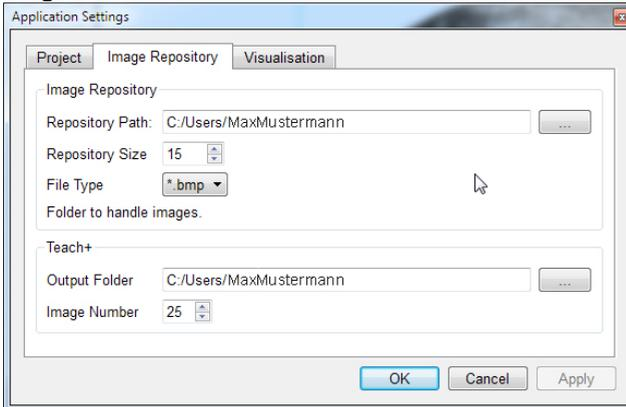

The directory path for the image archive can be selected, as well as the number of images and the image format (*.bmp or *.png).

The directory path and the number of images to be recorded are selected for the Teach+ function.

Visualization:

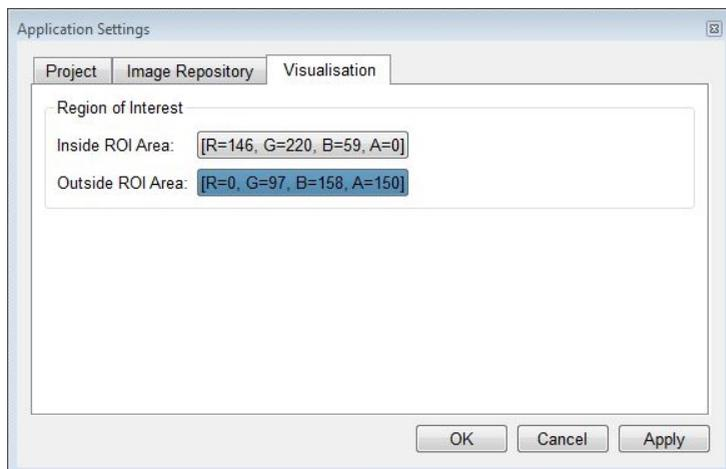

In the ROI

Select color for the area within the region of interest (active area)

Outside of the ROI

Select color for the area outside of the region of interest (inactive area)
After clicking the corresponding color preview, a window appears at which the color selection can be set.

Language:

Software language selection. Project relevant texts such as properties and values are displayed in English only and are not translated.

10.2.2.4. View

Various windows can be activated or deactivated in the “View” menu.

Note: Detailed information regarding the individual areas is included in the following sections.

Image Container Viewer	Window with an overview of all recorded images
Histogram	Window for analyzing color- and gray scale values within a certain surface area
Monitoring Data from....	Window with current sensor information
Navigator	Window with an overview of the current project
Profile	Window for analyzing color- and gray scale values along a line
Process Time	Window with an overview of current processing times for the individual modules
Toolbox	List of available tools.
Device List	See section “10.2.3.6. Network Tools” on page 61

Search the Network	See section “10.1.1. Connecting the Sensor (Connect to Device)” on page 41
File Manager	See section “10.1.1.3. The File Manager” on page 44
Characteristics	See section 10.1.1.4
Log Viewer	Window with the sensor’s system messages
Project Tools	Toolbar for the entire project
Module Toolbar	Module-specific toolbar

10.2.2.5. Help

Information	Version information
Operating instructions	A solution to a specific problem can be searched for in the operating instructions. A PDF file reader is required to this end.
Licenses	Overview of current licenses for the software and the connected sensor
Firmware update	The firmware update procedure is started. A sensor must be connected.

10.2.2.6. User Mode

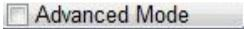

Only visible modules appear in the function tree. Modules which will not be edited can be hidden (see section “10.2.3.1. Navigation Area, Settings/Results, Function Field” on page 57).

Note: Module visibility can only be changed in the advanced mode.



All modules and settings can be edited in the navigator.

10.2.2.7. Closing the Project



The currently open project is closed.

10.2.3. Modifiable Windows and Areas

The following windows and areas can be shown or hidden.

10.2.3.1. Navigation Area, Settings/Results, Function Field

All available modules are listed in the navigation area. Additional modules can be added with the help of the “Module Toolbox” area (see section “10.2.3.5. Toolbox” on page 61). Settings and results for the selected module appear in the “Property” area. Furthermore, available functions are changed in the “Module Toolbar” according to the selected module.

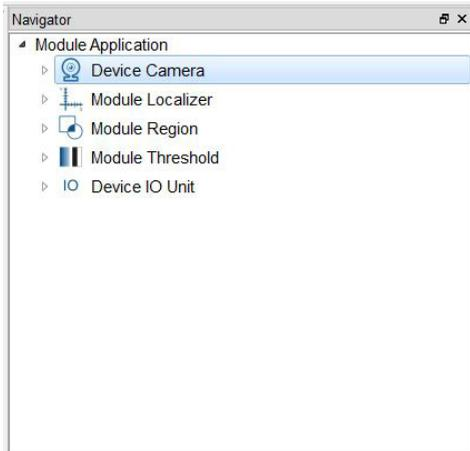

Property	Value
Process Time [ms]	0
Module State	0
Color Mode	Monochrome
Exposure Time [us]	3000
Gain	16
Subsampling	<input type="checkbox"/>
Focus Position [steps]	400
Auto Focus	<input type="checkbox"/>
Light Internal	<input checked="" type="checkbox"/>
Light External	<input type="checkbox"/>
Light Current [percent]	5
Light Mode	Flash Light
Light Segments	7
Trigger Mode	Trigger Software
Capture Timeout [ms]	1000

Various settings can be selected after right clicking a module. A module can be moved to the desired position within the project tree by clicking it and holding the mouse key depressed.

Visible The module can be made invisible for the normal mode and thus protected against any alteration of its settings.

- Not crossed out: visible in the normal mode
- Crossed out: invisible in the normal mode

The module's name can be changed.

Rename

The selected module is deleted from the function tree.

Delete

Note: Modules can be added once again with the help of the toolbox.

Copy Node Path to the Clipboard

Copying the node value to the clipboard can be helpful in making it easier to create your own LIMA commands.

Copy Module

Copies the module along with all of its settings. The position of the newly copied module can be freely selected.

10.2.3.2. Image Container Viewer

The image sequence is shown as a preview in the image container viewer, thus providing an overview of the recorded images.

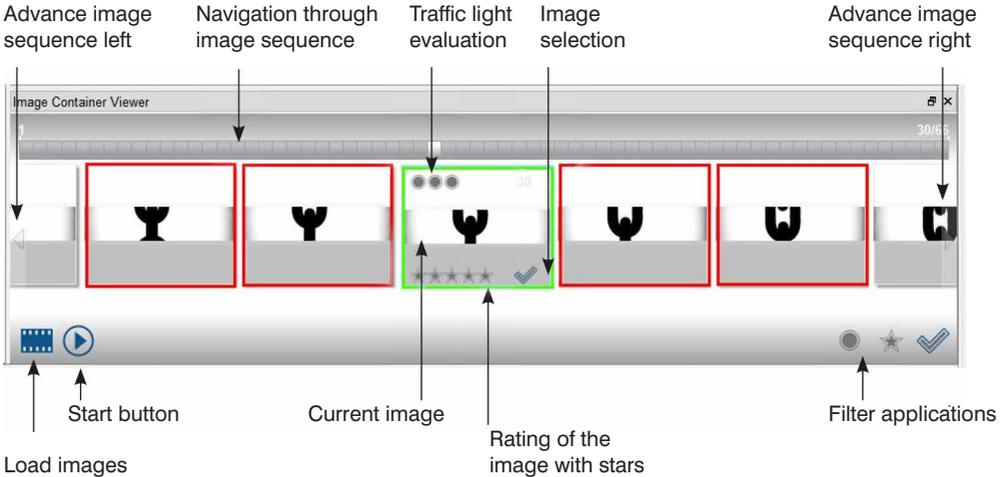

Current image	The current image is displayed in the image area and appears with a blue frame in the preview provided by the image container viewer. Evaluation is performed and the results are updated.
Start button	Starts automatic replay of the image sequence.
Advance image sequence left/right	The image to the left or right of the current image is selected and displayed in the image area.

Navigation through image sequence	This bar allows for quick navigation through the image sequence, which frequently includes a large number of images
Image selection	A certain image can be highlighted as a selected image.
Rating of the image with stars	A given number of stars can be assigned to each image in order to rate its quality.

Traffic light evaluation

Objects in the images can be evaluated with a traffic light system. For example:

- Red The object has not been detected or is not present.
- Yellow The object has been detected and is defective.
- Green The object has been reliably detected and fulfills the specified requirements.

Filter applications

Various filters can be applied to the image sequence in the image container viewer.

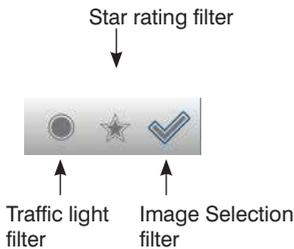

Traffic light filter

This filter can be set to a certain traffic light color, after which only accordingly evaluated images are displayed.

Star rating filter

The star rating filter for a specific number of stars only displays images with the specified star rating.

Image selection filter

Only the correspondingly selected images are displayed when this filter is used. Evaluation is performed for the respectively visible image.

Note: The three filter types can be combined as desired.

10.2.3.3. Profile

The profile area indicates the gray-scale values along an arrow within the image area. The gray-scale value for entirely black objects is 0, and for entirely white objects it's 255.



An arrow can be defined in the region of interest for the profile area. It's length and direction can be freely selected. The length of the arrow is depicted in the profile area along the X-axis. A gray-scale value within a range of 0 to 255 is assigned to each point within the arrow along the Y-axis, where 0 corresponds to black and 255 to white. This support system simplifies the processing of transitions.

Note: With threshold analysis, the gray-scale values at both sides of edges can be analyzed with the help of the profile area, making it easier to adapt entry of the threshold values (see sections 11.7 and 11.8)

10.2.3.4. Histogram

The histogram area indicates frequency distribution of the gray-scale values of a given surface in the region of interest.

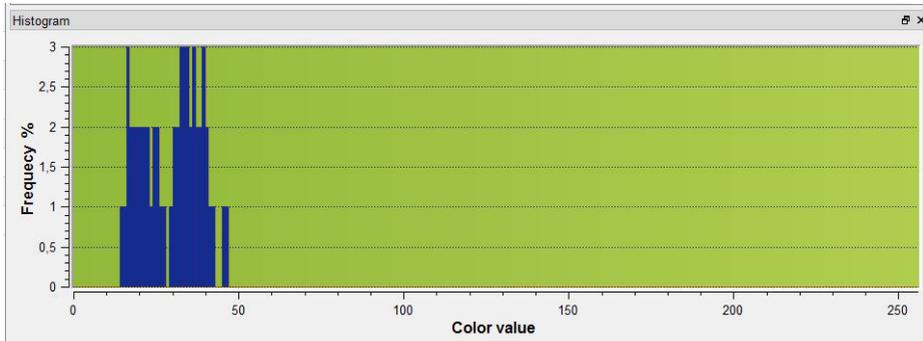

Similar to the profile area, the area to be examined must first be specified in the region of interest. This is a rectangle in the case of the histogram, whose size and position can be changed as desired. All gray-scale values from 0 to 255 appear along the X-axis. Along the Y-axis, a frequency value is assigned to each gray-scale value for the selected area. And thus the number on the Y-axis indicates the number of pixels for the corresponding gray-scale value.

10.2.3.5. Toolbox

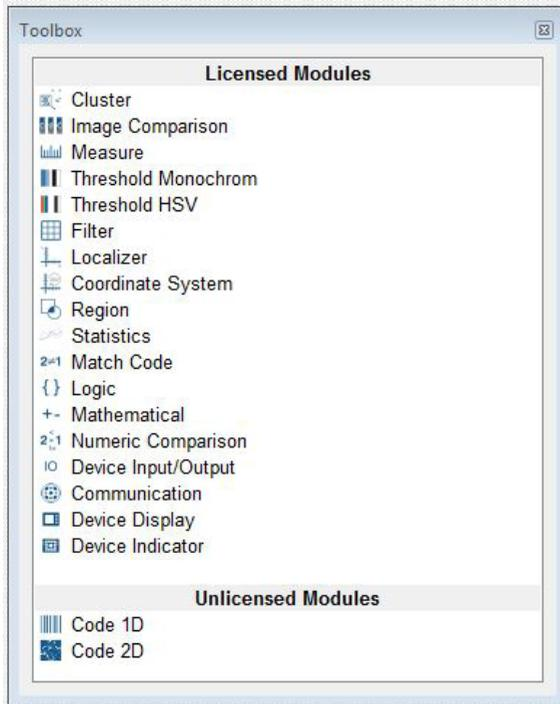

Figure: Toolbox Display Area

All modules are displayed in the **Toolbox** area which can be accessed by clicking **Toolbox** in the **View** menu. Differentiation is made between licensed and unlicensed modules. Licensed modules can be added to the project / inspection program by means of drag and drop, or by double clicking the respective module.

10.2.3.6. Network Tools

Various windows can be accessed from the "Network Tools" menu.

Device List	Opens the device list as described in section 10.1.1.1
Search Network	Opens the search network dialog box as described in section 10.1.1.2
File Manager	Opens the file manager as described in section 10.1.1.3
Characteristics	Opens the sensor's settings as described in section 10.1.1.4

10.2.3.7. Process Times

Process Times, which can be accessed by clicking **Process Times** in the **View** menu, displays evaluation times for the individual modules.

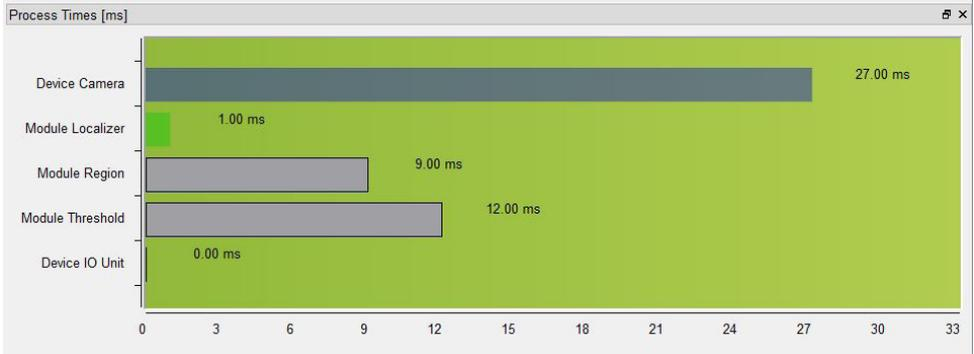

10.2.3.8. Project Tools

Project tools make it possible to execute important functions quickly.

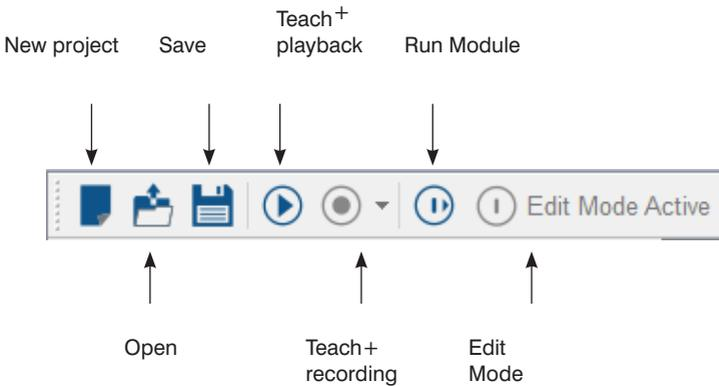

New Project	Opens a new project.
Open	<p>Opens a project, a Teach+ file or a template file.</p> <p>Note: If a connection has been established with the sensor and you click the “Open” button, all files saved to the micro SD card are displayed. As a standard feature, template files are located here which make it possible for you to set up your applications quickly (see section 10.1.2.3).</p>
Save	Saves a project file
Teach+ playback	<p>Note: Recording and playback of Teach+ files are also explained in the tutorial entitled “How to use Teach+ Files”, which is available on our website at www.wenglor.com.</p> <p>The playback function makes it possible to load and playback recorded image sequences (Teach+), including all associated project settings and interface settings. Previously recorded image sequences with the .w_r file extension can be reloaded to the system with the help of the playback function.</p> <p>A window appears at which the compressed file can be selected. The file is then decompressed at its memory location and restored to its original structure. Depending on the size of the file and the number of images it contains, decompression may take several seconds. All previously recorded images and project settings are then available.</p> <p>The images can be played back automatically as an image sequence. The corresponding icon must be clicked to this end. All stored images are then played back one after the other.</p> <p>After clicking the icon, the stored images are worked through as individual images. The playback mode can be exited by clicking the icon once again.</p>

Teach+ recording

Note: Recording and playback of Teach+ files are also explained in the tutorial entitled "How to Use Teach+ Files", which is available on our website at www.wenglor.com.

The recording function makes it possible to compress complete image sequences, along with all of the settings for the current project, into a file and save them (Teach+).

A window appears at which the memory location can be specified for the file. All files are first copied to the target directory and then a compressed archive is created. The file is automatically named. The filename consists of the term "TeachRec_" and the date and time at which the file was created. The filename consists of the current date and time, as well as the project name.

The recording function is activated by clicking the  icon. The number of images specified for the sequence is then recorded. The default value for the number of images to be recorded can be changed under options. All recorded images are then compressed, added to a single file and saved to the previously specified target directory. The target directory must be large enough to store all of the images.

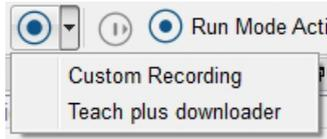

Additional recording functions appear after clicking the arrow next to the recording icon. The number of images to be recorded can be specified with the "Individual recording" function. This setting corresponds to those which can also be configured under "Options" in the "Settings" menu (see section 10.2.2.3).

If a Teach+ file has been recorded directly via the OLED display, it can be stored to the PC with the "Teach plus downloader" function..

Run Mode active

The live image from the sensor is refreshed cyclically in the operating mode. However, no changes can be made to the software settings in this mode.

Note: Compressing and transmitting the settings to the PC takes time and allows roughly 1 to 2 refresh operations per second in the software.

Edit Mode

The software settings can be changed in the edit mode. A current image is only retrieved from the sensor in the event that the module is replaced or the settings are changed.

Note: Priority is placed upon editing the settings in this mode. As a result, it's possible that trigger signals might be missed when settings and accepting parameters.

10.2.3.9. Module Tools

There are specific functions for each module which are described in the sections for each respective module.

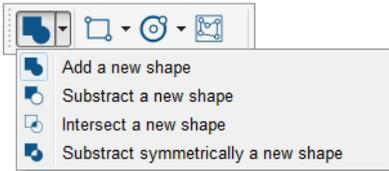
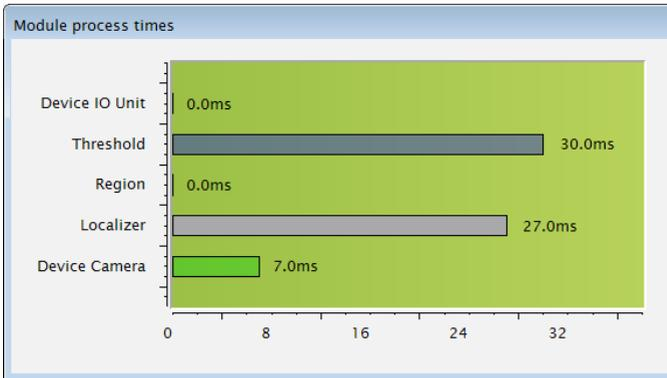

Figure: Example of a Function Window for the Region Module

Note: Not all of the modules have functions. Module tools, if any are available, only appear as long as a module is selected – otherwise they remain hidden.

10.2.3.10. Online Data Monitoring Module

There are four different windows in the Online Data Monitoring screen which include service information concerning the connected weQube.



Available/Utilized Memory

Main memory utilization for the weQube is displayed. How much memory is available for further modules is indicated here.

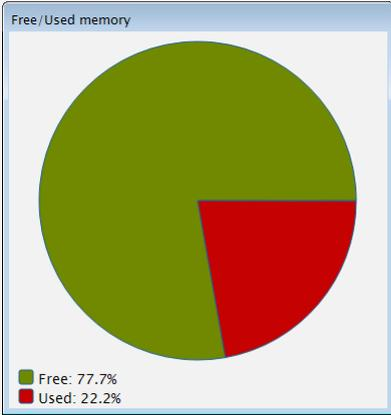

Digital I/O Status

The current status of the inputs and outputs is displayed. The display might not always be current in the case of fast applications.

The following icons can be used to select either a cascaded  or a split  view of the window.

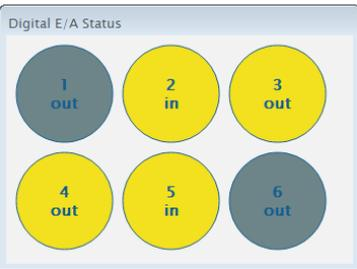

10.2.4. Image Area

A selected image is displayed in large format in the image area, for which all of the setting options can be configured.



Current sensor images as well as image files which have been stored to the PC can be displayed in the image area. The image files must have matching parameters (width, height and depth of focus). weQube software can load an image sequence by means of multiple selection. All of the following images must have the same image parameters as the first one. This makes it possible to process live images, and allows for processing of recorded sample images for the purpose of configuration. A context menu is opened by right clicking in the image area. The context menu varies depending on the image and the currently used module.

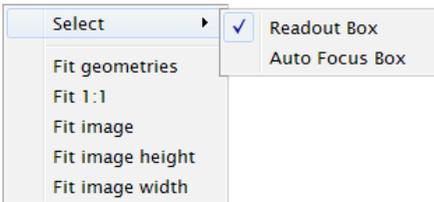

10.2.5. The Status Bar

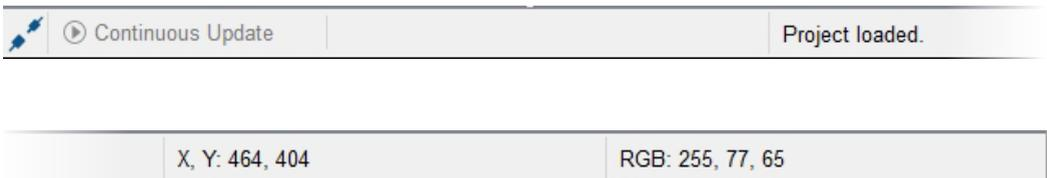

The status bar, which includes general information and image coordinates, as well as current red, yellow and blue values at the location of the mouse pointer, is located at the bottom edge of the program window.

Refreshing performance can also be influenced, i.e. whether or not camera images and parameters are cyclically taken from the sensor (run mode), or if the refresh process is suspended (edit mode). The camera image is refreshed cyclically in the run mode. No parameter changes are possible in this mode. You can switch back and forth between the two modes by simultaneously pressing the space key and the run mode / edit mode button.

Parameters can be changed in the edit mode, during which refreshing of the camera image is interrupted – camera images are not cyclically loaded from the sensor as is the case with the run mode. Each time a parameter is changed, the current camera image is loaded from the sensor.

11. Software Module

11.1. Application Module

11.1.1. Overview

Objective The uppermost level offers an overview of the project's basic characteristics.

11.1.2. Setting Parameters

Characteristics The following settings/results are displayed:

Processing Time [ms]	Sensor processing time for the entire project
Module Status	Error codes for troubleshooting support (see section 18.6).
Processing Time, Last Run [ms]	Total processing time for the last project run is displayed.
Module Status, Last Run	The module status for the last run is displayed.
Run Counter	The number of completed evaluations since the last time power was switched on is displayed.
Available Memory [kB]	Currently available capacity of the sensor's flash memory is displayed.
Filename	The filename of the currently running project is displayed.
Project Version	The version of the project is displayed. The version depends on the version of the sensor firmware with which the project was created.
Toggle Bit	The value of this bit changes for each run from 0 to 1 and vice versa.
Author	The author of the project can be specified.
Info	An additional information text can be entered for a more accurate project description.

11.2. Camera Device Module

11.2.1. Overview

Objective	Set up the camera for optimized preparation of image processing. Load stored images for subsequent image processing.
Prerequisites	<ol style="list-style-type: none"> 1. Sensor is correctly connected (see section 5.5) 2. Connection has been established from the sensor to the software (see section 10.1.1)
Procedure	<p>Various image recording settings can be changed in order to obtain the best possible camera image for subsequent image processing. For example focal point, exposure time and illumination can be adapted to the respective ambient conditions.</p> <p>Furthermore, the camera area which is read out can be reduced in size. In this way, sensor processing time can be reduced and the refresh rate can be increased.</p> <p>In addition to live images, stored images or image series can be loaded to the software in the offline mode. The camera supports a resolution of up to 736 x 480 pixels.</p>

11.2.2. Setting Parameters

Image Area	If connection to the sensor has been established, the live image is displayed in the image area. If no connection has been established, the initial window appears in the image area.
Blue Gain	The image's blue content is changed by means of automatic white balancing of the color camera. This changed value can also be adjusted manually.
Red Gain	The image's red content is changed by means of automatic white balancing of the color camera. This changed value can also be adjusted manually.

Property The following settings/results appear:

Process Time [ms]	Sensor processing time for the process steps in the device camera module
Module State	Error codes to give support in error diagnosis. (see section 18.5)
Capture Duration	Processing time for image recording
Queue Position	Number of images which are currently in the input buffer
Color Mode	Displays the sensor's image chip variant (color or monochrome).
Exposure Time (μ s)	<p>Exposure time is the period of time during which the CMOS sensor receives light. Exposure time can be selected within a range of 0.017 to 30 ms. It can be adjusted in steps of 0.001 ms.</p> <p>Short exposure times are used for dynamic processes in order to avoid motion blur.</p> <p>Long exposure times are used for static processes.</p> <ul style="list-style-type: none"> • Short exposure times are used for dynamic processes in order to avoid motion blur. • Long exposure times are used for static processes. <p>Note: Long exposure times (>1 ms) reduce light current serves as a safety mechanism and prevents overloading of the LEDs.</p>

Property

Gain	Gain is the factor by which CMOS sensor sensitivity is increased. Please note that image interference (snow), which is associated with the CMOS sensor, is amplified as well. Gain should be set as low as possible in order to avoid unnecessary diminishing of the quality of the image.
Subsampling	In the case of subsampling, transmission of brightness information, and thus resolution of the camera image, is greatly reduced. This decreases the required amount of storage space and increases transmission speed (only available with monochrome image chip versions).
Focus Position (steps)	The focus position can be changed manually for the purpose of precision adjustment
Auto Focus	An in-focus range can be selected within the field of vision. The size and position of the rectangle for the auto-focus function can be changed in the auto-focus box sub-module (see section 11.17.2). Then activate the auto-focus check box, after which the sensor is focused automatically.
Rotate Input Image	After activation, the input image is automatically rotated 180°.
Light Internal	Internal illumination can be switched on and off. Integrated illumination is switched on by activating the Light Internal check box. The setting can also be changed externally by means of linking to another value or event (only possible in the “Flash Light” mode).
Light Mode	<p>There are two different illumination variants:</p> <p>Flash Light Illumination is only activated at the moment at which image recording takes place. The LEDs are set to maximum illumination intensity.</p> <p>Continuous Light Continuous illumination is advisable where flash illumination is considered disturbing. However, the fact that illuminance is reduced as a result, along with the sensor’s service life, should be taken into consideration.</p>

<p>Light Segments</p>	<p>If reflection or a shadow impairs the image, individual LEDs can be switched off if necessary. The following table shows the assignment of numbers to active (white dot) and inactive (black dot) LEDs (front view facing the LEDs).</p> <table border="1" data-bbox="563 304 935 686"> <tr> <td data-bbox="563 304 714 400"> <p>1</p>  </td> <td data-bbox="714 304 787 400"> <p>5</p> </td> <td data-bbox="787 304 935 400">  </td> </tr> <tr> <td data-bbox="563 400 714 496"> <p>2</p>  </td> <td data-bbox="714 400 787 496"> <p>6</p> </td> <td data-bbox="787 400 935 496">  </td> </tr> <tr> <td data-bbox="563 496 714 592"> <p>3</p>  </td> <td data-bbox="714 496 787 592"> <p>7</p> </td> <td data-bbox="787 496 935 592">  </td> </tr> <tr> <td data-bbox="563 592 714 687"> <p>4</p>  </td> <td data-bbox="714 592 1084 687"></td> <td data-bbox="787 592 935 687"></td> </tr> </table>	<p>1</p> 	<p>5</p>		<p>2</p> 	<p>6</p>		<p>3</p> 	<p>7</p>		<p>4</p> 		
<p>1</p> 	<p>5</p>												
<p>2</p> 	<p>6</p>												
<p>3</p> 	<p>7</p>												
<p>4</p> 													
<p>Trigger Mode</p>	<p>Selection can be made between three different trigger variants.</p> <table border="0" data-bbox="490 778 1078 1112"> <tr> <td data-bbox="490 778 669 858"> <p>Continuous</p> </td> <td data-bbox="692 778 1078 858"> <p>Images are recorded and evaluated continuously and as quickly as possible.</p> </td> </tr> <tr> <td data-bbox="490 866 669 1026"> <p>Trigger</p> </td> <td data-bbox="692 866 1078 1026"> <p>Trigger pulses are generated by the application with the help of a trigger input. One input has to be set up as a trigger input in the digital I/O module (see section 11.21). An image can be recorded manually by pressing the "T" key.</p> </td> </tr> <tr> <td data-bbox="490 1034 669 1112"> <p>Stop</p> </td> <td data-bbox="692 1034 1078 1112"> <p>Only one trigger pulse is processed, after which all following trigger pulses are ignored.</p> </td> </tr> </table>	<p>Continuous</p>	<p>Images are recorded and evaluated continuously and as quickly as possible.</p>	<p>Trigger</p>	<p>Trigger pulses are generated by the application with the help of a trigger input. One input has to be set up as a trigger input in the digital I/O module (see section 11.21). An image can be recorded manually by pressing the "T" key.</p>	<p>Stop</p>	<p>Only one trigger pulse is processed, after which all following trigger pulses are ignored.</p>						
<p>Continuous</p>	<p>Images are recorded and evaluated continuously and as quickly as possible.</p>												
<p>Trigger</p>	<p>Trigger pulses are generated by the application with the help of a trigger input. One input has to be set up as a trigger input in the digital I/O module (see section 11.21). An image can be recorded manually by pressing the "T" key.</p>												
<p>Stop</p>	<p>Only one trigger pulse is processed, after which all following trigger pulses are ignored.</p>												

Trigger Continuous:

Sequence in Live Mode

Trigger Delay = 0
 Output Hold Time = 0
 Event 1 Delay = 0

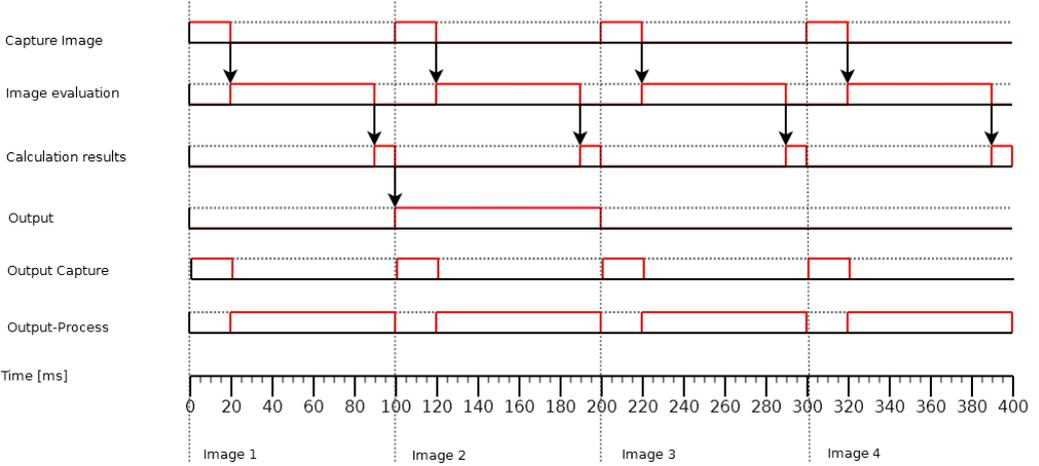

Trigger:

Sequence in Trigger mode

Trigger Delay = 0
 Output Hold Time = 0
 Event 1 Delay = 0

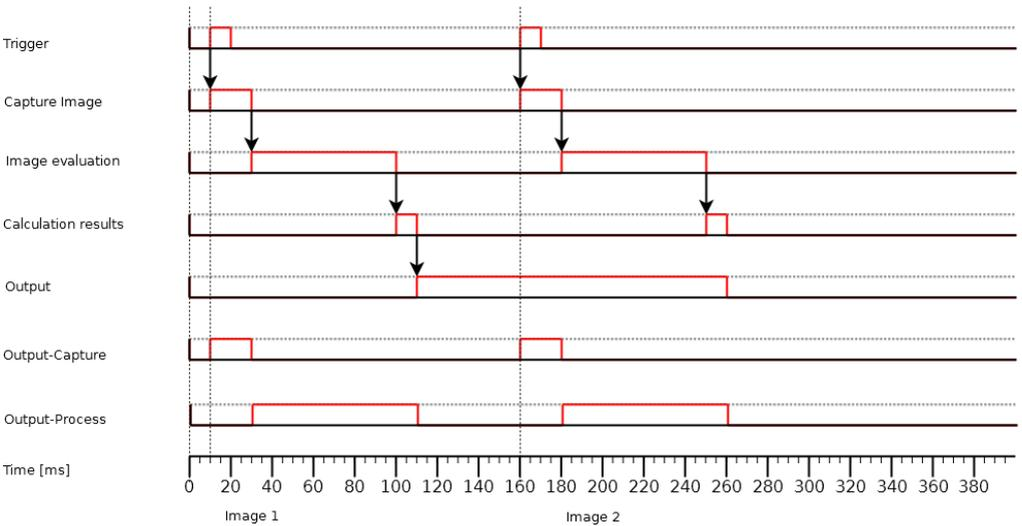

Function Field

Stored images can be loaded to projects without any connection to the sensor.

	Load stored images to the software. The image container appears. Several images can be selected at once by pressing and holding the CTRL key. Note: Image sizes of up to 736 x 480 pixels can be loaded to the software.
---	--

11.2.2.1. White Balancing



Activating White Balancing

Procedure:

The view is changed to the module's input image when the "White Balancing" tool is activated. After clicking the place in the image which should be defined as "white" in the application, the algorithm ascertains the image coordinates, from which it calculates the new "white value". The algorithm calculates the new values for the image's red and blue content. The image is then redisplayed with the changed values.

Note: The white balancing function is only available with color versions of the weQube.

11.2.3. Configuration

The device camera module includes the following configuration options:

- Image Sensor
- Readout Box
- Auto Focus Box

11.2.3.1. Image Sensor

Objective Sensor image details can be displayed.

Property The following settings/results are displayed:

Image Type	Display of the image type
X (px)	Coordinate of the sensor image coordinate system (see section 18.3)
Y (px)	
Width (px)	Width of the sensor image
Height (px)	Height of the sensor image

The following settings/results are displayed under raw 8-bit:

Size	Number of pixels read out
Bits per pixel	Display of the number of bits required to transmit one pixel
Channel Type	Various channels can be used depending on the image chip variant and the selected settings.

11.2.3.2. Readout Box Sub-Module

Objective The camera range which should actually be read out can be selected. With the help of a smaller readout box, transmission time is **reduced** and the refresh rate is **increased**.

Note: The area to be examined must lie completely within the readout box.

Image Area As a default feature, the readout box encompasses the entire camera image. It appears in the image area as a dashed frame, where it can be adjusted.

Property Readout box settings are also displayed in the settings/results area.

Width	Width of the readout box
Height	Height of the readout box

The following settings/results are displayed under origin:

X (px)	Coordinate of the sensor image coordinate system (see section 18.3)
Y (px)	

11.2.3.3. Auto-Focus Box

Objective

The sensor can be automatically focused to various objects. Well focused images can be recorded as a result, which make good image processing possible.

Note: After positioning the auto-focus box, automatic focusing can be executed under settings/results in the device camera module. The auto-focus check box must be activated to this end.

Image Area

The auto-focus box is displayed in the image area, where it can also be adjusted. The position and the size of the auto-focus rectangle can be varied. The area to be focused on must be contained within one working distance. It's advisable to select a high-contrast area.

Property

Focus box settings can also be changed in the settings/results area.

Width	Width of the readout box
Height	Height of the readout box

The following settings/results are displayed under origin:

X (px)	Coordinate of the sensor image coordinate system (see section 18.3)
Y (px)	

11.3. Module Localizer

11.3.1. Overview

Objective

Objects can be tracked and reliably detected. The following image processing functions are set up on the basis of this coordinate system.

The localizer module allows for translatory tracking. The coordinate system's X and Y positions are adjusted to this end, but **not** its rotary position.

And thus the localizer is suitable for objects for which rotary position is irrelevant. Furthermore, an easy to detect feature which stands out from the rest of the image (especially high-contrast area, special shape, edge or corner) is helpful for successful tracking.

Note: In addition to translatory tracking, rotary tracking is also possible. This can be set up in the coordinate system module (see section 11.4).

Prerequisites

1. Sensor is correctly connected (see section 5.5)
2. Connection has been established from the sensor to the software (see section 10.1.1)
3. The camera is configured / images are selected (see section 11.3)

Procedure

The module includes a movable teach box with a size of 16 x 16 pixels. This can be positioned at a reliably detectable area (especially high-contrast area, special shape, edge or corner) and taught in under settings in the localizer module. Alternatively, the location in the teach box with the highest contrast can be taught in automatically.

In every recorded image, the area within the specified search box is then detected which **most closely** corresponds to the taught in area. The **gray-scale values** in the areas serve as a basis for comparison. The coordinate system is aligned to the point of closest correspondence to the taught in area, and the object is thus translatorally tracked.

Note: No rotary tracking with rotation of the coordinate system can be executed with this model. The coordinate system module must be used in order to perform rotary tracking (see section 11.4).

11.3.2. Settings

Image Area

The coordinate system, which can be aligned to a taught in feature, is displayed. The X-axis appears red, the Y-axis green.

Settings/Results

The following settings/results appear.

Process Time	Sensor processing time for the process steps in the localizer module
Module State	Error codes to give support in error diagnosis. (see section 18.5)
Smallest Difference	The difference in the number of pixels between the previously taught in teach image and the currently found teach image is read out. The results provide an indication of the probability that the currently found reference is the correct reference.
Teach Reference Auto	A possible position (area with highest contrast) is automatically detected for the teach box within the specified search box. The coordinate system for tracking is aligned to this taught in box. The results may serve as a good starting value. In case the found position is not unique you should specify the reference position manually. The setting can also be changed externally by means of linking to another value or event.
Teach Reference	<p>The reference specified in the teach box for the teach window can be taught in and is then used as a reference value for all other images. The setting can also be changed externally by means of linking to another value or event.</p> <p>The coordinate system for tracking is aligned to this taught in box.</p> <p>Note: The area to be taught in must be positioned at a location with as much contrast as possible in the teach box sub-module before the teaching process.</p>
Input Image	Selection of the channel for the image input

11.3.3. Configuration

The localizer module includes the following configuration options:

- Coordinate System
- Search-Box.
- Teach Image
- Teach-Box.

11.3.3.1. Coordinate System

Objective Details regarding the calculated output coordinate system can be displayed in the sub-module. Input coordinate systems in the project tree can be linked against this output coordinate system for tracking purpose.

Property The following settings/results are displayed:

Phi (degrees)	Rotation of the coordinate system in degrees
---------------	--

The following settings/results are displayed under origin:

X (px)	Coordinate of the sensor image coordinate system (see section 18.3)
Y (px)	

11.3.3.2. Search Box

Objective The area can be specified within which closest correspondence to the taught in area should be detected. This area should include all possible positions of the feature to be detected (especially high-contrast area, special shape, edge or corner), in order to assure correct alignment.

Comparison with the taught in box is only conducted within the search area. A smaller search box results in less processing time and a higher refresh rate. In addition to this, a clearly delimited area increases process stability, because small, clearly defined areas are less susceptible to interference.

Image Area As a standard feature, the teach box with a size of 16×16 pixels is displayed at the upper left-hand edge of the image in the image area. The teach box can be enlarged to 96×96 pixels. Processing time required by the module increases along with the size of the teach box. Its position within the image area can be freely varied. The teach box is then taught-in in the localizer module (see section 11.3.2).

Property The following settings/results are displayed:

Width	Width of the search box along the X-axis.
Height	Height of the search box along the Y-axis.

The following settings/results are displayed under origin:

X (px)	Coordinate of the sensor image coordinate system (see section 18.3)
Y (px)	

11.3.3.3. Teach Image

Objective

The last taught in teach box is displayed in the upper left-hand corner. It's used as a reference value for future search operations.

Property

The following settings/results are displayed under origin:

Image Type	Display of the image type
X (px)	Coordinate of the sensor image coordinate system (see section 18.3)
Y (px)	
Width (px)	Width of the teach image
Height (px)	Height of the teach image

The following settings/results are displayed under raw 8-bit:

Size	Number of pixels read out
Bits per Pixel	Display of the number of bits required to transmit one pixel
Channel Type	Type of the image channel"

11.3.3.4. Teach Box

Objective

A reliably detectable area (especially high-contrast area, special shape, edge or corner) with a size of 16 x 16 pixels can be specified within the image area and then taught in to the settings for the localizer module. This taught in area serves as a reference value. Detection of closest correspondence to this taught in area is then detected in the search area of every image.

Image Area

As a standard feature, the teach box with a size of 16 x 16 pixels is displayed at the upper left-hand edge of the image in the image area. Its position within the image area can be freely varied. The teach box is then taught in to the localizer module (see section 11.3.2).

Property

The following settings/results are displayed:

Width	Width of the search box along the X-axis
Height	Height of the search box along the Y-axis

The following settings/results are displayed under origin:

X (px)	Coordinate of the sensor image coordinate system (see section 18.3)
Y (px)	

11.4. Module Coordinate System

11.4.1. Overview

Objective Objects can be tracked and reliably detected. Further image processing can be set up on the basis of this coordinate system.

The coordinate system module allows for translatory and rotary tracking. The coordinate system's X and Y positions, as well as its, are adjusted to this end.

The coordinate system is suitable for tracking objects whose rotary position can change.

Note: In addition to rotary tracking, translatory tracking is also possible. Pure translatory tracking is possible with the localizer module (see section 11.10.2).

Prerequisites

1. Sensor is correctly connected (see section 5.5)
2. Connection has been established from the sensor to the software (see section 10.1.1)
3. The camera is configured / images are selected (see section 11.2)

Abbreviated Procedure First of all, how the coordinate system is laid out can be individually specified. Various algorithms are available.

Edge transitions along search rays can then be detected with the help of search lines. A point is generated at the edge on this search line, which can be defined as an origin or a point along the X or the Y-axis.

11.4.2. Settings

Image Area

The coordinate system set up by means of the specified method is displayed.

Property

The following settings/results appear.

Process Time	Sensor processing time for the process steps in the localizer module									
Module State	Error codes to give support in error diagnosis. (see section 18.5)									
Input Image	Selection of the channel for the image input									
Construction Method	<p>The coordinate system can be set up in different ways:</p> <table> <tr> <td>1 point origin</td> <td>One point defines the origin of the translatory/rotary coordinate system.</td> </tr> <tr> <td>1 point X-axis, 1 point Y-axis</td> <td>One point defines the X-axis and one defines the Y-axis, by means of which a translatory coordinate system is created.</td> </tr> <tr> <td>1 point origin, 1 point X-axis</td> <td>One point defines the origin and one point defines the X-axis of the translatory/rotary coordinate system</td> </tr> <tr> <td>2 points X-axis, 1 point Y-axis</td> <td>Two points define the X-axis and one point defines the Y-axis of the translatory/rotary coordinate system</td> </tr> </table>		1 point origin	One point defines the origin of the translatory/rotary coordinate system.	1 point X-axis, 1 point Y-axis	One point defines the X-axis and one defines the Y-axis, by means of which a translatory coordinate system is created.	1 point origin, 1 point X-axis	One point defines the origin and one point defines the X-axis of the translatory/rotary coordinate system	2 points X-axis, 1 point Y-axis	Two points define the X-axis and one point defines the Y-axis of the translatory/rotary coordinate system
1 point origin	One point defines the origin of the translatory/rotary coordinate system.									
1 point X-axis, 1 point Y-axis	One point defines the X-axis and one defines the Y-axis, by means of which a translatory coordinate system is created.									
1 point origin, 1 point X-axis	One point defines the origin and one point defines the X-axis of the translatory/rotary coordinate system									
2 points X-axis, 1 point Y-axis	Two points define the X-axis and one point defines the Y-axis of the translatory/rotary coordinate system									
Tracking Method	<p>The way in which the points should be tracked can be specified.</p> <table> <tr> <td>No</td> <td>The points are not tracked.</td> </tr> <tr> <td>Yes</td> <td>The points are tracked in the X and Y directions.</td> </tr> <tr> <td>Horizontally</td> <td>The points are only tracked in the X direction.</td> </tr> <tr> <td>Vertically</td> <td>The points are only tracked in the Y direction.</td> </tr> </table> <p>Tracking Point: Only available if the Construction Method uses more than one point. 1. Pt.: Tracking of all points related to this point 1. 2. Pt.: Tracking of all points related to this point 2. 3. Pt. (if available): Tracking of all points related to this point 3."</p>		No	The points are not tracked.	Yes	The points are tracked in the X and Y directions.	Horizontally	The points are only tracked in the X direction.	Vertically	The points are only tracked in the Y direction.
No	The points are not tracked.									
Yes	The points are tracked in the X and Y directions.									
Horizontally	The points are only tracked in the X direction.									
Vertically	The points are only tracked in the Y direction.									

11.4.3. Configuration

The coordinate system module includes the following configuration options:

- Coordinate System
- Construction Method

11.4.3.1. Coordinate System

Objective Details regarding the calculated output coordinate system can be displayed in the sub-module. Input coordinate systems in the project tree can be linked against this output coordinate system for tracking purpose.

Property The following settings/results are displayed under origin:

Phi (degrees)	Rotation of the coordinate system in degrees
X (px)	Coordinate of the sensor image coordinate system (see section 18.3)
Y (px)	

11.4.3.2. Construction Method

Objective Specify a point for setting up the X or Y-axis within the image. Various algorithms are available.

Image Area Depending on the construction method, either a fixed point or a search ray is displayed in the image area. In the case of the search ray, the detected point appears purple.

Property

The following settings/results appear – 1 to 3 points can appear depending on the previously selected construction method.

<p>Algorithm Point 1</p>	<p>Selection for the construction method:</p> <p>Fix A fixed point is specified as point 1.</p> <p>Edge on Line An edge transition is looked for along a search line. The detected point is specified as point 1.</p> <p>Point (fixed or linked) A fixed point is specified as point 1. It's also possible to use a result point from another module as a coordinate point.</p> <p>Edge on Line An edge transition is looked for along a search line. The detected point is specified as point 1.</p> <p>Edge on Arc An edge transition is looked for on an arc. The detected point is specified as point 1.</p> <p>Segment on Line Segments are looked for along a line. The center of either the largest or the smallest segment can be specified as point 1.</p> <p>Segment on Arc Segments are looked for on an arc. The center of either the largest or the smallest segment can be specified as point 1.</p> <p>Segment on Circle Segments are looked for on a circle. The center of either the largest or the smallest segment can be specified as point 1.</p>
<p>Algorithm Point 2</p>	<p>Selection for the construction method:</p> <p>Fix A fixed point is specified as point 2.</p> <p>Edge on Line An edge transition is looked for along a search line. The detected point is specified as point 2.</p> <p>Point (fixed or linked) A fixed point is specified as point 1. It's also possible to use a result point from another module as a coordinate point.</p> <p>Edge on Line An edge transition is looked for along a search line. The detected point is specified as point 1.</p> <p>Edge on Arc An edge transition is looked for on an arc. The detected point is specified as point 1.</p> <p>Segment on Line Segments are looked for along a line. The center of either the largest or the smallest segment can be specified as point 1.</p> <p>Segment on Arc Segments are looked for on an arc. The center of either the largest or the smallest segment can be specified as point 1.</p> <p>Segment on Circle Segments are looked for on a circle. The center of either the largest or the smallest segment can be specified as point 1.</p>

Algorithm Point 3	<p data-bbox="381 172 748 196">Selection for the construction method:</p> <p data-bbox="381 225 1072 248">Fix A fixed point is specified as point 3.</p> <p data-bbox="381 248 1072 300">Edge on Line An edge transition is looked for along a search line. The detected point is specified as point 3.</p> <p data-bbox="381 300 1072 376">Point (fixed or linked) A fixed point is specified as point 1. It's also possible to use a result point from another module as a coordinate point.</p> <p data-bbox="381 376 1072 427">Edge on Line An edge transition is looked for along a search line. The detected point is specified as point 1.</p> <p data-bbox="381 427 1072 478">Edge on Arc An edge transition is looked for on an arc. The detected point is specified as point 1.</p> <p data-bbox="381 478 1072 555">Segment on Line Segments are looked for along a line. The center of either the largest or the smallest segment can be specified as point 1.</p> <p data-bbox="381 555 1072 632">Segment on Arc Segments are looked for on an arc. The center of either the largest or the smallest segment can be specified as point 1.</p> <p data-bbox="381 632 1072 707">Segment on Circle Segments are looked for on a circle. The center of either the largest or the smallest segment can be specified as point 1.</p>
-------------------	--

Construction Method

Edge on Line

First of all, the search line's gray-scale values are determined. Then a derivative is generated from the gray-scale values in order to ascertain where an edge is located. If several edges are found, polarity and the "find by" specification determine which edge will be used as a point for the coordinate system.

Example: The first transition from dark to bright should be detected as an edge in the following image.

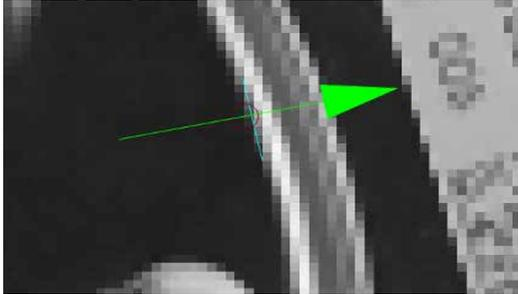

The search line's gray-scale values are represented in the profile.

The search line's gray-scale values are represented in the profile.

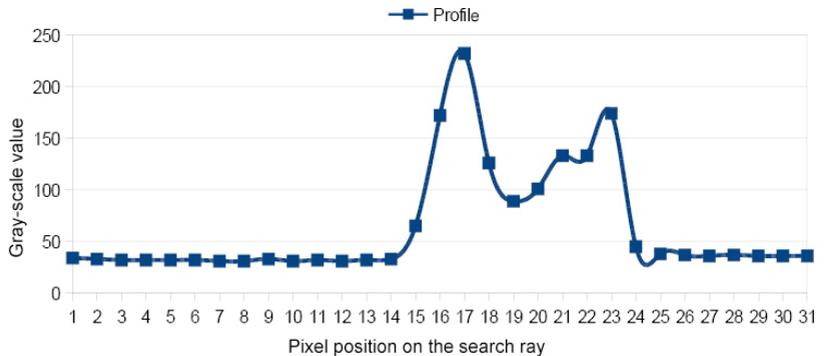

The profile's derivatives are shown in this diagram for edge widths of both 3 and 9. If the positive threshold gradient is 150 and the negative threshold gradient is -120, edges are detected close to the pixels 16, 18 and 24 (if an edge width of 3 has been selected), because the derivative exceeds the positive threshold gradient and or lies below the negative threshold gradient at these points. In contrast, no edges would be detected with an edge width of 9.



By using First Score as a setting for Find by and using Dark to Bright as a setting for Edge Polarity, it can be assured that the first transition from dark to bright is used as a point for the coordinate system.

The setting of Edge Width dictates how long a new brightness value has to be retained in order for the transition to be recognized as an edge. In the above example, the new value is retained only briefly, which causes flattening and shifting to the left of the derivative with the larger edge width. The amount of change in brightness an edge has to demonstrate in order to be accepted can be adjusted by setting the threshold gradient values. The higher the value is, the sharper the edge has to be. In order to be able to detect unsharp edges, the absolute value have to be set accordingly low.

Edge Polarity	Expected Brightness Characteristics
Either	Both bright to dark and dark to bright transitions are searched for.
Bright to Dark	Only bright to dark transitions are searched for.
Dark to Bright	Only dark to bright transitions are searched for.

Find by	<p>This parameter can be used to specify which of the detected edges will be used on the search line.</p> <p>Best Score If several edge transitions are detected on the search line, the transition with the greatest contrast is selected.</p> <p>First Score If several edge transitions are detected on the search line, the first transition in the search direction is selected.</p> <p>Last Score If several edge transitions are detected on the search line, the last transition in the search direction is selected.</p>		
Edge Width (px)	<p>The setting Edge Width controls the sensitivity of brightness changes.</p> <p>Note:</p> <ul style="list-style-type: none"> • An Edge Width of 3 pixels represents the highest sensitivity in contrast in the image. • An Edge Width of 9 pixels smoothes the gray profile to ignore the noise. 		
Threshold Gradient Pos (GrM)	<p>Threshold Gradient Pos defines the threshold of the positive gradient.</p> <p>Note: The gradient represents the change of brightness from pixel to the next. The higher the contrast of an edge the higher the gradient.</p>		
Threshold Gradient Neg (GrM)	<p>Threshold Gradient Neg defines the threshold of the negative gradient.</p> <p>Note: The gradient represents the change of brightness from pixel to the next. The higher the contrast of an edge the higher the gradient.</p>		
Edge Point	<p>The coordinates of the detected edge transition are displayed under "Edge Point":</p>		
	<table border="1"> <tr> <td data-bbox="417 965 580 1005">X (px)</td> <td data-bbox="580 965 1093 1053" rowspan="2">Coordinate of the sensor image coordinate system (see section 18.3)</td> </tr> <tr> <td data-bbox="417 1005 580 1053">Y (px)</td> </tr> </table>	X (px)	Coordinate of the sensor image coordinate system (see section 18.3)
X (px)	Coordinate of the sensor image coordinate system (see section 18.3)		
Y (px)			
Orientation	<p>Default The edge transition search direction corresponds to the direction in which the search ray has been drawn.</p> <p>Swap The edge transition search direction is the opposite of the direction in which the search ray has been drawn.</p>		

Construction Method

Edge on Arc

The construction method is the same as for “edge on line”. The difference is the search geometry. In the case of “edge on line”, edge jumps are looked for along a line. In the case of “edge on arc”, edge jumps are looked for on an arc.

Edge Polarity	<p>Expected Brightness Characteristics</p> <p>Either Both bright to dark and dark to bright transitions are searched for.</p> <p>Bright to Dark Only bright to dark transitions are searched for.</p> <p>Dark to Bright Only dark to bright transitions are searched for.</p>
Find by	<p>This parameter can be used to specify which of the detected edges will be used on the search line.</p> <p>Best Score If several edge transitions are detected on the search line, the transition with the greatest contrast is selected.</p> <p>First Score If several edge transitions are detected on the search line, the first transition in the search direction is selected.</p> <p>Last Score If several edge transitions are detected on the search line, the last transition in the search direction is selected.</p>
Edge Width (px)	<p>“Edge width” influences detection sensitivity for brightness fluctuations. Note: An edge width of 3 pixels reacts to even the smallest contrast change in the image. An edge width of 9 pixels smooths the brightness profile over a distance of 9 pixels and ignores small irregularities.</p>
Threshold Gradient Pos (GrM)	<p>Threshold Gradient Pos specifies the positive gradient acceptance threshold.</p> <p>Note: The gradient corresponds to the change in brightness from one pixel to the next. The higher the edge’s contrast, the larger the gradient.</p>
Threshold Gradient Neg (GrM)	<p>Threshold Gradient Neg specifies the negative gradient acceptance threshold.</p> <p>Note: The gradient corresponds to the change in brightness from one pixel to the next. The higher the edge’s contrast, the larger the gradient.</p>

Edge Point	The coordinates of the detected edge transition are displayed under "Edge Point":	
	X (px)	Coordinate of the image sensor coordinate system (see section "18.3. Coordinate system" on page 198)
	Y (px)	
	The search line, with which the edge transitions can be found, is defined by means of two points which are specified with their X and Y coordinates. The following settings/results are displayed for points 1 and 2 under "Search Ray".	
X (px)	Coordinate of the image sensor coordinate system (see section "18.3. Coordinate system" on page 198)	
Y (px)		
Orientation	Default	The edge transition search direction corresponds to the direction in which the search ray has been drawn.
	Swap	The edge transition search direction is the opposite of the direction in which the search ray has been drawn.

Construction Method

Segment on Line

The construction method is the same as for "edge on line". The difference is that adjacent segments are looked for in the search geometry. The beginning or end of a segment is defined by an edge. The search for edges corresponds to the search used with the "edge on line" construction method.

Segments True Count	The number of segments detected in the search geometry is displayed. The upper and lower thresholds can be adjusted manually.
Edge Width	<p>"Edge width" influences detection sensitivity for brightness fluctuations.</p> <p>Note: An edge width of 3 pixels reacts to even the smallest contrast change in the image. An edge width of 9 pixels smooths the brightness profile over a distance of 9 pixels and ignores small irregularities.</p>
Threshold Gradient Pos (GrM)	<p>Threshold Gradient Pos specifies the positive gradient acceptance threshold.</p> <p>Note: The gradient corresponds to the change in brightness from one pixel to the next. The higher the edge's contrast, the larger the gradient.</p>

Threshold Gradient Neg (GrM)	Threshold Gradient Neg specifies the negative gradient acceptance threshold. Note: The gradient corresponds to the change in brightness from one pixel to the next. The higher the edge's contrast, the larger the gradient.	
Segments Max Count	Maximum number of segments to be expected.	
Segments Minimum Length	Minimum length of the segments	
Segments Maximum Length	Maximum length of the segments	
Sort Rule	The rule used for sorting segments can be defined.	
	Position on Search Geometry	The order in which the segments are found.
	Size	Segments are sorted by size in descending order.
Segment Brightness	Bright	Only bright objects are seen as segments.
	Dark	Only dark objects are seen as segments.
Orientation	Default	The edge transition search direction corresponds to the direction in which the search ray has been drawn.
	Swap	The edge transition search direction is the opposite of the direction in which the search ray has been drawn.

Construction Method

Segment on Arc

The construction method is the same as for “edge on line”. The difference is that adjacent segments are looked for in the search geometry. The beginning or end of a segment is defined by an edge. The search for edges corresponds to the search used with the “edge on line” construction method.

Segments True Count	The number of segments detected in the search geometry is displayed. The upper and lower thresholds can be adjusted manually.	
Edge Width	“Edge width” influences detection sensitivity for brightness fluctuations. Note: An edge width of 3 pixels reacts to even the smallest contrast change in the image. An edge width of 9 pixels smooths the brightness profile over a distance of 9 pixels and ignores small irregularities.	
Threshold Gradient Pos (GrM)	Threshold Gradient Pos specifies the positive gradient acceptance threshold. Note: The gradient corresponds to the change in brightness from one pixel to the next. The higher the edge’s contrast, the larger the gradient.	
Threshold Gradient Neg (GrM)	Threshold Gradient Neg specifies the negative gradient acceptance threshold. Note: The gradient corresponds to the change in brightness from one pixel to the next. The higher the edge’s contrast, the larger the gradient.	
Segments Max Count	Maximum number of segments to be expected.	
Segments Minimum Length	Minimum length of the segments	
Segments Maximum Length	Maximum length of the segments	
Sort Rule	Position on Search Geometry	The rule used for sorting segments can be defined. The order in which the segments are found. Segments are sorted by size in descending order.
Segment Brightness	Bright Dark	Only bright objects are seen as segments. Only dark objects are seen as segments.
Segments Max Count	Maximum number of segments to be expected in the search geometry.	
Orientation	Default Swap	The edge transition search direction corresponds to the direction in which the search ray has been drawn. The edge transition search direction is the opposite of the direction in which the search ray has been drawn.

Construction Method

Segment on Circle

The construction method is the same as for “edge on line”. The difference is that adjacent segments are looked for in the search geometry. The beginning or end of a segment is defined by an edge. The search for edges corresponds to the search used with the “edge on line” construction method.

Segments True Count	The number of segments detected in the search geometry is displayed. The upper and lower thresholds can be adjusted manually.				
Edge Width	<p>“Edge width” influences detection sensitivity for brightness fluctuations.</p> <p>Note: An edge width of 3 pixels reacts to even the smallest contrast change in the image. An edge width of 9 pixels smooths the brightness profile over a distance of 9 pixels and ignores small irregularities.</p>				
Threshold Gradient Pos (GrM)	<p>Threshold Gradient Pos specifies the positive gradient acceptance threshold.</p> <p>Note: The gradient corresponds to the change in brightness from one pixel to the next. The higher the edge’s contrast, the larger the gradient.</p>				
Threshold Gradient Neg (GrM)	<p>Threshold Gradient Neg specifies the negative gradient acceptance threshold.</p> <p>Note: The gradient corresponds to the change in brightness from one pixel to the next. The higher the edge’s contrast, the larger the gradient.</p>				
Segments Max Count	Maximum number of segments to be expected.				
Segments Minimum Length	Minimum length of the segments				
Segments Maximum Length	Maximum length of the segments				
Sort Rule	<p>The rule used for sorting segments can be defined.</p> <table border="0"> <tr> <td>Position on Search Geometry</td> <td>The order in which the segments are found relative to the zero angle.</td> </tr> <tr> <td>Size</td> <td>Segments are sorted by size in descending order.</td> </tr> </table>	Position on Search Geometry	The order in which the segments are found relative to the zero angle.	Size	Segments are sorted by size in descending order.
Position on Search Geometry	The order in which the segments are found relative to the zero angle.				
Size	Segments are sorted by size in descending order.				

Segment Brightness	Bright	Only bright objects are seen as segments.
	Dark	Only dark objects are seen as segments.
Segments Max Count	Maximum number of segments to be expected in the search geometry.	
Orientation	Default	The edge transition search direction corresponds to the direction in which the search ray has been drawn.
	Swap	The edge transition search direction is the opposite of the direction in which the search ray has been drawn.

11.5. Module Region

11.5.1. Overview

Objective

The relevant region of interest used for evaluation should be as large as necessary and as small as possible.

A small, precisely defined area results in faster evaluation and a higher refresh rate. This allows for faster application runtimes because image recording and processing are quicker. Furthermore, object or feature detection is more reliable because fewer noise pixels can occur within the evaluated area.

The object to be detected must lie fully within the selected area, because reliable object detection cannot otherwise be assured.

Prerequisites

1. Sensor is correctly connected (see section 5.5)
2. Connection has been established from the sensor to the software (see section 10.1.1)
3. The camera is configured / images are selected (see section 11.2)
4. If applicable, tracking is configured (see sections 11.3 and 11.4)

Abbreviated Procedure

Any desired area can be specified as the region of interest by adding, removing or customizing shapes. In addition to existing standard shapes, any number of various shapes can also be added and linked by means of mathematical set theories.

11.5.2. Settings

Image Area

The region of interest is highlighted green in the image area (default setting).

Property

The following settings/results appear.

Process Time [ms]	Sensor processing time for the process steps in the region module.
Module State	Error codes to give support in error diagnosis. (see section 18.5)
Input Image	Selection of the image input
Coordinate System	Selection can be made regarding how the region of interest should be tracked.

Function Field

New shapes can be added to the toolbar module.

1. Select the mathematical operation.

	Add shape	The new shape should be added to the overall shape.
	Subtract shape	The new shape should be removed to the overall shape.
	Subtract symmetric	The common area of the new shape is removed from the overall shape.
	Intersect shape	The common area of the new shape and the overall shape should be selected.

Note: The order of the shapes is dictated by the order in which they are created and cannot be subsequently changed. As a result, the overall shape of all previously existing shapes is always used for the offsetting of shapes.

2. Select a new shape.

	<p>Rectangle two points</p>	<p>A rectangle is drawn with two points. The first corner of the rectangle is specified within the image area by left clicking with the mouse. The diagonally opposite corner of the rectangle is specified with a second click.</p>
	<p>Rectangle three points</p>	<p>A rectangle is drawn with three points. The first corner of the rectangle is specified within the image area by left clicking with the mouse. The next click specifies one of the neighboring corners and the third click specifies the location of the side of the rectangle opposite the side defined by the first two clicks.</p>
 	<p>Circle two points</p> <p>Circle three points</p>	<p>A circle is drawn with two points. The first click specifies the center of the circle. The radius of the circle is specified by means of the second click.</p> <p>A circle is drawn with three points. Three points around the circumference of the circle are specified with three mouse clicks.</p>
	<p>Polygon</p>	<p>A polygon can be created with any desired number of clicks. Each click specifies one of the polygon's corners. Processing of the shape is ended by double clicking the last corner. Polygons can be specially processed within the image area. Individual points can be deleted by pressing and holding the Ctrl+Shift key and clicking the respective point with the left mouse key. A new point can be added to the polygon by pressing and holding the Alt+Shift key and left clicking at the desired side of the polygon.</p>

3. Draw a new shape within the image area as described.
Newly added shapes also appear in the list under "Set".

11.5.3. Configuration

The region module includes the following configuration options:

- Region.
- Set.

Other shapes which are added also appear in addition to the standard shape (rectangle) under “Set”.

11.5.3.1. Region

Objective

The selected region of interest can be examined.

Image Area

The output region, which can be linked as an input region in the following modules, appears white.

Property

The following settings/results for the module’s input image appear under “Image”:

Image Type	Display of the image type
X (px)	Coordinate of the sensor image coordinate system (see section 18.3)
Y (px)	
Width (px)	Image width
Height (px)	Image height

The following settings/results are displayed under mask for the input image.

Size	Number of pixels in the input image
Bits per Pixel	Display of the number of bits required to transmit one pixel
Channel Type	The mask channel type is displayed.

The bounding box is positioned such that it encloses the entire specified region. The following settings/results are displayed:

Width (px)	Width of the bounding box
Height (px)	Height of the bounding box

The following settings/results are displayed for the bounding box under origin:

X (px)	Coordinate of the sensor image coordinate system (see section 18.3)
Y (px)	

11.5.3.2. Set

Objective

All of the individual shapes used in the image area, as well as the overall shape, can be adapted to the application.

1 rectangle is available as standard features.

Note: Not only can the overall shape and the two standard shapes be edited, new shapes can also be added with the help of the toolbar module (see section 9.4.2).

Image Area

The selected shapes are displayed in the image area and can be edited there as well.

Before the respective shape can be edited, it has to be clicked in the navigator under "Set". Alternatively, the overall shape can be selected by clicking "Set".

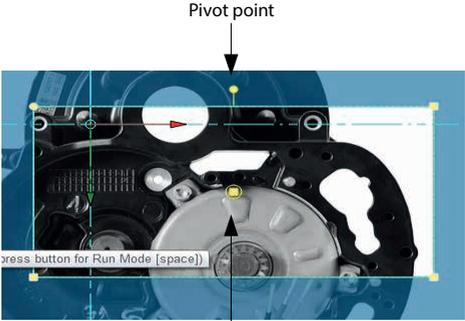
Change position	Click the respective shape in the image area and hold the mouse key depressed until the shape has been dragged to the desired position.
Change size	Click one of the corners of the respective shape in the image area. Hold the mouse key depressed until the shape reaches the desired size.
Rotate shape	<ol style="list-style-type: none"> 1. Position the pivot reference point. 2. Rotate the shape at the pivot point. 

Property

Shapes can also be edited in the settings/results field. Depending on the respective shape, a specific selection of the parameters included in the following overall list can be changed.

X-coordinate	Coordinate of the sensor image coordinate system (see section 18.3)
Y-coordinate	
Width	Width of the shape along the X-axis
Height	Height of the shape along the Y-axis
Phi	Rotation of the shape in degrees
Set operation	<p>A mathematical operation can be selected.</p> <p>Add The shape is added to the overall shape..</p> <p>Subtract The shape is removed from the overall shaped.</p> <p>Subtract Symmetric The common area of the new shape is removed from the overall shape. Note: The area which is enclosed by the new shape only is added to the overall shape.</p> <p>Intersect Only the common area shared by the respective shape and the overall shape is selected as the region of interest.</p>
Diameter	Diameter of a circle

11.6. Module Filter

11.6.1. Overview

Objective

Filters are used to highlight desired image characteristics and to suppress undesired image characteristics.

Prerequisites

1. Sensor is correctly connected (see section 5.5)
2. Connection has been established from the sensor to the software (see section 10.1.1)
3. The camera is configured / images are selected (see section 11.2)
4. If applicable, tracking is configured (see sections 11.3 and 11.4)
5. Region of interest is specified (see section 11.5)

Procedure

The desired type of filter can be selected and applied to the desired region.

11.6.2. Settings

Image Area

Current filter settings are displayed in the selected region of interest.

Property

The following settings/results appear.

Process Time [ms]	Sensor processing time for the process steps
Module State	Error codes to give support in error diagnosis. (see section 18.5)
Input Region	Selection of the region to which the filter will be applied
Input Image	Selection of the channel for the image input
Filter Type	<p>Predefined, performance-optimized filters can be selected directly. Freely definable filters have kernel sizes of 3×3 and 5×5.</p> <p>Off Input image = output image</p> <p>Sobel Edge and smoothing filters:</p> <ul style="list-style-type: none"> • Homogeneous areas appear black • Edges appear white • Edges are highlighted, even if they have relatively minimal gray-scale transitions <p>Gauss “Low-pass filter” (smaller structures are lost, larger ones are retained):</p> <ul style="list-style-type: none"> • The image becomes softer • Snow is reduced • Inhomogeneous surfaces become more homogeneous • Edges are highlighted, even if they have relatively minimal gray-scale transitions <p>Median The median is a soft-focus filter. The gray-scale value of a pixels is replaced by the median of all gray-scale values of the neighboring pixels. This is accomplished by placing all pixels in the specified surroundings in ascending order and replacing the current pixel with the mean value (the median) of the ascending sequence.</p> <ul style="list-style-type: none"> • Smoothing of the image while retaining edge steepness • Sharpness is retained because the edges do not become blurred. • Small, sporadic noise pixels are eliminated.

Filter Type

Dilatation	<p>Dilatation belongs to the morphological filter functions. These image processing functions are used to emphasize or increase objects of a specific shape and/or size</p> <ul style="list-style-type: none"> • (white portions are strengthened) • or deleted • To smooth edges • To remove errors or “noise” • To “fill up” specific segments in an image <p>Effects of a dilatation:</p> <ul style="list-style-type: none"> • Adds points to the edges of the objects according to the form and color of the neighboring point. • Small distortions and gaps are closed and disappear irrevocably. • Objects that are close to each other can be connected to each other.
Erosion	<p>Erosion belongs to the morphological filter functions. These image processing functions are used to emphasize or reduce objects of a specific shape and/or size</p> <ul style="list-style-type: none"> • (black portions are strengthened) • or deleted • To smooth edges • To remove errors or “noise” • To “fill up” specific segments in an image. <p>Effects of an erosion:</p> <ul style="list-style-type: none"> • Adds points to the edges of the objects according to the form and color of the neighboring point. • Small distortions and gaps are closed and disappear irrevocably. • Closes objects.
Opening	<p>The opening filter is the succession of an erosion and a dilatation. Erosion closes gaps of dark structures while dilatation reverses thickening of the dark objects. The increase in the surface of the dark objects that occurs in erosion is removed again through dilatation.</p> <p>Effects of the opening:</p> <ul style="list-style-type: none"> • Contours are markedly emphasized even with relatively low gray value transitions.

Filter Type

Closing Analogously to the opening filter, the closing filter is the succession of a dilatation and an erosion. Erosion closes gaps of bright structures while dilatation reverses thickening of the bright objects. The increase in the surface of the bright objects that occurs in dilatation is removed again through erosion.

Effects of the closing:

- Contours are markedly emphasized even with relatively low gray value transitions.

Sharpen The Sharpen Filter enhance the line structures or other details in an image.

Matrix Creating Your Own Filters – 3×3 or 5×5: Where filters are used, the surrounding pixels are generally analyzed for each pixel. This results in a calculated value for the respective pixel, which is used in the output image of the filter module.

The following weighting can be used with the 3×3 filter in order to create a vertical edge filter.

-1	0	1
-1	0	1
-1	0	1

The gray-scale value of the output image needs to be determined for the following central pixel. The gray-scale values of the input image's surrounding pixels are ascertained first of all to this end.

50	120	105
90	80	60
80	100	100

During calculation, each gray-scale value is multiplied by the weighting factor. The individual values are added up and then divided by 9. The result is the gray-scale value of the central pixel for the output image.

$$50 \times (-1) + 90 \times (-1) + 80 \times (-1) + 120 \times 0 + 80 \times 0 + 100 \times 0 + 105 \times 1 + 60 \times 1 + 100 \times 1 = 45$$

$$45 \div 9 = 5$$

11.6.3. Configuration

As a standard feature, the region module includes the following configuration options:

- Output Image

11.6.3.1. Output Image

Objective The filter module's output image can be linked as an input image in the following modules.

Image Area The output region, which can be linked as an input region in the following modules, appears white.

Property The following settings/results appear in the filter module's output image:

Image Type	Display of the image type
X (px)	Coordinate of the sensor image coordinate system (see section 18.3)
Y (px)	
Width (px)	Image width
Height (px)	Image height

The following settings/results are displayed under 8-bit:

Size	Number of pixels in the input image
Bit per Pixel	Display of the number of bits required for transmission
Channel Type	The binary channel type is displayed.

11.7. Module Threshold

11.7.1. Overview

Objective In order to be able to evaluate, measure or count objects, the images have to be converted to black and white binary images as a preparatory step. The objective is to separate the foreground from the background. This is the only way to assure simple subsequent evaluation of the images.

Prerequisites

1. Sensor is correctly connected (see section 5.5)
2. Connection has been established from the sensor to the software (see section 10.1.1)
3. The camera is configured / images are selected (see section 11.2)
4. If applicable, tracking is configured (see sections 11.3 and 11.4)
5. Region of interest is specified (see section 11.5)
6. If applicable, a filter is activated (see section 11.6)

Procedure The limits for the gray-scale values which will determine which pixels appear black and which appear white can be specified. The histogram and the profile which display brightness values and distribution may be helpful for the threshold value process (see sections 10.2.3.4 and 10.2.3.3).

11.7.2. Settings

Image Area

A preview of the threshold analysis appears in the image area. The threshold value process is only applied within the selected region of interest. Depending on the gray-scale values and the selected settings, the pixels in the region of interest become either black or white (white: foreground, black: background).

Property

The following settings/results appear.

Process Time [ms]	Sensor processing time for the process steps
Module State	Error codes to give support in error diagnosis. (see section 18.5)
Pixel Count	Display of the number of white pixels counted in the region of interest. The upper and lower thresholds of the pixel value can be adjusted.
Input Region	Selection of the region for the threshold process
Input Image	Selection of the image input
Teach	The current number of detected pixels (pixel count value) is taught-in. The range between minimum and maximum remains unchanged, but the minimum and maximum values of the pixel count value are adjusted such that the current number of detected pixels is half way between the two values.
Mode	<p>Threshold values can be adjusted statically or adaptively.</p> <p>Note: Threshold values can be dynamically corrected in order to compensate for minimal brightness fluctuation or different surface finishes. However, brightness differences can only be compensated for in settings which are already relatively stable by means of this adaptive adjustment.</p> <p>Static Thresholds are set to fixed values with the Threshold Low and Threshold High functions.</p> <p>Adaptive by Reference The threshold value is calculated on the basis of the mean value of the respective surface and is thus corrected. Range 1: Foreground \geq Background (foreground is brighter than background) Range 2: Foreground $<$ Background (background is brighter than foreground)</p> <p>Adaptive by Histogram The threshold values can be ideally adjusted by repositioning the arrows in the histogram, in which pixel distribution is displayed along with the corresponding gray-scale values. However, settings can also be entered manually with the help of the Offset and the Quantile 1 and 2 functions.</p>

<p>Threshold Low / Threshold High</p>	<p>The lower and upper gray-scale threshold values can be set in the static mode:</p> <p>a) The lower threshold is less than the upper threshold.</p> <ul style="list-style-type: none"> • Pixels with gray-scale values between the two thresholds appear white. • Pixels with gray-scale values which fall short of the lower threshold or exceed the upper threshold appear black. <p>b) The lower threshold is greater than the upper threshold.</p> <ul style="list-style-type: none"> • Pixels with gray-scale values between the two thresholds appear black. • Pixels with gray-scale values which fall short of the upper threshold or exceed the lower threshold appear white. <p>Note: The profile and the histogram (see sections 10.2.3.3 and 10.2.3.4), which show the gray-scale values and their distribution, simplify the specification of the lower and upper gray-scale threshold values. For example, the limit values at both sides of the edges can also be specified by means of the profile, and the thresholds can be accordingly adjusted. Histogram calculation is carried out for the entire image and is not restricted to a single region.</p>
<p>Quantile 1 / Quantile 2</p>	<p>Quantiles 1 and 2 are required for adaptive adjustment in the histogram:</p> <ul style="list-style-type: none"> • Quantile 1 specifies how many values from the gray-scale value distribution should be less than the lower gray-scale threshold value as a percentage from the bottom up. • Quantile 2 specifies how many values from the gray-scale value distribution should be greater than the upper gray-scale threshold value as a percentage from the top down.
<p>Offset</p>	<p>Offset can be adjusted by means of the adaptive setting with histogram and reference.</p> <p>With the help of the offset, the settings for the lower and upper gray-scale threshold values are shifted either up or down by an amount equal to the offset.</p>

Function Field

A window can be opened in the function field which serves as an adjustment tool for the threshold module.



Opening the adjustment tool

The gray area identifies the area for black pixels.

The red area identifies the area for white pixels.

11.7.2.1. Magic Wand

The tool “Magic Wand” is an adjustment aid for “Module Threshold” and “Module Threshold HSV”. With this tool the first settings for the threshold values can be achieved. It is possible that there will be a need to tune the threshold values afterwards.



Opening the tool

The Procedure:

While activating the tool “Magic Wand” the View changes to the linked input image. Clicking to the position in the image that is defined as foreground in the application will determine the coordinates and forward them to the algorithm. The algorithm calculates the new binarization thresholds (Threshold Low and Threshold High), and these results can be seen after.

Calculation of the threshold values:

Threshold Low = Brightness value at position of click - 20

Threshold High = Brightness value at position of click + 20

Both threshold values are limited to a range of [0...255].

Attention: The Module Threshold HSV calculates the threshold values for all three channels.

11.7.3. Configuration

As a standard feature, the threshold module includes the following configuration options:

- Output Image.

11.7.3.1. Output Image

Objective The threshold module's output image can be linked as an input image in the following modules.

Property The following settings/results appear in the filter module's output image:

Image Type	Display of the image type
X (px)	Coordinate of the sensor image coordinate system (see section 18.3)
Y (px)	
Width (px)	Image width
Height (px)	Image height

The following settings/results are displayed under binary:

Size	Number of pixels in the image
Bit per Pixel	Display of the number of bits required to transmit one pixel
Channel Type	The binary channel type is displayed.

11.8. Module Threshold HSV

11.8.1. Overview

Objective Teach in certain colors and differentiate them from other colors.

Prerequisites

1. Sensor is correctly connected (see section 5.5)
2. Connection has been established from the sensor to the software (see section 10.1.1)
3. The camera is configured / images are selected (see section 11.2)
4. If applicable, tracking is configured (see sections 11.3 and 11.4)
5. Region of interest is specified (see section 11.5)
6. If applicable, a filter is activated (see section 11.6)

Procedure A binary black and white image must be generated in order to be able to process objects. The objective is to separate the foreground from the background. Suitable parameter values are selected for the respective application to this end (hue, saturation and brightness). In order to make best possible use of options offered by the filters, a brief overview of the HSV color space is provided in the following.

A color is broken down into three channels in HSV color space.

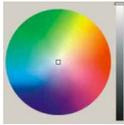

H (hue)
S (saturation)
V (brightness value)

Hue H can have a value within a range of 0° to 360°, and is generally depicted as a circle. All colors are represented within the circle. Red is at 0°, green is at 120° and blue is at 240°. All of the various hues lie between these points. Black and white are not included as hues. They are achieved by means of saturation and brightness. The circle is divided into steps of 0 to 255 for the Vision Sensor.

Saturation S is the luminosity of a given color. If saturation is set to its maximum value, a pure color appears. If saturation is set to its minimum value, a gray-scale value appears which is dependent upon the current brightness value (V). All colors between gray and the pure color can be found between these minimum and maximum values.

Brightness value V is the brightness of a color ranging from black to maximum brightness. Attainable maximum brightness is dependent upon saturation.

A color with a brightness value of 0 appears black regardless of H and S. A color with a maximum brightness value appears as the brightest variant of the respective H-S combination, regardless of its H and S values.

Example:



Advantages for Digital Image Processing

This results in a decisive advantage for digital image processing. A hue can be detected regardless of its brightness. For example, a shade of blue can be recognized independent of ambient luminosity. This is not possible in RGB color space.

Application

The setting selected at the color filter determines which colors will be allowed to pass through the filter and which will not.

If all shades of red need to be filtered out of a colorful image, the H value filter must be utilized. The filter thresholds must be set above and below the desired shade of red. All colors between the two thresholds are allowed to pass through the filter.

If all shades of red between the H thresholds should be allowed to pass through the filter for this application regardless of saturation and brightness, the S and V filters can be deactivated. However, if only the luminous shades of red should be allowed to pass through the filter, the saturation filter must be activated and all colors beginning with a given gray-scale value up to maximum saturation must be allowed to pass through. If only the dark shades of red should be allowed to pass through the filter, the brightness filter must be adjusted such that the upper threshold is set to the brightest desired value and the lower threshold to 0 (black).

The hue and saturation filters cannot be used in applications for which a gray image or a single-color imprint needs to be evaluated. An image which consists exclusively of identical hues with varying brightness values can only be analyzed with the brightness filter.

If a color image includes black, white or gray areas and certain shades of color must be permitted to pass through the filter, the saturation filter has to be used and must be set for colors with high saturation values. Black, white and gray tones do not have any defined H values, and are thus allocated a color at random. These must be sorted out by means of their characteristic saturation value ($= 0$).

Example:



If the red area in this image needs to be detected (allowed to pass through the filter), the H filter must be set so that all shades of red are allowed to pass. However, due to that fact that white areas are included (white frame) which need to be suppressed, the saturation filter must also be used.

The settings required for each individual filter are described in the following. One or more filters can be selected in order to generate the digitized black and white image.

The **histogram** and the **profile** which display brightness values and distribution may be helpful to this end (see sections 10.2.3.4 and 10.2.3.3).

11.8.2. Settings

Image Area

A preview of the HSV threshold analysis appears in the image area. The preview is for the selected region only.

Property

The following settings/results appear:

Process Time [ms]	Sensor processing time for the process steps
Module State	Error codes to give support in error diagnosis (see section 18.5)
Pixel Count	Display of the number of white pixels counted in the region of interest
Input Region	Selection of the region for the threshold process
Input Image	Selection of the channel for the image input
Teach	The currently selected settings for the HSV channels are taught in and are applied to all other images.

Function Field

A window can be opened in the function field which serves as an adjustment tool for the HSV threshold module.



Opening the adjustment tool



Opening the Magic Wand tool
(see Section 11.7.2.1)

Graphic Shifting of Thresholds

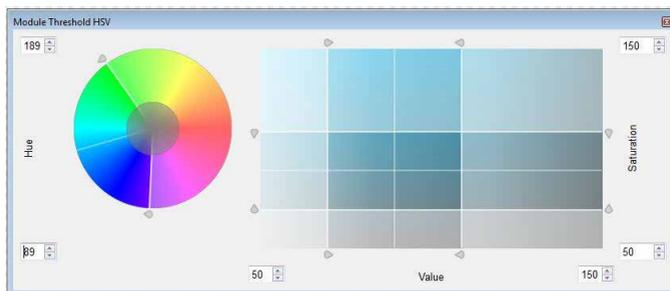

11.8.3. Configuration

The HSV threshold module includes the following configuration options:

- Output Image
- Hue
- Value
- Saturation

11.8.3.1. Output Image

Objective

The HSV threshold module's output image can be linked as an input image in the following modules.

Property

The following settings/results appear in the HSV threshold module's output image:

Image Type	Display of the image type
X (px)	Coordinate of the sensor image coordinate system (see section 18.3)
Y (px)	
Width (px)	Image width
Height (px)	Image height

The following settings/results are displayed under binary:

Size	Number of pixels in the image
Bit per Pixel	Display of the number of bits required to transmit one pixel
Channel Type	The binary channel type is displayed.

11.8.3.2. Hue

Objective

The hue filter can be adjusted.

Property

The following settings/results appear.

Active	The hue filter can be activated or deactivated.
Threshold Low	Sets the lower threshold for hue.
Threshold High	Sets the upper threshold for hue.

11.8.3.3. Value

Objective The brightness filter can be adjusted.

Property The following settings/results appear.

Active	The brightness filter can be activated or deactivated.
Threshold Low	Sets the lower threshold for brightness.
Threshold High	Sets the upper threshold for brightness.

11.8.3.4. Saturation

Objective The saturation filter can be adjusted.

Property The following settings/results appear.

Active	The saturation filter can be activated or deactivated.
Threshold Low	Sets the lower threshold for saturation.
Threshold High	Sets the upper threshold for saturation.

11.9. Module Cluster

11.9.1. Overview

Objective Detect, count or sort objects reliably in order to check for presence and correct quantity.

Prerequisites

1. Sensor is correctly connected (see section 5.5)
2. Connection has been established from the sensor to the software (see section 10.1.1)
3. The camera is configured / images are selected (see section 11.2)
4. If applicable, tracking is configured (see sections 11.3 and 11.4)
5. Region of interest is specified (see section 11.5)
6. If applicable, a filter is activated (see section 11.6)

Procedure The minimum and maximum number of neighboring pixels which make up a cluster need to be specified. It's also possible to specify the maximum number of objects to be counted, as well as the criteria according to which the objects will be sorted.

11.9.2. Settings

Image Area

Detected clusters appear in the image area with a light blue frame.

Property

The following settings/results are displayed:

Process-Time [ms]	Sensor processing time for the module
Module State	Error codes to give support in error diagnosis (see section 18.5)
Cluster True Count	The number of objects in the image area which has been detected using the corresponding settings is displayed.
Input Image	Selection of the image input
Cluster Size Min	The minimum number of adjoining white pixels can be specified, so that the respective area is counted as a cluster.
Cluster Size Max	The maximum number of adjoining white pixels can be specified, so that the respective area is still counted as a cluster.

Cluster Gap

Connected 4 Only directly adjacent white pixels (above, below to the left and to the right) are interpreted as belonging together to a single object.

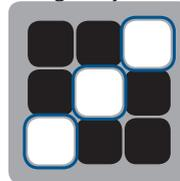

Three clusters are counted in the example.

Connected 8 Pixels joined by their corners are also interpreted as belonging together to a single object.

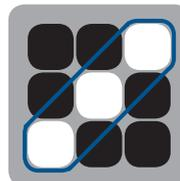

Only one cluster is counted in the example.

Cluster Max Count	The maximum number of clusters which should be counted can be specified. This size is assigned to the cluster list.								
Sort Rule	<p>The rule used for sorting clusters can be defined.</p> <table border="0" data-bbox="490 316 1057 927"> <tr> <td data-bbox="490 316 721 424">Size</td> <td data-bbox="721 316 1057 424">Detected clusters can be sorted according to size. The clusters appear in the cluster list in order of descending surface area.</td> </tr> <tr> <td data-bbox="490 469 721 600">Center of Gravity X</td> <td data-bbox="721 469 1057 600">Detected clusters are sorted according to the location of their center of gravity along the X-axis, and objects appear from left to right in the cluster list.</td> </tr> <tr> <td data-bbox="490 622 721 753">Center of Gravity Y</td> <td data-bbox="721 622 1057 753">Detected clusters are sorted according to the location of their center of gravity along the Y-axis, and objects appear from top to bottom in the cluster list.</td> </tr> <tr> <td data-bbox="490 775 721 927">Center of Gravity YX</td> <td data-bbox="721 775 1057 927">Detected clusters are sorted according to the location of their center of gravity along the X and Y-axes, and objects appear from top left to bottom right in the cluster list.</td> </tr> </table>	Size	Detected clusters can be sorted according to size. The clusters appear in the cluster list in order of descending surface area.	Center of Gravity X	Detected clusters are sorted according to the location of their center of gravity along the X-axis, and objects appear from left to right in the cluster list.	Center of Gravity Y	Detected clusters are sorted according to the location of their center of gravity along the Y-axis, and objects appear from top to bottom in the cluster list.	Center of Gravity YX	Detected clusters are sorted according to the location of their center of gravity along the X and Y-axes, and objects appear from top left to bottom right in the cluster list.
Size	Detected clusters can be sorted according to size. The clusters appear in the cluster list in order of descending surface area.								
Center of Gravity X	Detected clusters are sorted according to the location of their center of gravity along the X-axis, and objects appear from left to right in the cluster list.								
Center of Gravity Y	Detected clusters are sorted according to the location of their center of gravity along the Y-axis, and objects appear from top to bottom in the cluster list.								
Center of Gravity YX	Detected clusters are sorted according to the location of their center of gravity along the X and Y-axes, and objects appear from top left to bottom right in the cluster list.								

11.9.3. Configuration

The cluster module includes the following configuration options:

- Cluster List

11.9.3.1. Cluster List

Objective Detected clusters are listed in this sub-module in order to subsequently transmit their position, number of pixels etc. via an output.

Prerequisites The following settings/results are displayed for any selected cluster:

Pixel-Size	The number of pixels in the cluster is displayed.
------------	---

A matchbox is placed around the detected cluster. The matchbox's settings/results can be displayed.

Width (px)	Matchbox width
Height (px)	Matchbox height

The following settings/results are displayed for the matchbox under origin:

X (px)	Coordinate of the sensor image coordinate system (see section 18.3)
Y (px)	

The following settings/results are displayed under pixel size:

Pixel-Size	The number of pixels in the cluster is displayed.
------------	---

The coordinates of the cluster's center of gravity are displayed under center of gravity:

X (px)	Coordinate of the sensor image coordinate system (see section 18.3)
Y (px)	

11.10. Module Measure

11.10.1. Overview

Objective Specify and perform dimensional conformance inspections of distances, lengths, diameters or angles. Lines and circles are found with the help of search rays. Distances and angles can be measured between detected lines or points.

Image Area

1. Sensor is correctly connected (see section 5.5)
2. Connection has been established from the sensor to the software (see section 10.1.1)
3. The camera is configured / images are selected (see section 11.2)
4. If applicable, tracking is configured (see sections 11.3 and 11.4)

Abbreviated Procedure Specify dimensional inspection of position, distance, length, diameter or angle and perform measurement.

11.10.2. Settings

Property

The following settings/results appear:

Process Time [ms]	Sensor processing time for the module
Module State	Error codes to give support in error diagnosis (see section 18.5)
Input Image	Selection of the channel for the image input
Coordinate System	Selection can be made regarding how the functions should be tracked.

Function Field

	Line	A line is drawn. An edge is detected on the basis of this search line.
	Circle	A circle is drawn which is defined by means of two points. An edge is detected on the basis of this search circle.
	Circle	A circle is drawn which is defined by means of three points. An edge is detected on the basis of this search circle.
	Distance	The distance between different points or lines is calculated.
	Angle	The angle between two lines is ascertained. A line is defined by a starting point and an end point. The detected angle corresponds to the angle of intersection of the two lines in the direction towards their starting points.
	Segment on Line	A line is drawn. Segments are looked for on this line.
	Segment on Circle	A circle is drawn which is defined by means of two points. Segments are looked for on this circle.
	Segment on Arc	An arc is drawn which is defined by means of a starting point, an end point and a radius. Segments are looked for on this arc.

Set

Utilized geometric search forms such as lines and circles are listed in the Set sub-module.

11.10.2.1. Find Line

Objective Detect an edge.

Procedure First of all, activate the function in the toolbar. After the tool Find Line has been activated, a line can be defined. The first click specifies the starting point, and the second click the end point of the sought after line.

Search rays are generated perpendicular to this line. In accordance with the selected settings for edge polarity, find by and edge width, as well as positive and negative gradient threshold, an edge is searched for on each of these search rays (see section 11.4.3.1). These detected edges form a scatter plot through which only a single line is drawn, for which the clearance to the scatter plot is as small as possible. Individual points may be detected as outliers and ignored during the next iteration step (renewed best-fit calculation). This best-fit calculation is executed as many times as selected under fitting iterations.

Property The following settings/results are displayed:

Edge Polarity	<p>Expected Brightness Characteristics</p> <table border="0"> <tr> <td data-bbox="434 655 636 687">Either</td> <td data-bbox="636 655 1083 708">Both bright to dark and dark to bright transitions are searched for.</td> </tr> <tr> <td data-bbox="434 719 636 751">Bright to Dark</td> <td data-bbox="636 719 1083 772">Only bright to dark transitions are searched for.</td> </tr> <tr> <td data-bbox="434 783 636 815">Dark to Bright</td> <td data-bbox="636 783 1083 836">Only dark to bright transitions are searched for.</td> </tr> </table>	Either	Both bright to dark and dark to bright transitions are searched for.	Bright to Dark	Only bright to dark transitions are searched for.	Dark to Bright	Only dark to bright transitions are searched for.
Either	Both bright to dark and dark to bright transitions are searched for.						
Bright to Dark	Only bright to dark transitions are searched for.						
Dark to Bright	Only dark to bright transitions are searched for.						
Find by	<p>This parameter can be used to specify which of the detected edges will be used on the search line.</p> <table border="0"> <tr> <td data-bbox="434 927 636 959">Best Score</td> <td data-bbox="636 927 1083 1007">If several edge transitions are detected on the search line, the transition with the greatest contrast is selected.</td> </tr> <tr> <td data-bbox="434 1018 636 1050">First Score</td> <td data-bbox="636 1018 1083 1098">If several edge transitions are detected on the search line, the first transition in the search direction is selected.</td> </tr> <tr> <td data-bbox="434 1109 636 1141">Last Score</td> <td data-bbox="636 1109 1083 1189">If several edge transitions are detected on the search line, the last transition in the search direction is selected.</td> </tr> </table>	Best Score	If several edge transitions are detected on the search line, the transition with the greatest contrast is selected.	First Score	If several edge transitions are detected on the search line, the first transition in the search direction is selected.	Last Score	If several edge transitions are detected on the search line, the last transition in the search direction is selected.
Best Score	If several edge transitions are detected on the search line, the transition with the greatest contrast is selected.						
First Score	If several edge transitions are detected on the search line, the first transition in the search direction is selected.						
Last Score	If several edge transitions are detected on the search line, the last transition in the search direction is selected.						
Edge Width (px)	<p>The setting Edge Width controls the sensitivity of brightness changes.</p> <p>Note:</p> <ul style="list-style-type: none"> • An Edge Width of 3 pixels represents the highest sensitivity in contrast in the image. • An Edge Width of 9 pixels smoothes the gray profile to ignore the noise. 						

Property

Threshold Gradient Pos	Threshold Gradient Pos defines the threshold of the positive gradient. Note: The gradient represents the change of brightness from pixel to the next. The higher the contrast of an edge the higher the gradient.
Threshold Gradient Neg	Threshold Gradient Neg defines the threshold of the negative gradient. Note: The gradient represents the change of brightness from pixel to the next. The higher the contrast of an edge the higher the gradient.
Threshold Outlier Distance	Maximum distance to the detected shape which must be maintained by a point, in order for it to be used in the next iteration. Points which are farther away than this distance are treated as outliers.
Fitting Iterations	Number of best-fit calculations which are carried out in order that the distance of the detected points on the search lines from the line becomes as small as possible. Outliers are not used for subsequent best-fit calculations. Note: The larger the value, the more iteration steps are executed. Under certain circumstances a shape can be more closely approximated as a result, but calculation time may be increased as well.
Search Ray Length	Length of the search rays, along which an edge transition is searched for.
Search Ray Interval	Distance between the search rays, along which an edge transition is searched for. Generally speaking, the use of several search rays increases accuracy, but also requires more computing time. Note: Enlarging the interval is especially effective for faster evaluation.
Search Ray Orientation	The direction of the search ray can be turned 180° with this setting.
Point Usage [%]	The percentage indicates how many points will be used to ascertain the line.
Point Usage Strategy	The points which should be used to ascertain the line are specified. Selection can be made between the first and the last points on the search line. The search direction is made apparent by the direction of the arrow in the search geometry in the image.

The detected line, which is defined by means of two points, is listed under found geometry. The following settings/results are displayed for points 1 and 2:

X (px)	Coordinate of the sensor image coordinate system (see section 18.3)
Y (px)	

A search line is required in order to detect a line. This search geometry is also defined by means of two points.

X (px)	Coordinate of the sensor image coordinate system (see section 18.3)
Y (px)	

11.10.2.2. Find Circle

Objective Detect an edge.

Procedure After the toolbar has been activated, a circle can be drawn by means of two or three clicks.

Search rays are generated perpendicular to this circular line. In accordance with the selected settings for edge polarity, find by and edge with, as well as positive and negative gradient threshold, an edge is searched for on each of these search rays (see section 11.4.3.1). These detected edges form a scatter plot through which only a single circular line is drawn, for which the clearance to the scatter plot is as small as possible. Individual points may be detected as outliers and ignored during the next iteration step (renewed best-fit calculation). This best-fit calculation is executed as many times as selected under fitting iterations.

Property The following settings/results are displayed:

Edge Polarity	<p>Expected Brightness Characteristics</p> <p>Either Both bright to dark and dark to bright transitions are searched for.</p> <p>Bright to Dark Only bright to dark transitions are searched for.</p> <p>Dark to Bright Only dark to bright transitions are searched for.</p>
Find by	<p>This parameter can be used to specify which of the detected edges will be used on the search line.</p> <p>Best Score If several edge transitions are detected on the search line, the transition with the greatest contrast is selected.</p> <p>First Score If several edge transitions are detected on the search line, the first transition in the search direction is selected.</p> <p>Last Score If several edge transitions are detected on the search line, the last transition in the search direction is selected.</p>
Edge Width (px)	<p>The setting Edge Width controls the sensitivity of brightness changes.</p> <ul style="list-style-type: none"> • An Edge Width of 3 pixels represents the highest sensitivity in contrast in the image. • An Edge Width of 9 pixels smoothes the gray profile to ignore the noise.
Threshold Gradient Pos	<p>Threshold Gradient Pos defines the threshold of the positive gradient.</p> <p>Note: The gradient represents the change of brightness from pixel to the next. The higher the contrast of an edge the higher the gradient.</p>

Property

Threshold Gradient Neg	Threshold Gradient Neg defines the threshold of the negative gradient. Note: The gradient represents the change of brightness from pixel to the next. The higher the contrast of an edge the higher the gradient.
Threshold Outlier Distance	Maximum distance to the detected shape which must be maintained by a point, in order for it to be used in the next iteration. Points which are farther away than this distance are treated as outliers.
Fitting Iterations	Number of best-fit calculations which are carried out in order that the distance of the detected points on the search lines from the circular line becomes as small as possible. Outliers are not used for subsequent best-fit calculations. Note: The larger the value, the more iteration steps are executed. Under certain circumstances a shape can be more closely approximated as a result, but calculation time may be increased as well.
Search Ray Length	Length of the search rays, along which an edge transition is searched for.
Search Ray Interval	Distance between the search rays, along which an edge transition is searched for. Generally speaking, the use of several search rays increases accuracy, but also requires more computing time. Note: Enlarging the interval is especially effective for faster evaluation.
Search Ray Orientation	The direction of the search ray can be turned 180° with this setting.
Point Usage [%]	The percentage indicates how many points will be used to ascertain the circle.
Point Usage Strategy	The points which should be used to ascertain the circle are specified. Selection can be made between the first and the last points on the search line. The search direction is made apparent by the direction of the arrow in the search geometry in the image.

The detected circle is listed under found geometry, and is defined by means of a center and a diameter.

The following settings/results are displayed under found geometry:

Diameter (px)	The circle's diameter is displayed. The diameter tolerance can be adjusted so that the circle's diameter can be linked to an output.
---------------	--

Property

The settings/results of the detected geometry are displayed under center:

X (px)	Coordinate of the sensor image coordinate system (see section 18.3)
Y (px)	

A search circle is required in order to detect a circle. This search geometry is defined by means of a center and a diameter.

The following settings/results can be edited under search geometry:

Diameter (px)	The search circle's diameter is displayed.
---------------	--

The search circle's following settings/results can be edited under circle:

X (px)	Coordinate of the sensor image coordinate system (see section 18.3)
Y (px)	

11.10.2.3. Measure Distance

Objective

Ascertain distance between two points, or between a point and a line.

Procedure

First of all, activate the function in the toolbox.
Click the first point or line, and then click the second point or line.

Property

The following settings/results appear.

Output Distance (px)	Distance is displayed in pixels. The value can be furnished with any desired upper and lower thresholds. Click the ascertained value to this end, and then click the button. Enter the desired upper and lower threshold values to the window which then appears.				
Calculation Method	<p>The type of distance calculation to be used is specified:</p> <table border="0"> <tr> <td>Geometrical Distance</td> <td>Shortest distance between a point and a line (perpendicular)</td> </tr> <tr> <td>Center to Center</td> <td>Shortest distance between the center of two segments.</td> </tr> </table>	Geometrical Distance	Shortest distance between a point and a line (perpendicular)	Center to Center	Shortest distance between the center of two segments.
Geometrical Distance	Shortest distance between a point and a line (perpendicular)				
Center to Center	Shortest distance between the center of two segments.				

The coordinates of the detected distance are displayed under output geometry. The distance is measured between two points, which are in turn defined by their X and Y coordinates:

X (px)	Coordinate of the sensor image coordinate system (see section 18.3)
Y (px)	

11.10.2.4. Measure Intersection

Objective The angle between two lines is measured.

Procedure First of all, activate the function in the toolbox.
Click the first line, and then the second.

Property The following settings/results appear.

Output Angle (degrees)	The angle between the two lines is displayed. A line is defined by a starting point and an end point. The detected angle corresponds to the angle of intersection of the two lines in the direction towards their starting points. The value can be furnished with any desired upper and lower thresholds. Click the ascertained value to this end, and then click the button. Enter the desired upper and lower threshold values to the window which then appears.
------------------------	---

The coordinates of the detected intersection are displayed under output intersection point:

X (px)	Coordinate of the sensor image coordinate system (see section 18.3)
Y (px)	

11.10.2.5.Measure Segment on Line Sub-Module

Objective Segments are looked for along a line.

Procedure First of all, activate the function in the toolbar. After the tool has been activated, a line can be defined. The first click specifies the starting point, and the second click the end point of the sought after line.
Edges are looked for on each of these lines in accordance with the settings for edge width, positive threshold gradient, negative threshold gradient and segment brightness (see section 11.4.3.2).
The detected edges serve as starting and end points of the various segments. There are different parameters which influence the number and length of the segments to be detected.

Property The following settings/results are displayed:

Segments True Count	The number of detected segments is displayed.
Edge Width	<p>“Edge width” influences detection sensitivity for brightness fluctuations.</p> <p>Note:</p> <ul style="list-style-type: none"> • An edge width of 3 pixels reacts to even the smallest contrast change in the image. • An edge width of 9 pixels smooths the brightness profile over a distance of 9 pixels and ignores small irregularities.
Threshold Gradient Pos [GrM]	<p>Threshold Gradient Pos specifies the positive gradient acceptance threshold.</p> <p>Note: The gradient corresponds to the change in brightness from one pixel to the next. The higher the edge’s contrast, the larger the gradient.</p>
Threshold Gradient Neg [GrM]	<p>Threshold Gradient Neg specifies the negative gradient acceptance threshold.</p> <p>Note: The gradient corresponds to the change in brightness from one pixel to the next. The higher the edge’s contrast, the larger the gradient.</p>
Segments Max Count	Maximum number of segments to be expected.
Segments Minimum Length	Minimum length of the segments
Segments Maximum Length	Maximum length of the segments

Property

Sort Rule	The rule used for sorting segments can be defined.	
	Position on Search Geometry	Sorting is based on the position on the search ray. The results depend on the orientation setting.
	Size [Longest First]	Segments are sorted in descending order beginning with the longest segment.
	Size [Shortest First]	Segments are sorted in ascending order beginning with the shortest segment.
Segment Brightness	This setting specifies whether bright or dark segments will be evaluated.	
Orientation	The search direction can be turned 180° with this setting.	

11.10.2.6.Measure Segment on Circle Sub-Module

Objective

Segments are looked for on a circle.

Procedure

After the tool has been activated, a circle can be drawn by means of two clicks.

Edges are looked for on the circle in accordance with the settings for edge width, positive threshold gradient, negative threshold gradient and segment brightness (see section 11.4.3.2).

The detected edges serve as starting and end points of the various segments. There are different parameters which influence the number and length of the segments to be detected.

The following settings/results are displayed:

Segments True Count	The number of detected segments is displayed.
Edge Width	<p>“Edge width” influences detection sensitivity for brightness fluctuations.</p> <p>Note:</p> <ul style="list-style-type: none"> • An edge width of 3 pixels reacts to even the smallest contrast change in the image. • An edge width of 9 pixels smooths the brightness profile over a distance of 9 pixels and ignores small irregularities.
Threshold Gradient Pos [GrM]	<p>Threshold Gradient Pos specifies the positive gradient acceptance threshold.</p> <p>Note: The gradient corresponds to the change in brightness from one pixel to the next. The higher the edge's contrast, the larger the gradient.</p>

Property

Threshold Gradient Neg [GrM]	Threshold Gradient Neg specifies the negative gradient acceptance threshold. Note: The gradient corresponds to the change in brightness from one pixel to the next. The higher the edge's contrast, the larger the gradient.						
Segments Max Count	Maximum number of segments to be expected.						
Segments Minimum Length	Minimum length of the segments						
Segments Maximum Length	Maximum length of the segments						
Sort Rule	<p>The rule used for sorting segments can be defined.</p> <table border="0"> <tr> <td>Position on Search Geometry</td> <td>Sorting is based on the position on the search ray. The results depend on the orientation setting.</td> </tr> <tr> <td>Size [Longest First]</td> <td>Segments are sorted in descending order beginning with the longest segment.</td> </tr> <tr> <td>Size [Shortest First]</td> <td>Segments are sorted in ascending order beginning with the shortest segment.</td> </tr> </table>	Position on Search Geometry	Sorting is based on the position on the search ray. The results depend on the orientation setting.	Size [Longest First]	Segments are sorted in descending order beginning with the longest segment.	Size [Shortest First]	Segments are sorted in ascending order beginning with the shortest segment.
Position on Search Geometry	Sorting is based on the position on the search ray. The results depend on the orientation setting.						
Size [Longest First]	Segments are sorted in descending order beginning with the longest segment.						
Size [Shortest First]	Segments are sorted in ascending order beginning with the shortest segment.						
Segment Brightness	This setting specifies whether bright or dark segments will be evaluated.						
Orientation	The search direction can be turned 180° with this setting.						

11.10.2.7.Measure Segment on Arc Sub-Module

Objective

Segments are looked for on an arc.

Procedure

First of all, activate the function in the toolbar. Specify the center of the arc by clicking the desired point. The second click defines the starting angle and the third click the end angle, thus resulting in an arc.

Edges are looked for on the arc in accordance with the settings for edge width, positive threshold gradient, negative threshold gradient and segment brightness (see section 11.4.3.2).

The detected edges serve as starting and end points of the various segments. There are different parameters which influence the number and length of the segments to be detected.

Property

The following settings/results are displayed:

Segments True Count	The number of detected segments is displayed.						
Edge Width	<p>“Edge width” influences detection sensitivity for brightness fluctuations.</p> <p>Note:</p> <ul style="list-style-type: none"> • An edge width of 3 pixels reacts to even the smallest contrast change in the image. • An edge width of 9 pixels smooths the brightness profile over a distance of 9 pixels and ignores small irregularities. 						
Threshold Gradient Pos [GrM]	<p>Threshold Gradient Pos specifies the positive gradient acceptance threshold.</p> <p>Note: The gradient corresponds to the change in brightness from one pixel to the next. The higher the edge’s contrast, the larger the gradient.</p>						
Threshold Gradient Neg [GrM]	<p>Threshold Gradient Neg specifies the negative gradient acceptance threshold.</p> <p>Note: The gradient corresponds to the change in brightness from one pixel to the next. The higher the edge’s contrast, the larger the gradient.</p>						
Segments Max Count	Maximum number of segments to be expected.						
Segments Minimum Length	Minimum length of the segments						
Segments Maximum Length	Maximum length of the segments						
Sort Rule	<p>The rule used for sorting segments can be defined.</p> <table border="0"> <tr> <td>Position on Search Geometry</td> <td>Sorting is based on the position on the search ray. The results depend on the orientation setting.</td> </tr> <tr> <td>Size [Longest First]</td> <td>Segments are sorted in descending order beginning with the longest segment.</td> </tr> <tr> <td>Size [Shortest First]</td> <td>Segments are sorted in ascending order beginning with the shortest segment.</td> </tr> </table>	Position on Search Geometry	Sorting is based on the position on the search ray. The results depend on the orientation setting.	Size [Longest First]	Segments are sorted in descending order beginning with the longest segment.	Size [Shortest First]	Segments are sorted in ascending order beginning with the shortest segment.
Position on Search Geometry	Sorting is based on the position on the search ray. The results depend on the orientation setting.						
Size [Longest First]	Segments are sorted in descending order beginning with the longest segment.						
Size [Shortest First]	Segments are sorted in ascending order beginning with the shortest segment.						
Segment Brightness	This setting specifies whether bright or dark segments will be evaluated.						
Orientation	The search direction can be turned 180° with this setting.						

11.11. Module Code 1D

11.11.1. Overview

Objective All common 1D codes can be read with the 1D code module.
 The following 1D codes can be read: Code39, Code128, 2/5 Industrial, 2/5 Interleaved, Codabar, EAN-13, EAN-13 Add-On 2, EAN13 Add-On 5, EAN-8, EAN-8 Add-On 2, EAN-8 Add-On 5, UPC-A, UPC-A Add-On 2, UPC-A Add-On 5, UPC-E, UPC-E Add-On 2, UPC-E Add-On 5, Code 93, MSI, PharmaCode, RSS-14, RSS-14 Truncated, RSS-14 Stacked, RSS-14 Stacked Omnidir, RSS Limited, RSS Expanded, RSS Expanded Stacked.

Prerequisites

1. Sensor is correctly connected (see section 5.5)
2. Connection has been established from the sensor to the software (see section 10.1.1)
3. The camera is configured / images are selected (see section 11.2)

Procedure Various code settings can be entered in order to assure reliable code recognition.

11.11.2. Settings

Property The following settings/results appear.

Process Time [ms]	Sensor processing time for the process steps
Module State	Error codes to give support in error diagnosis (see section 18.5)
Reading True Count	The number of codes detected in the image.
Input Image	Selection of the channel for the image input
Code Type	The type of code can be selected: Code39, Code128, 2/5 Industrial, 2/5 Interleaved, Codabar, EAN-13, EAN-13 Add-On 2, EAN13 Add-On 5, EAN-8, EAN-8 Add-On 2, EAN-8 Add-On 5, UPC-A, UPC-A Add-On 2, UPC-A Add-On 5, UPC-E, UPC-E Add-On 2, UPC-E Add-On 5, Code 93, MSI, PharmaCode, RSS-14, RSS-14 Truncated, RSS-14 Stacked, RSS-14 Stacked Omnidir, RSS Limited, RSS Expanded, RSS Expanded Stacked
Read Timeout	The time during which the sensor attempts to read the code. If reading is not successful within this period of time, the process is aborted and the reading results are rendered invalid. Time can be set within a range of 0 to 20 seconds in steps of 1 ms. Aborting the read attempt takes about 20 ms. The module's minimum processing time is thus also 20 ms.
Reading Max Count	The maximum number of codes to be read from the image is specified.
Quality Grading	Quality grading of the code in accordance with ISO/IEC 15416 can be activated. Note: Activation of this functions increases the module's decoding time. Note: The results of the code evaluation in accordance with the standard can be found in the configuration reading list (see section "11.11.3.1. Reading List" on page 127).

11.11.3. Configuration

The 1D code module includes the following configuration options:

- Reading List
- Search Box
- Enhanced Parameter

11.11.3.1. Reading List

Property

The following settings/results are displayed:

Reading #1	Scanned Code.
Quality	<p>If quality grading according to ISO 15416 is activated, the results of quality testing are displayed at this level. The evaluation of code quality is specified as a number between 0 and 4, 0 being the worst and 4 the best evaluation.</p> <p>Overall Quality Minimum of all individual grades</p> <p>Decode Is set to 4 when the reflectance profile of the symbol could be decoded according to the reference decode algorithm for the symbology and 0, otherwise.</p> <p>Symbol Contrast "The range between the minimum and the maximum value in the reflectance profile. A strong contrast results in a good grading"</p> <p>Minimum Reflectance Is set to 4 if the lowest reflectance value in the scan reflectance profile is lower or equal to 0.5 of the maximum reflectance value. Otherwise a value of 0 is assigned</p> <p>Minimum Edge Contrast Grades the minimum of the edge contrast values measured in the reflectance profile</p> <p>Modulation Indicates how strong the amplitudes of the barcode elements are. Big amplitudes make the assignment of the elements to bars or spaces more certain, resulting in a high modulation grade</p> <p>Defects Grading of reflectance irregularities found within elements and quiet zones</p> <p>Decodability Reflects deviations of the element widths from the nominal widths defined for the corresponding symbology</p> <p>Additional Requirements Barcode symbology specific requirements: mostly regarding the required quiet zones, but sometimes it can be also related to wide/narrow ratio, inter character gaps, guarding patterns or further symbology specific characteristics</p> <p>Note: More detailed information regarding the results of quality testing can be found in the corresponding standard.</p>
Envelope	The read code surrounding polygon.

11.11.3.2. Search Box

Objective

The region of interest within codes are detected can be specified. With the help of a smaller search box, processing time is **reduced** and the refresh rate is **increased**.

Note: The area to examined must lie completely within the search box.

Image Area

By default, the search box encompasses the entire camera image. It appears in the image area as a dashed frame, where it can be adjusted.

Property

Search box settings are also displayed in the settings/results area.

Width	Width of the search box
Height	Height of the search box

The following settings/results are displayed for the search box under origin:

X (px)	Coordinate of the sensor image coordinate system (see section 18.3)
Y (px)	

11.11.3.3. Enhanced Parameter

Element Size Min	Minimum size of barcode elements, i.e. the minimum width of bars and spaces. For small barcodes, the value should be reduced to 1.5. In the case of huge barcodes, the value should be increased, which results in a shorter execution time. Typical values: [1.5...10.0] Default: 2.0
Element Size Max	Maximum size of barcode elements, i.e. the maximum width of bars and spaces. This value should be sufficiently high in order to find the complete barcode region. On the other hand the value should be adequately low such that two neighboring barcodes are not fused into a single one. Typical values: [4.0...60.0] Default: 8.0
Element Height Min	Minimum barcode height. The default value of this parameter is -1, meaning that the barcode reader automatically derives a reasonable height from the other parameters. Just for very flat and very high barcodes a manual adjustment of this parameter can be necessary. In the case of a barcode with a height of less than 16 pixels the respective height should be set by the user. Note, that the minimum value is 8 pixels. If the barcode is very high, i.e. 70 pixels and more, manually adjusting to the respective height can lead to a speedup of the subsequent finding and reading operation. Typical values: [-1, 8...64] Default: -1

Number of Scanlines	<p>Maximum number of scanlines used during the scanning of a (candidate) barcode. If 'Number of Scanlines' is not set (the parameter has a value of 0) the maximum number of scanlines is determined internally and it will be 10 for all single-row barcodes, 20 for RSS-14 Stacked Omnidirectional, respectively, and 55 for RSS Expanded Stacked. With this parameter, you can improve performance in two cases. In the first case, the image contains many false candidates. While the barcode itself is usually decoded after one or two scans (except for stacked barcodes, see below), a false candidate is scanned with the default value of 10 scanlines, which increases the runtime unnecessarily. Reducing the number of scanlines can therefore improve performance in images with many false candidates. As a rule of thumb, images with higher quality need less scanlines than images of lower quality. For an average image, a value between 2 and 5 should be sufficient. If a barcode can, however, not be detected after reducing the number of scanlines, the number has to be increased again. The second case concerns stacked barcodes (currently RSS-14 Stacked, RSS-14 Stacked Omnidirectional, and RSS Expanded Stacked). Here, all scanlines are evaluated, in contrast to single-row barcodes (e.g., Code 128, EAN 13, or RSS Limited) where the scanning stops after the code is decoded successfully. Since the scanning of the scanlines is actually one of the most time consuming parts of the barcode algorithm, adjusting 'Number of Scanlines' might result in essential performance improvements. This is especially valid for RSS Expanded Stacked. A RSS Expanded Stacked symbol might have up to 11 rows and therefore 55 scanlines are required to robustly detect all of them. If only symbols with smaller number of rows are expected, one can reduce 'Number of Scanlines' leaving 1.5 to 5 scanlines per row. Typical values: [0, 5, 10, 20...] Default: 0</p>
Min Identical Scanlines	<p>The minimum number of scanning lines which deliver the same result, which is necessary in order to accept the deciphering of a symbol. If this parameter has not been set (i.e. if it has a value of 0), the barcode is deciphered as soon as a scanning line has been successfully decoded. The probability that the barcode will be read incorrectly can be reduced with this parameter. The standard value of 0 is recommended for all barcode types except for 2/5 Industrial and 2/5 Interleaved. In the case of code types 2/5 Industrial and 2/5 Interleaved, a value of at least 2 is recommended in order to minimize incorrect reading. It's also advisable to select a value of 2 or higher in order to prevent reading barcodes inadvertently, especially when image quality is poor or the edges of the bars can't be clearly detected.</p>
Orientation	<p>Expected barcode orientation. A potential (candidate) barcode contains bars with similar orientation. The 'Orientation' and 'Orientation Tolerance' parameters are used to specify the range ['Orientation'- 'Orientation Tolerance', 'Orientation'+ 'Orientation Tolerance']. The barcode algorithm processes a candidate barcode only when the average orientation of its bars lies in this range. If the barcodes are expected to appear only in certain orientations in the processed images, one can reduce the orientation range adequately. This enables an early identification of false candidates and hence shorter execution times. This adjustment can be used for images with a lot of texture, which includes fragments tending to result in false barcode candidates. The reading direction of the barcodes is ignored, which results in relevant orientation values only in the range [-90.0...90.0]. Typical values: [-90.0...90.0]</p>

Orientation Tolerance	Orientation tolerance. Please refer to the explanation of 'Orientation' parameter for further information. As explained there, relevant orientation values are only in the range of [-90.0...90.0], which means that with 'Orientation Tolerance' = 90 the whole range is spanned. Therefore valid values for 'Orientation Tolerance' are only in the range of [0.0...90.0]. The default value 90.0 means that no restriction on the barcode candidates is performed. Typical values: [0.0...90.0] Default: 90.0
Start Stop Tolerance	Enforces a tolerant ('high') or strict ('low') searching criteria, while inspecting a scanline for a start or stop pattern, respectively. A more tolerant criteria will generally increase the detection chances of a barcode, provided that a clear symbol is imaged in the processed image. On the other side, it might result in false detections in noisy images or images containing symbols from other symbologies. Less tolerant criteria increase the robustness against false detections, but might reduce the general detection rate. Currently, there are two distinct criteria implemented only for Code 128. List of values: ['high', 'low'] Default: 'high'
Threshold	'Threshold' defines a threshold, which is a relative value with respect to the dynamic range of the scanline pixels. The barspace-sequence of a barcode is determined with a scanline measuring the position of the edges. Finding these edges requires the mentioned threshold. In the case of disturbances in the barcode region or a high noise level, the value of 'Threshold' should be increased. Typical values: [0.05...0.2] Default: 0.05
Threshold Absolute	If a scanline is laid in an image region with no or just very small gray value dynamic range (e.g., in a white region with all gray values near 255), the edge detection threshold based on 'Threshold Absolute' would be computed unreasonably small. This leads typically to the detection of a big amount of false edges. 'Threshold Absolute' is used to prevent such misdetections. If the threshold value based on 'Threshold' gets smaller than the value of 'Threshold Absolute', the latter is used as threshold instead. By default, 'Threshold Absolute' is set to 5.0. A greater value might be more appropriate for images with high noise levels. On the other hand, in noise-free images with very weak contrast, this parameter might disturb the detection of real edges, so it might be necessary to reduce it or even completely disable it by setting it to 0.0. Typical values: [0.0...10.0] Default: 5.0
Max Different Orientation	A potential barcode region contains bars, and hence edges, with a similar orientation. The value "Max Different Orientation" denotes the maximum difference in this orientation between adjacent pixels and is specified in degrees. If a barcode is of bad quality with jagged edges, the parameter "Max Different Orientation" should be set to higher values. If the barcode is of good quality "Max Different Orientation" can be set to lower values, thus reducing the number of potential but false barcode candidates. Typical values: [2...20] Default: 10
Check Character	For barcodes with a facultative check character, this parameter determines whether the check character is taken into account or not. If the barcode has a check character, 'Check Character' should be set to 'present' and thus the check character is tested. In that case, a barcode result is returned only if the check sum is correct. For 'Check Character' set to 'absent' no check sum is computed and barcode results are returned as long as they were successfully decoded. Barcodes with a facultative check character are, e.g. Code 39, Codabar, 2/5 Industrial and 2/5 Interleaved. List of values: ['absent', 'present'] Default: 'absent'

Composite Code	EAN.UPC barcodes can have an additional 2D Composite code component appended. If 'Composite Code' is set to 'CCA/B' the composite component will be found and decoded. By default, 'Composite Code' is set to 'none' and thus it is disabled. If the searched barcode symbol has no attached composite component, just the result of the barcode itself is returned. Composite codes are supported only for barcodes of the RSS family. List of values: ['none', 'CC-A/B'] Default: 'none'
UPCE Encodation	For UPC-E barcodes, different output formats can be used. By default, 'UPCE Encodation' is set to 'ucc-12' and the decoded string will be returned in UCC-12 format (consisting of 12 digits). If 'UPCE Encodation' is set to 'zero-suppressed', the result will be returned in zero-suppressed format (with suppressed zeros at defined places). This format consists of a leading zero, six encoded digits, and an implicitly encoded check digit. This corresponds to the format demanded by ISO/IEC 15420 standard. List of values: ['ucc-12', 'zero-suppressed'] Default: 'ucc-12'

11.12. Module Code 2D

11.12.1. Overview

Objective	All common 2D codes can be read with the 2D code module.
	<p>The following 2D codes can be read:</p> <ul style="list-style-type: none"> • Data Matrix ECC 200 • QR Code • PDF417
Prerequisites	<ol style="list-style-type: none"> 1. Sensor is correctly connected (see section 5.5) 2. Connection has been established from the sensor to the software (see section 10.1.1) 3. The camera is configured / images are selected (see section 11.2)
Procedure	An object with a corresponding 2D code is read.

11.12.2. Settings

Property

The following settings/results appear.

Process Time [ms]	Sensor processing time for the module
Module State	Error codes to give support in error diagnosis (see section 18.5)
Reading True Count	The number of 2D codes which have been read is displayed.
Teach	Reading of the current 2D code is adjusted to the respective conditions.
Input Image	Selection of the channel for the image input
Code Type	The type of 2D code can be selected. <ul style="list-style-type: none"> • Data Matrix ECC 200 • QR Code • PDF417
Recognition	In the case of poor code quality, it's advisable to set this parameter to enhanced or maximum. <p>Standard Easily legible 2D codes are recognized quickly and reliably in the standard mode.</p> <p>Enhanced Difficult 2D codes can be read in the enhanced mode. However, processing takes longer.</p> <p>Maximum Even partially destroyed 2D codes can be read in the maximum mode. However, this mode requires the biggest amount of processing time.</p>
Read Timeout [s]	The time during which the sensor attempts to read the code. If reading is not successful within this period of time, the process is aborted and the reading results are rendered invalid. Time can be set within a range of 0 to 20 seconds in steps of 1 ms. Aborting the reading process takes about 20 ms, and thus the module's minimum processing time is 20 ms.
Reading Max Count	The maximum number of codes to be read simultaneously can be specified. Up to 20 codes can be read during one image recording operation.
Quality Grading	Quality grading of the code can be activated. Note: Activation of this function increases the module's decoding time. <p>None No quality grading</p> <p>ISO/IEC 15415 Quality grading in accordance with ISO/IEC15415</p> <p>AIM DPM-1-2006 Quality grading in accordance with AIM DPM-1-2006 Note: Only available for ECC200 and QR Code.</p> <p>Note: The results of the code evaluation in accordance with the selected standard can be found in the configuration reading list (see section 11.4.3.1).</p>

11.12.3. Configuration

The 2D code module includes the following configuration options:

- Reading List
- Search Box
- Enhanced Parameter

11.12.3.1. Reading List Sub-Module

Property The following settings/results are displayed:

Reading #1	Reading Code.
Quality ISO/IEC 15415	<p>According to the standard the grades are whole numbers from 0 to 4, where 0 is the lowest and 4 the highest grade. It is important to note what, even though the implementation is strictly based on the standard, the computation of the print quality grades depends on the preceding decoding algorithm. Thus, different data code readers (of different vendors) can potentially produce slightly different results in the print quality assessment"</p> <p>Overall Quality Minimum of all individual grades</p> <p>Contrast Range between minimum and maximum pixel intensity in the data code domain. A strong contrast results in a good grading</p> <p>Modulation Indicates how strong the amplitudes of the data code modules are. Big amplitudes make the assignment of the modules to black or white more certain, resulting in a high modulation grade. It is to note that the computation of the modulation grade is influenced by the specific level of error correction capacity, meaning that the modulation degrades less for codes with higher error correction capacity</p> <p>Fixed Pattern Damage Degradation or damage of the fixed pattern, or the respective quiet zones, is assessed with the Fixed Pattern Damage quality</p> <p>Decode Always takes the grade 4, meaning that the code could be decoded</p> <p>Axial Non-uniformity Due to a potentially oblique view of the camera onto the data code or a defective fabrication of the data code itself, the width to height ratio can be distorted. This deterioration results in a degraded Axial Nonuniformity</p> <p>Grid Non-uniformity If apart from an affine distortion the data code is subject to perspective or any other distortions too this degrades the Grid Nonuniformity quality</p>

Property

Quality ISO/
IEC 15415

Unused Error Correction

As data codes are redundant codes, errors in the modules or codewords can be corrected. The amount of error correcting capacities which is not already used by the present data code symbol is expressed in the Unused Error Correction quality. In a way, this grade reflects the reliability of the decoding process. Note, that even codes with an Unused Error Correction grading of 0, which could possibly mean a false decoding result, can be decoded in a reliable way, because the implemented decoding functionality is more sophisticated and robust compared to the reference decode algorithm proposed by the standard

The following results appear after quality testing in accordance with DPM-1-2006. The evaluation of code quality is specified as a number between 0 and 4, 0 being the worst and 4 the best evaluation.

Quality AIM DPM-1-2006	Overall Quality	Minimum of all individual grades
	Cell Contrast	Range between minimum and maximum pixel intensity in the data code domain. A strong contrast results in a good grading
	Cell Modulation	Indicates how strong the amplitudes of the data code modules are. Big amplitudes make the assignment of the modules to black or white more certain, resulting in a high modulation grade. It is to note that the computation of the modulation grade is influenced by the specific level of error correction capacity, meaning that the modulation degrades less for codes with higher error correction capacity
	Fixed Pattern Damage	Degradation or damage of the fixed pattern, or the respective quiet zones, is assessed with the Fixed Pattern Damage quality
	Decode	Always takes the grade 4, meaning that the code could be decoded
	Axial Nonuniformity	Due to a potentially oblique view of the camera onto the data code or a defective fabrication of the data code itself, the width to height ratio can be distorted. This deterioration results in a degraded Axial Nonuniformity
	Grid Nonuniformity	If apart from an affine distortion the data code is subject to perspective or any other distortions too this degrades the Grid Nonuniformity quality

Property

<p>Quality AIM DPM-1-2006</p>	<p>Unused Error Correction</p> <p>As data codes are redundant codes, errors in the modules or codewords can be corrected. The amount of error correcting capacities which is not already used by the present data code symbol is expressed in the Unused Error Correction quality. In a way, this grade reflects the reliability of the decoding process. Note, that even codes with an Unused Error Correction grading of 0, which could possibly mean a false decoding result, can be decoded in a reliable way, because the implemented decoding functionality is more sophisticated and robust compared to the reference decode algorithm proposed by the standard</p> <p>Mean Light</p> <p>Estimation for the quality of the processed image The value of Mean Light is not a grade specified with AIM DPM-1-2006 standard. It is an estimation for the quality of the processed image computed as the mean gray-scale value of the centers of the light data code modules. It is a value between 0.0 and 1.0, corresponding to 0% to 100% of the maximum gray-scale value.</p> <p>Note: More detailed information regarding the results of quality testing can be found in the corresponding standards.</p>
<p>Envelope</p>	<p>The read code surrounding polygon.</p>

11.12.3.2. Search Box

Objective

The image area within which codes are detected can specified. With the help of a smaller search box, transmission time is **reduced** and the refresh rate is **increased**.
Note: The area to be examined must be lie completely within the search box.

Image Area

By default, the search box encompasses the entire camera image. It appears in the image area as a dashed frame, where it can be adjusted.

Property

Search box settings are also displayed in the settings/results area.

<p>Width</p>	<p>Width of the readout box</p>
<p>Height</p>	<p>Height of the readout box</p>

The following settings/results are displayed for the search box under origin:

<p>X (px)</p>	<p>Coordinate of the sensor image coordinate system (see section 18.3)</p>
<p>Y (px)</p>	

11.12.4. General settings for all Code Types

Property The following settings/results appear.

Polarity	Describes the polarity of the symbol in the image, i.e., the parameter determines if the symbol appears light on a dark background or dark on a light background. Values: 'dark_on_light', 'light_on_dark', 'any'. Default: 'dark_on_light' (Enhanced: 'any')
Mirrored	Describes whether the symbol is or may be mirrored (which is equivalent to swapping rows and columns of the symbol). Values: 'no', 'yes', 'any' Default: 'any'
Contrast Min	Minimum contrast between the foreground and the background of the symbol (this measure corresponds with the minimum gradient between the symbol's foreground and the background). Values: [1...100] Default: 30 (Enhanced: 10)
Small Modules Robustness	Robustness of the decoding of data codes with very small module sizes. Setting the parameter 'Small Modules Robustness' to 'high' increases the likelihood of being able to decode data codes with very small module sizes. Additionally in that case the minimum module size should also be adapted accordingly, thus 'Module Size Min' and 'Module Width Min' (PDF417) should be set to the expected minimum module size and width, respectively. Setting 'Small Modules Robustness' to 'high' can significantly increase the internal memory usage. Thus, in the default case 'Small Modules Robustness' should be set to 'low'. Values: 'low', 'high' Default: 'low' (Enhanced: 'low', Maximum: 'high')
Strict Model	Controls the behavior while detecting symbols that could be read but that do not fit the model restrictions on the size of the symbols. They can be rejected (strict model, set to 'yes') or returned as a result independent of their size and the size specified in the model (lax model, set to 'no'). Values: 'yes' (strict), 'no' (not strict) Default: 'yes'

11.12.5. Data Matrix ECC 200

Property

Symbol Columns Min	Minimum number of module columns in the symbol. Value range: [10...144] – even Default: 10																				
Symbol Columns Max	Maximum number of module columns in the symbol. Value range: [10...144] – even Default: 144																				
Symbol Rows Min	Minimum number of module rows in the symbol. Value range: [8...144] – even Default: 8																				
Symbol Rows Max	Maximum number of module rows in the symbol. Value range: [8...144] – even Default: 144																				
Symbol Shape	<p>Possible restrictions on the module shape (rectangle and/or square). Attention: setting the symbol shape all previously made restrictions concerning the symbol size may change. For 'square' the minimum of 'Symbol Columns Min' and 'Symbol Rows Min' and the maximum of 'Symbol Columns Max' and 'Symbol Rows Max' will be used. Additional restrictions can be seen in the following table:</p> <table border="1" data-bbox="330 671 1020 863"> <thead> <tr> <th></th> <th>'any'</th> <th>'rectangle'</th> <th>'square'</th> </tr> </thead> <tbody> <tr> <td>'Symbol Columns Min'</td> <td>10</td> <td>18</td> <td>10</td> </tr> <tr> <td>'Symbol Columns Max'</td> <td>144</td> <td>48</td> <td>144</td> </tr> <tr> <td>'Symbol Rows Min'</td> <td>8</td> <td>8</td> <td>10</td> </tr> <tr> <td>'Symbol Rows Max'</td> <td>144</td> <td>16</td> <td>144</td> </tr> </tbody> </table> <p>Furthermore, if 'Symbol Columns Min' is larger than 'Symbol Rows Max', the setting for 'Symbol Shape' is ignored and its value set to 'rectangle'. If 'Finder Pattern Tolerance' is set to 'high' or 'any', the value of 'Symbol Shape' may speed up the symbol search significantly if it is set to 'rectangle' or 'square'. Values: 'rectangle', 'square', 'any' Default: 'any'</p>		'any'	'rectangle'	'square'	'Symbol Columns Min'	10	18	10	'Symbol Columns Max'	144	48	144	'Symbol Rows Min'	8	8	10	'Symbol Rows Max'	144	16	144
	'any'	'rectangle'	'square'																		
'Symbol Columns Min'	10	18	10																		
'Symbol Columns Max'	144	48	144																		
'Symbol Rows Min'	8	8	10																		
'Symbol Rows Max'	144	16	144																		
Module Size Min	Minimum size of the modules in the image in pixels. Values: [1...100] Default: 6 (Enhanced: 2, Maximum: 1)																				
Module Size Max	Maximum size of the modules in the image in pixels. Values: [2...100] Default: 20 (Enhanced: 100)																				
Module Gap Min	Minimum gap in direction of the symbol rows and columns. Values: 'no', 'small', 'big' Default: 'no'																				
Module Gap Max	Maximum gap in direction of the symbol rows and columns. Values: 'no', 'small', 'big' Default: 'small' (Enhanced: 'big')																				
Slant Max	Maximum deviation of the angle of the Lshaped finder pattern from the (ideal) right angle (the angle is specified in radians and corresponds to the distortion that occurs when the symbol is printed or during the image acquisition). Value range: [0.0...0.5235] Default: 0.1745 = 10° (Enhanced: 0.5235 = 30°)																				

Property	Finder Pattern Tolerance	Tolerance of the search with respect to a disturbed or missing finder pattern. The finder pattern includes the L-shaped side as well as the opposite alternating side. Dependent on this parameter, different algorithms are used during the symbol search. In one case ('low'), it is assumed that the finder pattern is present to a high degree and shows almost no disturbances. In the other case ('high'), the finder pattern may be heavily disturbed or missing completely without influencing the recognition and the reading of the symbol. Note, however, that in this mode the parameters for the symbol search should be restricted as narrow as possible. Otherwise the run-time may significantly increase. Also note that the two algorithms slightly differ from each other in terms of robustness. This may lead to different results depending on the value of 'Finder Pattern Tolerance' even if the finder pattern of the symbol is not disturbed. For example, if 'high' is chosen, only symbols with an equidistant module grid can be found (see below), and hence the robustness to perspective distortions is decreased. Finally, if 'Finder Pattern Tolerance' is set to 'any' both algorithms are applied. Values: 'low', 'high', 'any' Default: 'low' (Enhanced: 'low', Maximum: 'any')
	Module Grid	Describes whether the size of the modules may vary (in a specific range) or not. Dependent on this parameter different algorithms are used for calculating the module's center positions. If it is set to 'fixed', an equidistant grid is used. Allowing a variable module size ('variable'), the grid is aligned only to the alternating side of the finder pattern. With 'any' both approaches are tested one after the other. Please note that the value of 'Module Grid' is ignored if 'Finder Pattern Tolerance' is set to 'high'. In this case an equidistant grid is assumed. Values: 'fixed', 'variable', 'any' Default: 'fixed' (Enhanced: 'any')

11.12.6. QR Code

Property	Model Type	Type of the QR Code model. The old QR Code Model 1 and the newer Model 2 are supported. Values: 1, 2, 'any' Default: 'any'
	Version Min	Minimum symbol version. The symbol version is directly linked to the symbol size. Symbols of version 1 are 21x21 modules in size, version 2 = 25x25 modules, etc. up to version 40 = 177x177 modules. The maximum size of Model 1 symbols is 73x73 = version 14. Value range: [1...40] (Model 1: [1...14]) Default: 1
	Version Max	Maximum symbol version. Value range: [1...40] (Model 1: [1...14]) Default: 40
	Symbol Size Min	Minimum size of the symbol in modules. This parameter can be used as an alternative to 'Version Min'. Value range: [21...177] (Model 1: [21...73]) Default: 21
	Symbol Size Max	Maximum size of the symbol in modules. This parameter can be used as an alternative to 'Version Max': Value range: [21...177] (Model 1: [21...73]) Default: 177
	Module Size Min	Minimum size of the modules in the image in pixels. Values: [1...100] Default: 6 (Enhanced: 2, Maximum: 1)
	Module Size Max	Maximum size of the modules in the image in pixels. Values: [2...100] Default: 20 (Enhanced: 100)

Property	Module Gap Min	Minimum gap in direction of the symbol rows and columns. Values: 'no', 'small', 'big' Default: 'no'
	Module Gap Max	Maximum gap in direction of the symbol rows and columns. Values: 'no', 'small', 'big' Default: 'small' (Enhanced: 'big')
	Position Pattern Min	Number of position detection patterns that have to be visible for generating a new symbol candidate. Value range: [2, 3] Default: 3 (Enhanced: 2)

11.12.7. PDF417

Property	Symbol Columns Min	Minimum number of data columns in the symbol in codewords, i.e., excluding the codewords of the start/stop pattern and of the two row indicators. Value range: [1...30] Default: 1
	Symbol Columns Max	Maximum number of data columns in the symbol in codewords, i.e., excluding the two codewords of the start/stop pattern and of the two indicators. Value range: [1...30] Default: 20 (Enhanced: 30)
	Symbol Rows Min	Minimum number of module rows in the symbol. Value range: [3...90] Default: 5 (Enhanced: 3)
	Symbol Rows Max	Maximum number of module rows in the symbol. Value range: [3...90] Default: 45 (Enhanced: 90)
	Module Width Min	Minimum module width in the image in pixels. Values: [1...100] Default: 3 (Enhanced: 2, Maximum: 1)
	Module Width Max	Maximum module width in the image in pixels. Values: [2...100] Default: 15 (Enhanced: 100)
	Module Aspect Min	Minimum module aspect ratio (module height to module width). Values: [0.5...20.0] Default: 1.0
	Module Aspect Max	Maximum module aspect ratio (module height to module width). Values: [0.5...20.0] Default: 4.0 (Enhanced: 10.0)

11.13. Module Image Comparison

11.13.1. Overview

Objective Objects can be compared with the stored Reference Image and any deviations can be reliably detected with the help of the Module Image Comparison.

Prerequisites

1. Sensor is correctly connected (see section 5.5)
2. Connection has been established from the sensor to the software (see section 10.1.1)
3. Region of interest is specified (see section 11.5)

Procedure First of all, one or more images (see Teach Image Count) of good parts will be used to calculate the Reference Image.

Then the Input Image will be compared pixel by pixel with the Reference Image. If the deviation of a pixel is bigger than the value of the pixel in the Threshold Image, the pixel will be marked as an error (white) in the Output Image. If the deviation is smaller than the value of pixel in the Threshold Image, the pixel of the Input Image is marked as an accepted (black) value in the Output Image (only visible in Advanced Mode).

The errors are also visible if you click in the Module Image Comparison itself. To make them more visible, they are marked red.

11.13.2. Settings

Image Area Deviations from the reference object are displayed as red pixels in the image area.

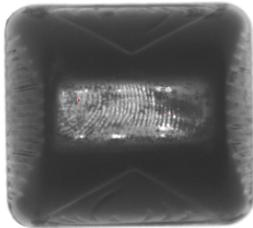

Reference Object

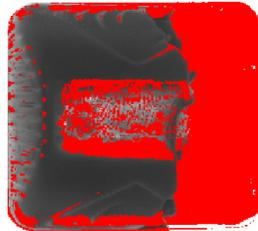

Displayed Deviation from the Reference Object

Property

The following settings/results are displayed:

Process Time [ms]	Sensor processing time for the module
Module State	Error codes to give support in error diagnosis (see section 18.5)
Pixel Count	Number of pixels by which the respective image deviates from the original image. The larger the number, the greater the deviation from the original image.
Input Image	Selection of the Input Image.
Input Region	Selection of the region for image comparison.
Threshold Background	<p>"Threshold value for acceptable brightness differences between a pixel of the Input Image and a pixel of the Reference Image on the whole image except the detected edges (see Threshold Border). The higher the value, the higher the tolerance.</p> <p>Range 0-255: Value 0: Highest sensitivity, even the slightest brightness differences are marked as errors.</p>
Threshold Border	Threshold value for acceptable brightness differences along the detected edges (see Edge Sensitivity (%) and Threshold Image). Setting of values: see Threshold Background
Edge Broadening (px)	Pixel width of the edges – the detected edges will be broadened by this value
Teach Image Count	The number of images whose characteristics are combined into a reference image.
Teach	Activation of the teach-in process. After a successful teach-in process, a display appears indicating how many of the image recordings have been combined into a reference image.
Edge Sensitivity (%)	A setting which determines which percentage of the detected edges will be evaluated as edges of the Reference Image. The default value is 20%.

11.13.3. Configuration

The image comparison module includes the following configuration:

- Output Image.
- Reference Image.
- Threshold Image.

11.13.3.1. Output Image

Objective

The differences between the reference image and the current image are displayed as a binary image after clicking the Output Image. Errors are marked white, accepted values are marked black.

Property

The following settings/results are displayed:

Image Type	Display of the image type
X (px)	Coordinate of the sensor image coordinate system (see section 18.3)
Y (px)	
Width (px)	Image width
Height (px)	Image height

The following settings/results are displayed under Binary:

Size	Number of pixels in the image
Bits per Pixel	Display of the number of bits required to transmit one pixel
Channel Type	The binary channel type is displayed.

11.13.3.2. Reference Image

Objective The taught in reference image is displayed after clicking the Reference Image.

Property The following settings/results are displayed:

Image Type	Display of the image type
X (px)	Coordinate of the sensor image coordinate system (see section 18.3)
Y (px)	
Width (px)	Image width
Height (px)	Image height

The following settings/results are displayed under 8-bit:

Size	Number of pixels in the image
Bits per Pixel	Display of the number of bits required to transmit one pixel
Channel Type	The generic 8-bit channel type is displayed.

The following settings/results are displayed under Transformed Mask:

Size	Number of pixels in the image
Bits per Pixel	Display of the number of bits required to transmit one pixel
Channel Type	The mask channel type is displayed.

11.13.3.3. Threshold Image

Objective The binary threshold image is displayed after clicking the Threshold Image.

Property The following settings/results are displayed:

Image Type	Display of the image type
X (px)	Coordinate of the sensor image coordinate system (see section 18.3)
Y (px)	
Width (px)	Image width
Height (px)	Image height

The following settings/results are displayed under 8-bit:

Size	Number of pixels in the image
Bits per Pixel	Display of the number of bits required to transmit one pixel
Channel Type	The generic 8-bit channel type is displayed.

11.14. Module OCR (optical character reader)

11.14.1. Overview

Goal Read letters, numbers and symbols.

Prerequisites

1. The sensor is correctly connected (see section 5.5).
2. Connection has been established from the sensor to the software (see section 10.1.1).
3. The camera is configured / images are selected (see section 11.2).
4. If applicable, tracking is configured (see sections 11.3.2 and 11.4).

Procedure First specify the region within which the characters are located. Then select the segmentation settings. The next step involves associating the detected character with a letter or a number.

11.14.2. Parameter Settings

Characteristic The following settings/results are displayed:

Processing time [ms]	Sensor processing time for the module
Module status	Error codes for troubleshooting support (see section 18.6).
Segments found	Number of detected characters
Reading results	Read-out of all reading results for all detected lines. The lines are separated from each other by a line feed (LF).
Input image	Selection of the channel for image input
Coordinate system	Selection can be made regarding how the OCR module should be tracked.
Reading timeout [ms]	The time during which an attempt is made to read the characters. If reading is not successful within this period of time, the process is aborted and the reading results are rendered invalid.
Maximum number of segments	The maximum number of segments is specified.

11.14.3. Configuration

The OCR module includes the following configuration options:

- Results list
- Segment list
- Search region
- Find lines
- Binarization
- Segmentation
- Classification
- Replacement

11.14.3.1. Results List

Characteristic The following settings/results are displayed:

Reading results #0...n	The characters read from the detected line are displayed.
------------------------	---

Reading results are read out for each detected line.

11.14.3.2. Segment List

Goal Detected characters are listed in the sub-module in order to provide information concerning the detected segment. This information can be used to further optimize the overall settings.

Characteristic The following settings/results are displayed for any given selected segment:

Assigned character	If an appropriate character has been found in the character set, it's displayed. Otherwise, the default replacement character appears, namely a question mark (?).
Lower threshold value	Lowest binarization value that has been used to binarize the character.
Upper threshold	Highest binarization value that has been used to binarize the character.
Height	Height of the character
Width	Width of the character
Scoring	Specifies the value which indicates how closely the scanned character coincides with the utilized character from the character set. If no comparable character is found in the character set, the assessment value is 0. If the scanned character coincides precisely to the utilized character from the character set, the value is 1000.

11.14.3.3. Search Region

Goal The area of the image within which characters will be searched for can be specified. Using a small search region **reduces** evaluation time and **increases** the refresh rate.

Characteristic The following settings/results are displayed for any given selected segment
The following settings/results for the search region are displayed under reference point:

X (px)	Coordinate of the image sensor's coordinate system (see section 18.3).
Y (px)	

The search region settings are also displayed in the characteristics:

Width (px)	Search box width
Height (px)	Search box height
Phi (degrees)	Search box rotation angle

11.14.3.4. Find Lines

Goal The module can read out several lines from a search region. The presets for the lines to be expected are entered under "find lines".

Characteristic The following settings/results are available:

Line detection	This function is initially deactivated. The search algorithm is activated by switching the mode to standard.
Angle [degrees]	If the angle range is set to 0, the module automatically calculates the angle of the rows with reference to the search region. The resulting value is displayed.
Maximum number of lines	The number of lines to be expected is specified.
Angle range [degrees]	The angle between the search region and the expected lines is specified. If this value is set to 0, the module calculates the angle automatically.
Min. line height (px)	Minimum height of the expected lines
Max. line height (px)	Maximum height of the expected lines
Min. line spacing (px)	The search algorithm of each line is expanded by one-third of the line spacing value in positive or negative direction.

11.14.3.5. Binarization

Goal The characters are separated from the background with the help of the binarization threshold. It must be determined which type of character is involved and which operating mode needs to be used. Selection can be made between several binarization modes.

Characteristic The following settings/results are available:

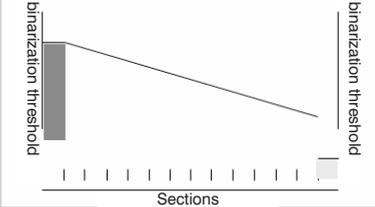
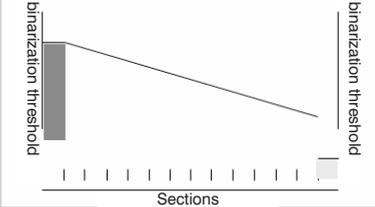
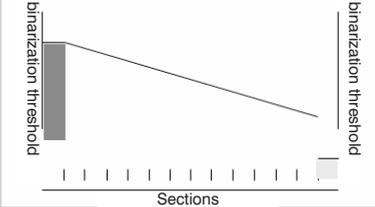
Contrast	The mode of application is specified, i.e. dark characters on a light background or light characters on a dark background.								
Threshold value mode	<p>The following options are available:</p> <table border="1" data-bbox="421 456 994 1227"> <tr> <td data-bbox="421 456 596 549">Manual</td> <td data-bbox="596 456 994 549">The binarization threshold is set manually by specifying the lower and upper threshold values.</td> </tr> <tr> <td data-bbox="421 549 596 612">Calculation</td> <td data-bbox="596 549 994 612">The binarization threshold is calculated automatically by the OCR algorithm.</td> </tr> <tr> <td data-bbox="421 612 596 927">Linear</td> <td data-bbox="596 612 994 927"> <p>This mode is used when a linear brightness profile can be detected in the image.</p>  </td> </tr> <tr> <td data-bbox="421 927 596 1227">Non-linear</td> <td data-bbox="596 927 994 1227"> <p>This mode is used when the image is not homogeneously illuminated. In the case of non-linear calculation of the binarization threshold, the image is broken down into predetermined sections, and the best possible binarization threshold is calculated for each.</p>  </td> </tr> </table>	Manual	The binarization threshold is set manually by specifying the lower and upper threshold values.	Calculation	The binarization threshold is calculated automatically by the OCR algorithm.	Linear	<p>This mode is used when a linear brightness profile can be detected in the image.</p> 	Non-linear	<p>This mode is used when the image is not homogeneously illuminated. In the case of non-linear calculation of the binarization threshold, the image is broken down into predetermined sections, and the best possible binarization threshold is calculated for each.</p> 
Manual	The binarization threshold is set manually by specifying the lower and upper threshold values.								
Calculation	The binarization threshold is calculated automatically by the OCR algorithm.								
Linear	<p>This mode is used when a linear brightness profile can be detected in the image.</p> 								
Non-linear	<p>This mode is used when the image is not homogeneously illuminated. In the case of non-linear calculation of the binarization threshold, the image is broken down into predetermined sections, and the best possible binarization threshold is calculated for each.</p> 								
Linear/non-linear threshold value splitting	This value specifies into how many parts the search region will be split up in order to calculate the individual threshold values.								

11.14.3.6. Segmentation

Goal The characters are separated from each other with the help of segmentation. The module makes use of various automatic methods. If these automatic methods do not lead to the desired results, various segmentation settings can be entered manually.

Characteristic The following settings/results are available:

Min. character height [px]	The minimum height of the character to be detected is specified.
Max. character height [px]	The maximum height of the character to be detected is specified.
Min. character width [px]	The minimum width of the character to be detected is specified.
Max. character width [px]	The maximum width of the character to be detected is specified.
Min. cluster size [px]	The minimum number of pixels which must be contained by a segment in order to be detected as a character
Max. cluster size [px]	The maximum number of pixels which may be contained by a segment in order to be detected as a character



Smallest outlier	If the requirements concerning height, width and cluster size are fallen short of, the detected segment is disregarded.						
Largest outlier	If the requirements concerning height, width and cluster size are exceeded, the detected segment is disregarded.						
Vertical pixel pitch [px]	The vertical pixel pitch for fonts which are made up of individual pixels is specified.						
Horizontal pixel pitch [px]	The horizontal pixel pitch for fonts which are made up of individual pixels is specified.						
Distribution	<p>The following options are available:</p> <table border="1"> <tr> <td>Standard</td> <td>Fixed distribution of the characters is assumed. Character spacing and angle do not vary.</td> </tr> <tr> <td>Variable</td> <td>Distribution of the characters with regard to spacing, angle and size may vary.</td> </tr> <tr> <td>Dynamic</td> <td>Distribution of the characters with regard to spacing, angle and size may vary greatly.</td> </tr> </table>	Standard	Fixed distribution of the characters is assumed. Character spacing and angle do not vary.	Variable	Distribution of the characters with regard to spacing, angle and size may vary.	Dynamic	Distribution of the characters with regard to spacing, angle and size may vary greatly.
Standard	Fixed distribution of the characters is assumed. Character spacing and angle do not vary.						
Variable	Distribution of the characters with regard to spacing, angle and size may vary.						
Dynamic	Distribution of the characters with regard to spacing, angle and size may vary greatly.						

Characteristic	Character spacing [px]	Character spacing specifies the expected number of pixels between the segments.
	Replacement character	If a detected character cannot be found in the taught-in character set, the replacement character is displayed.
	Inclination mode	The minimum width of the character to be detected is specified.
	Inclination angle [degrees]	The inclination angle of the characters can be specified. The value can lie within a range of -45° to $+45^{\circ}$.



11.14.3.7. Classification

Goal Classification specifies as of which degree of conformity a character is selected from the character set. The higher the degree of conformity, the more precisely the characters must conform.

Characteristic The following settings/results are available:

Acceptance value	The current character is compared with the character from the character set and coincidence is evaluated. The higher the value the greater the coincidence. The acceptance value specifies the minimum degree of coincidence which must be achieved for the character to be read out as recognized.
------------------	---

11.14.3.8. Insert

Goal This function makes it possible to filter the detected characters on the basis of certain criteria.

Characteristic The following settings/results are available:

Pattern	This is used to specify at which place which character can be used in the results read-out. Which characters are associated with which abbreviation is defined in the set sub-step.
---------	---

One letter from the defined set must be entered per place in the output value. If the field is empty, the reading results from the OCR module are read out without restriction.

Set

The following patterns have already been specified:

N	0123456789
A	ABCDEFGHIJKLMNOPQRSTUVWXYZ (uppercase letters)
a	abcdefghijklmnopqrstuvwxyz (lowercase letters)
H	0123456789ABCDEF (hexadecimal, uppercase)
h	0123456789abcdef (hexadecimal, lowercase)
O	1234567 (octal numbers only)
N	A set of characters can be defined by the user. An explicit letter must be assigned to the subset as a characteristic.

11.14.3.9. Teaching Characters In

Goal

If characters from the fonts OCR-A or OCR-B need to be read, the included OCR-A and OCR-B fonts can be used. If the characters are from any other font, they first have to be taught in.

Function field

New characters can be taught in to the toolbar module. Taught-in characters can be managed with the help of a character editor.

	Teach line in	All of the characters within the search region are taught in.
	Character editor	The character editor is a separate window which makes it possible to manage taught-in characters, as well as to save and load fonts.

The character editor manages the currently used character set. Additional information is available for each character, such as height and width. The number of hits indicates how frequently the character has been used since the program was last started. If the same character has been taught in more than once, information concerning the number of hits is helpful for finding out whether or not a character is actually necessary for the current application. After clicking the small image, a larger image of the taught-in character is displayed.

Each character can be individually removed from the character set by clicking the X in the respective column.

Note: The smaller the character set, the higher the evaluation speed.

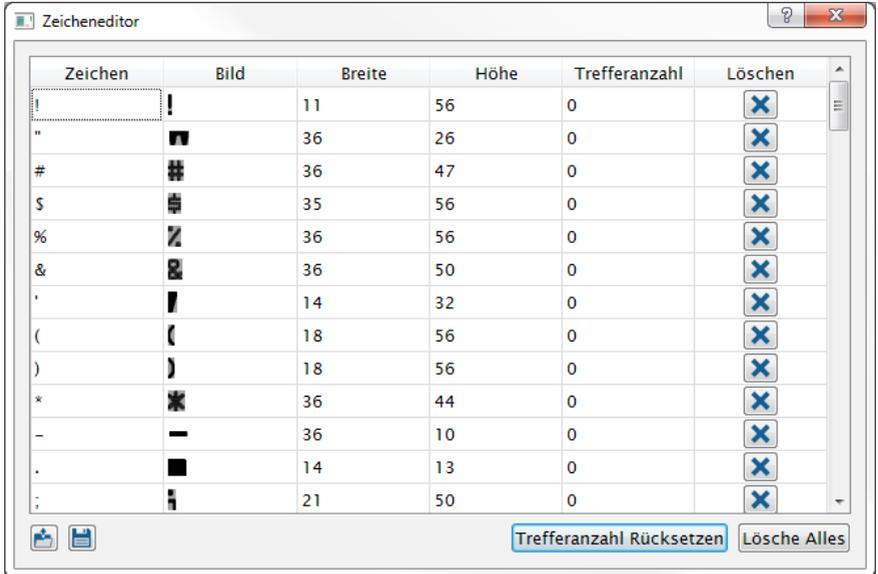

The current character is compared with the character from the character set and coincidence is evaluated. The higher the value the greater the coincidence. The acceptance value specifies the minimum degree of coincidence which must be achieved for the character to be read out as recognized.

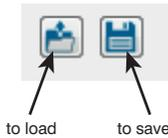

11.15. OCR-Tip

This chapter is intended to explain the basic requirements for setting up wenglor's OCR Reader. By considering several important attributes, it can be determined whether or not this product is suitable for the respective application.

In actual practice, a great number of ambient conditions influence whether or not reading will be successful. This document only deals with the issues of geometry and contrast.

The most important attributes are:

- Character geometry
- Quiet zone
- Background / contrast

11.15.1. Basic Character Geometry

- The OCR Reader functions ideally as of a **character height of 25 pixels**. In this case, as a rule, the gap between the characters are large enough for the characters to be separated.
- The OCR Reader functions ideally when the gap between the characters is **half as large as the character width**.
- If “non-linear calculation of the binarization threshold” is used, the gap between the characters should not be any larger than one character. Otherwise the gap itself might be recognized as a character under certain circumstances. In this case, two objects should be used.
- Processing time has a **quadratic relationship to character size**. If a character string with a character height of 25 pixels requires 20 ms for the reading algorithm, time is increased to 80 ms for a character height of 50 pixels.

11.15.1.1. Examples

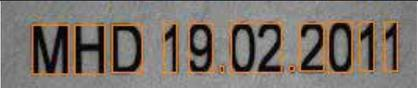
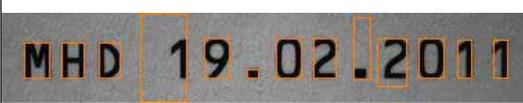
Font: Arial Standard Height: 30 pixels → “02” cannot be segmented.	
Font: OCR B Height: 30 pixels → All characters can be readily segmented.	
Font: OCR B Height: 30 pixels Binarization: “non-linear calculation” → Excessively large spaces are seen as separate segments.	

11.15.2. Size of the ROI

If the region of interest is too large, the algorithm for determining the binarization threshold does not function reliably.

The following rule of thumb applies:

Left/right edge spacing: 1 x character width
Top/bottom edge spacing: 0.5 x character width

This “**quiet zone**” should not be interfered with by other characters or objects.

Furthermore, processing time also increases when the ROI is too large.

If the position of the character string to be read is not consistent in actual practice, it’s usually better to use localization instead of a very large ROI. Processing time for localization plus reading is usually less than required for a large ROI.

11.15.2.1. Examples

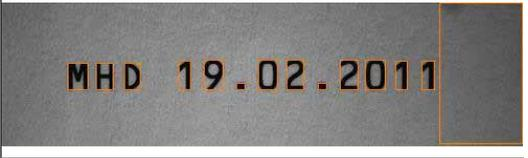
Ideal edge spacing Reading time: 25 ms	
Edge spacing too large: The segmentation function detects additional object because an incorrect binarization threshold is calculated due to the large surface area of the image. Reading time: 120 ms	

11.15.3. Background

A homogenous background is always ideal for character segmentation. Structures included in the background which have an intensity similar to that of the characters make reading impossible.

Under certain circumstances, colored structures can be eliminated by using the right illumination color. If fine structures are present in the background, it may be helpful to make use of a Gaussian filter or set the optics slightly out of focus depending upon character size.

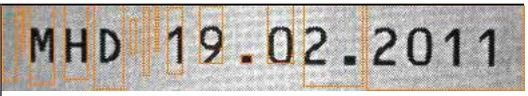
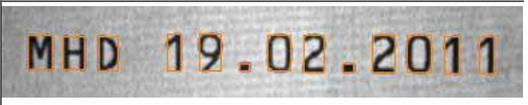
Character string with structure in background → segmentation is not possible.	
Character string with structure in background → segmentation functions correctly.	

11.15.4. Contrast

The “binarization” stage must find a suitable binarization threshold for separating the characters from the background on the basis of image contrast. The OCR module is equipped with various binarization functions to this end.

If contrast (difference in intensity between characters and background) is constant over the entire ROI, 20 intensity values are enough for display.

If contrast varies within the ROI (e.g. due to inhomogeneous illumination), there should be a plain difference between the characters and the background. The sensor functions ideally if the image is set up with black characters (intensity = 0) and a gray background. In this case, brightness differences within the characters are outside of the image chip’s dynamic range, and the characters are entirely black.

On the other hand, an attempt can be made to fully over-illuminate the background (white, i.e. intensity = maximum). In this way, structures in the background can no longer be detected and only the characters are gray.

11.15.4.1. Examples

Dark illumination, structures in the characters are not visible.	
Background over-illuminated, small structures in the background are not visible.	

11.16. Module Pattern Match

11.16.1. Overview

Objective	Recognize objects in an image
Prerequisite	<ol style="list-style-type: none"> 1) The sensor is correctly connected (see section 5.5). 2) Connection has been established from the sensor to the software (see section 10.1.1). 3) The camera is configured / images are selected (see section 11.21).
Procedure	First of all, specify the object or a distinctive element of the object which needs to be recognized. Then specify tolerances for rotational orientation. Teach in and you're done.

11.16.2. Setting Parameters

Characteristic	The following settings/results are displayed:	
	Processing Time [ms]	Sensor processing time for the module
	Module State	Error code for troubleshooting support (see section 18.6)
	Reading True Count	The number of detected objects is displayed.
	Input Image	Selection of the channel for image input
	Reading Timeout [ms]	The time during which the sensor attempts to detect the object. If nothing has been successfully detected after this duration has expired, the search is aborted and the result is set to invalid. Time can be set within a range of 0 to 20 seconds in steps of 1 ms. Aborting the read attempt takes about 20 ms. The module's minimum processing time is thus also 20 ms.
	Reading Max Count	The maximum number of objects to be detected can be selected. Up to 20 objects can be detected simultaneously.

Characteristic

Shape Models	Number of different models which should be detected. Up to 10 different models can be taught in.
Pyramid Levels	With a value of 0, the algorithm automatically optimizes the number of model points. A value of 1 specifies that model points will be looked for in the original image, and thus this setting is the slowest. If the value is increased to 2, the resolution of the original image is reduced by means of subsampling. Possible model points are thus also reduced and the process is accelerated. It must be noted that although processing time is reduced as the pyramid steps value is increased, accuracy is also reduced. We recommend leaving the setting at a value of 0, i.e. automatic.
Angle Start [deg]	This parameter specifies in which negative direction the model can be turned from the taught-in position. It describes the start angle from which the angle of rotation is determined on the basis of angle range. For example, if a start angle of -15° and an angle range of 30° are selected, the model can move within a range of -15° to $+15^\circ$.
Angle Extent [deg]	Angle extent specifies the possible range of angles of rotation for the model.
Angle Step [deg]	The angle step parameter specifies the individual increments within the selected angle range. The angle step parameter should be set on the basis of the object's size. Smaller models have only a number of different discrete rotations within the image. For this reason, a larger angle step should be selected for smaller objects.
Scale Min	This parameter specifies the lower limit of the possible scaling range which will be searched. A value of 1 corresponds to the model's original size.
Scale Max	This parameter specifies the upper limit of the possible scaling range which will be searched. A value of 1 corresponds to the model's original size.
Scale Step	Scale Step specifies the increment within the scaling range. As is also the case with the angle step parameter, scaling step should be set on the basis of the object's size.

Characteristic

<p>Optimization</p>	<p>In the case of especially large models, it may be advisable to select the number of model points by setting the optimization parameter to a value other than “-”. In the case of smaller models, reducing the number of points does not result in any acceleration.</p>	
	<p>Auto</p>	<p>The number of points is reduced automatically by the algorithm.</p>
	<p>-</p>	<p>No optimization is conducted. All object points are saved.</p>
	<p>Min Point Reduction</p>	<p>There are three different levels for reducing the number of points of a taught-in model. Reducing the number of points can be very helpful for large objects.</p>
	<p>Med Point Reduction</p>	
	<p>Max Point Reduction</p>	
	<p>Regeneration</p>	<p>If this parameter is selected, a new model is generated each time an image is recorded. It must be noted that regeneration in the case of large rotation or scaling values increases memory occupation. Regeneration also takes a great deal of time.</p>
	<p>No Regeneration</p>	<p>Regeneration of models is deactivated.</p>
<p>Metric</p>	<p>The metrics setting specifies the conditions under which the sample will still be recognized within the image.</p>	
	<p>Polarity – Active</p>	<p>The object in the image must demonstrate the same contrast characteristics as the model. For example, if the model is a bright object against a dark background, the object is only detected within the image if it's brighter than the background.</p>
	<p>Global Polarity – Ignore</p>	<p>The model is also detected when the contrast characteristics are exactly the opposite of those of the taught-in object.</p>
	<p>Local Polarity – Ignore</p>	<p>If this value is selected, contrast polarity may only change amongst various parts of the model, but the polarity of model points within the same part of the model may not change. The term “Local Polarity – Ignore” must be correctly understood. It means that changes in polarity between neighboring parts of the model don't influence the score and are thus ignored.</p>

Characteristic

Contrast	The contrast parameter specifies which gray-scale contrast the model's points must demonstrate. Contrast is a measure of local gray-scale differences between the object and the background, as well as between the parts of the object.	
	Auto	Contrast, upper and lower threshold values, and hysteresis are calculated automatically.
	Auto-Contrast	Only the contrast values are determined automatically.
	Auto-Contrast Hysteresis	The hysteresis threshold values are determined automatically.
	Auto Minimum Magnitude	The minimum contrast magnitude is only used for creating the model – the other influencing variables are not used.
	Numeric Value	This value specifies the minimum contrast value of an edge transition which must be achieved. The edge is only used for model generation if this value is reached.
Min Contrast	The minimum gray-scale contrast which the model will have to have within the image later on during detection is specified here. In other words, this parameter represents a demarcation of the sample from noise within the image. For this reason, a good value corresponds to the range of gray-scale change which is caused by noise within the image. For example, if gray-scale values fluctuate within a range of 10 due to noise, the value should be set to 10. The value must be less than the contrast parameter value.	
Min Score	Specify the quality of coincidence – the higher the value is set the more quickly evaluation is completed, but quality is reduced.	
Max Overlap	This parameter specifies how much of a taught-in model may be covered up, and nevertheless still detected as present.	

Characteristic

Sub Pixel	The sub pixel parameter defines whether the position and the orientation of the detected model will be read out with accuracy down to the pixel or the sub pixel.	
	---	The object's coordination and angle of rotation are read out with an accuracy of down to 1 pixel.
	Interpolation	When interpolation is activated, the algorithm examines the position of the object on the basis of neighboring pixels, angles and scaling around the best coincidence match. The results are accurate down to roughly one twentieth of a pixel. Interpolation is very fast and can be activated for most applications.
	Smallest Squares	The smallest squares parameter works against the interpolation parameter. This function requires a great deal of computing time.
	Smallest Squares – High	
	Smallest Squares – Very High	
	Max. Deformation 1	Sometimes no objects are found, or only objects with a minimal coincidence value, because they're highly deformed relative to the taught-in model. The max. deformation parameter specifies by how many pixels the detected object can differ from the taught-in object. Selection can be made between the Max. Deformation 1 and the Max. Deformation 2 parameters.
Max. Deformation 2		
Greediness	"Greediness" of the search heuristics (0: reliable but slow, 1: fast but matches may be overlooked).	

11.16.3. Configuration

The pattern matching module includes the following configuration options:

- Results list
- Search box
- Teach Box
- Shape models

11.16.3.1. Results List Sub-Module

Characteristic The following settings/results are displayed:

Reading #1	The name of the detected object is displayed.
Quality	The displayed number describes the quality of coincidence between the detected object and the taught-in models. The number can lie between 0 (not recognized) and 1 (full coincidence to the taught-in model).
Coordinate System	Details concerning the initial coordinate system are displayed. The coordinate system is comprised of the following parameters: Phi (degrees): coordinate system rotation in degrees X (px): distance of the coordinate system from the left-hand edge of the image chip X (px): distance of the coordinate system from the top edge of the image chip

11.16.3.2. Search Box Sub-Module

Objective The image area within which objects are detected can be specified. Using a small search box reduces processing time and increases the image refresh rate.

Image Area As a default feature, the search box encompasses the entire camera image. It appears in the image area as a dashed frame, where it can be adjusted.

Characteristics Search box settings are also displayed in the settings/results area.

Width (px)	Search box width
Height (px)	Search box height

The following settings are displayed under origin.

X (px)	Coordinates of the image sensor's coordinate system (see section 18.3)
Y (px)	

11.16.3.3. Teach Box

Objective The region which encompasses the object or the distinctive element is displayed and defined here.

Characteristics Teach region settings are also displayed in the settings/results area.

Width (px)	Teach region width
Height (px)	Teach region height

The following settings are displayed under reference point.

X (px)	Coordinates of the image sensor's coordinate system (see section 18.3)
Y (px)	

11.16.3.4. Shape Model

Objective Several objects can be taught-in. Each object is saved to the sensor as a separate shape model.

Characteristics Each shape model has a “teach-in” button. The current object is taught-in as a shape model when this button is clicked. After a model has been taught in successfully, its drawn into the camera image. It's possible to subsequently edit the taught-in shape model in order to eliminate any interference. An additional window can be opened to this end via the Shape model Outline parameter. The window appears after clicking the icon . The following window appears:

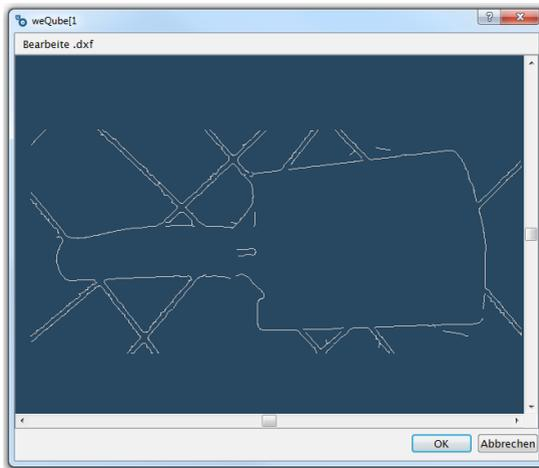

After clicking “Edit.dxf”, the mouse pointer turns into a red dot. This dot can be used to delete individual lines from the detected model. After correction of the model has been completed, the new contour is transmitted to the sensor by clicking OK. The “Undo” function negates the last change. The “Redo” function is the opposite of the “Undo” function and thus deletes the restored areas.

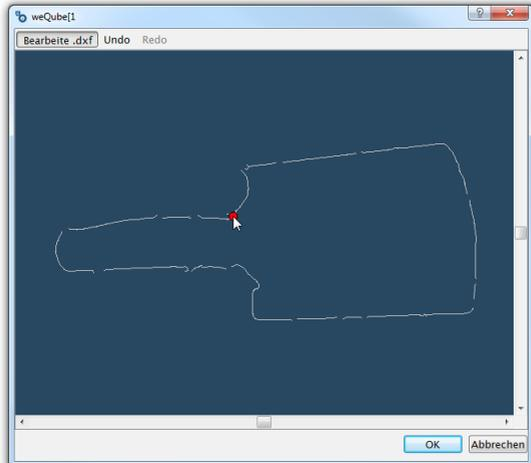

11.16.4. Tips

Make sure you have a sharp image with high contrast.

- Move the search region into the middle of the object. Enlarge the search region such that the object or feature you want to detect is enclosed.
- Teach the object in. It may take several seconds until the weQube teach-in process has been completed. Detected contours are displayed in the image. If additional, unnecessary contours are displayed which are not necessarily required for object detection, they should be removed with the help of the contour model editor. A larger number of contours to be searched for extends evaluation time, but it also improves the quality of the results. The ideal relationship between a minimal number of contours and best possible quality varies from application to application.
- Is it possible for the object to turn in the application? If so, the starting angle and the angle range should be set. For example, if it's possible for an object to turn 30 %, set the starting angle to -15° and the angle range to 30. With these settings, the object can rotate within a range of -15° to 15° from the previously taught-in position, and it's still recognized. It must be kept in mind that finding rotated objects requires computing time at the weQube. For this reason, the rotation angle should only be as large as necessary in order to prevent the need for unnecessary computing time.

The following parameters influence evaluation speed:

- Increase the minimum coincidence value step-by-step until the object is no longer detected. Then return to the last value that worked.
- Increase the aggressiveness parameter until pattern matching fails, and then reduce the coincidence value. If this doesn't deliver the desired results, return to the last values with which the object was found.
- Reduce the permissible rotation angle to a minimum.
- Reduce the search region to the size which is actually required for the application.
- Be sure to use contour models which demonstrate prominent structures that differ from the rest of the image. When recording the image, make sure that the prominent structures can be easily detected in the image. It's better to use large, prominent structures than small, faint structures. This can have a significant effect on speed.

11.17. Module Match Code

11.17.1. Overview

Objective	Determine whether or not the scanned code corresponds with the taught in match code.
Prerequisites	<ol style="list-style-type: none">1. Sensor is correctly connected (see section 5.5)2. Connection has been established from the sensor to the software (see section 10.1.1)3. The camera is configured / images are selected (see section 11.3)
Procedure	With the appropriate settings, a match code can be entered via this module.

11.17.2. Settings

Property

The following settings/results appear:

Process Time [ms]	Sensor processing time for the process steps
Module State	Error codes to give support in error diagnosis (see section 18.5)
Input String	The match code can either be entered statically as text or as a combination of text and characters, or dynamic reference can be made to a software parameter via a link.
Any Match	If any character string is identical to the input string, the parameter is set to 1 (check box activated).
No Match	If no character string is identical to the input string, the parameter is set to 1 (check box activated).
Number Elements	Number of possible texts for comparison

11.17.2.1. Number Elements

Property

The following settings/results appear:

Match	Display indicating whether or not the match code comparison was successful. Box activated: evaluation successful	
Mismatch	Display indicating whether or not the match code comparison was successful. Box activated: evaluation unsuccessful	
Match Code	The text or combination of characters to which comparison will take place is selected. The following wildcards are also available for the characters:	
	Place Holder	For Character
	*	Any number of characters
	?	Exactly one character
	[abc]	a, b or c may appear at this position.
[^ A]	Any character other than A at this position	
Match Teach	The current text or combination of characters is saved as a match code.	

11.18. Module Logic

11.18.1. Overview

Objective	Logically linking several values to each other.
Prerequisites	<ol style="list-style-type: none">1. Sensor is correctly connected (see section 5.5)2. Connection has been established from the sensor to the software (see section 10.1.1)3. The camera is configured / images are selected (see section 11.2)
Procedure	First of all, the values which will be linked to each other have to be identified. Fixed values, as well as results, can be used. The logic calculation is conducted step by step. Initially, the first two values are logically linked to each other and the result is then linked to the next value, and so forth. The logic is calculated in a cascaded manner.

11.18.2. Settings

Property The following settings/results appear.

Process Time [ms]	Sensor processing time for the module
Module State	Error codes to give support in error diagnosis (see section "18.5. weQube Software Module States" on page 201)
Output	The results are displayed.
Math Function	The type of mathematical function is specified: <ul style="list-style-type: none">• AND• OR• XORs• NAND• NOR
Input A	Fixed value or variable event from the application
Input B	Fixed value or variable event from the application

11.19. Module Math

11.19.1. Overview

Objective	Perform a mathematical operation with two numbers.
Prerequisites	<ol style="list-style-type: none"> 1. Sensor is correctly connected (see section “5.5. Initial Start-Up” on page 20) 2. Connection has been established from the sensor to the software (see section “10.1.1. Connecting the Sensor (Connect to Device)” on page 41) 3. The camera is configured / images are selected (see section “11.2. Camera Device Module” on page 69)
Procedure	First of all, the mathematical operands are specified which will be used to perform a mathematical operation with two numeric values. Fixed values, as well as results, can be used.

11.19.2. Settings

Property The following settings/results are displayed:

Process Time [ms]	Sensor processing time for the module
Module State	Error codes to give support in error diagnosis (see section “18.5. weQube Software Module States” on page 201)
Output	The calculated results are displayed.
Math Function	The type of mathematical function is specified: <ul style="list-style-type: none"> • + • - • * • /
Input #n	Fixed value or variable event from the application
Max. Inputs	Specifies the maximum number of inputs. Fixed values or variable results from the application can be assigned to these inputs.

11.20. Module Numeric Comparison

11.20.1. Overview

Objective	Compare two numbers with each other.
Prerequisites	<ol style="list-style-type: none"> 1. Sensor is correctly connected (see section “5.5. Initial Start-Up” on page 20) 2. Connection has been established from the sensor to the software (see section “10.1.1. Connecting the Sensor (Connect to Device)” on page 41) 3. The camera is configured / images are selected (see section “11.2. Camera Device Module” on page 69)
Procedure	First of all, the mathematical operands are specified which will be used to compare the two numeric values. Fixed values, as well as results, can be used.

11.20.2. Settings

Property The following settings/results appear.

Process Time [ms]	Sensor processing time for the module
Module State	Error codes to give support in error diagnosis (see section “18.5. weQube Software Module States” on page 201)
Output	The calculated results are displayed.
Math Function	The type of mathematical function is specified: <ul style="list-style-type: none"> • $A > B$ • $A < B$ • $A \geq B$ • $A \leq B$ • $A \neq B$
Input #n	Fixed value or variable event from the application
Max. Inputs	Specifies the maximum number of inputs. Fixed values or variable results from the application can be assigned to these inputs.

11.21. Device IO Unit

11.21.1. Overview

Objective	The inputs and outputs can be configured in order to specify which action will take place as the result of a given event.
Prerequisites	<ol style="list-style-type: none">1. Sensor is correctly connected (see section 5.5)2. Connection has been established from the sensor to the software (see section 10.1.1)3. The camera is configured / images are selected (see section 11.2)
Procedure	Any desired results can be assigned to an output. Any desired inputs can be configured as well.

11.21.2. Settings

Property	The following settings/results appear.
Process Time [ms]	Sensor processing time for the module
Module State	Error codes to give support in error diagnosis (see section 18.5)
Error Handling	This setting can be used to set performance of the properties when a linked event demonstrates an error status.

11.21.3. Configuration

The I/O unit module includes the following configuration options:

- IO Timings
- Digital IO 1
- Digital IO 2
- Digital IO 3
- Digital IO 4
- Digital IO 5
- Digital IO 6

The digital I/Os are originally preset as follows:

Digital IO	N0.	Type	Polarity	Mode	Linking/Function
	1	Output	Positive	PNP	Threshold, pixel count module
	2	Output	Positive	PNP	-
	3	Output	Positive	PNP	-
	4	Output	Positive	PNP	Process output
	5	Input	Positive	-	Trigger
	6	Output	Negative	Push-Pull	Flash output (external illumination)

11.21.3.1. IO Timings

Objective Time settings can be selected for the inputs and outputs.

Property

Process Time [ms]	Sensor processing time for the module
Module State	Error codes to give support in error diagnosis (see section 18.5)
Timing Unit	<p>Milliseconds / quadrature pulse</p> <p>If "Timing Unit" is set to quadrature pulse, all other time values must also be entered in pulses, and not in any unit of measure for time. The internal counter is triggered either by a millisecond tick or by quadrature pulses.</p>
Trigger Delay	<p>Delay time between the trigger signal and image acquisition can be set within a range of 0 to 10,000 ms.</p> <p>Sequence in Trigger mode with Trigger Delay</p> <p>Trigger Delay = 20 Output Hold Time = 0 Event 1 Delay = 0</p> <p>Time [ms]</p>

Property

Output Hold Time

Output hold time specifies the duration of the output signal. Output signal duration can be set within a range of 0 to 10,000 ms. **Note:** With an output hold time of 0 (default value), the output retains its status until a subsequent calculation causes its status to change.

Sequence in Trigger mode with Trigger Delay and Output Hold Time

Trigger Delay = 20
Output Hold Time = 20
Event 1 Delay = 0

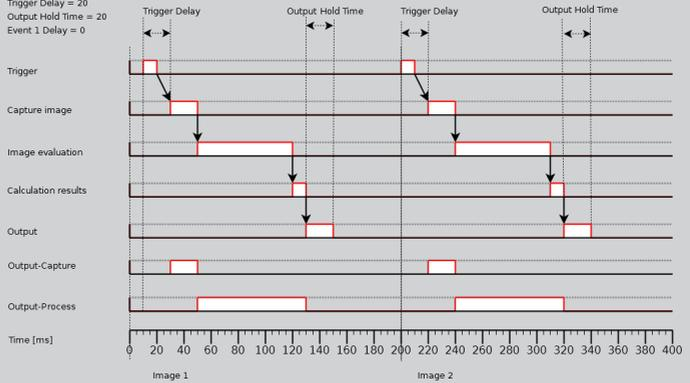

Event 1 to 4 Delay

Output signal delay can have a value within a range of 0 to 10,000 ms or pulses (in the case of a rotary encoder input). The output must be linked to the corresponding event delay to this end. Up to 4 different delays can be selected, which can be linked as often as desired to corresponding outputs.

Sequence in Trigger mode and Trigger Delay/Event Delay/Output Holdtime

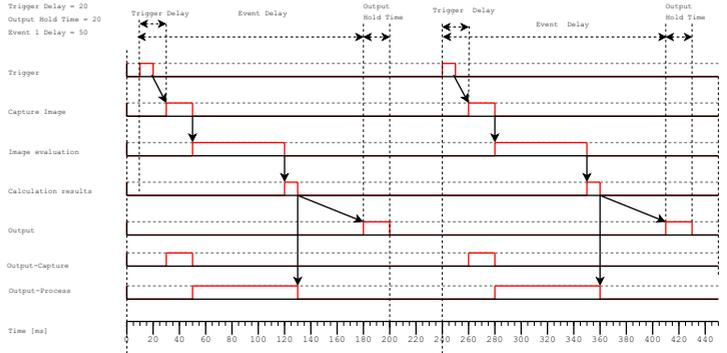

Property

Event 1 to 4
Delay

Note: In the trigger mode, the next trigger signal for renewed image recording might be generated although the sensor is still busy with image evaluation or calculation. In this case, the output process signal has not yet been reset to “1”, so that the trigger signal does not cause renewed image recording at the sensor. An “empty” image is generated which is subjected to the entire image processing sequence, thus leading to negative results. This assures that there’s a result for each and every trigger pulse.

Sequence in Trigger mode with Trigger-Queue and ignored Trigger

Trigger Delay = 0
Output Hold Time = 0
Event 1 Delay = 0

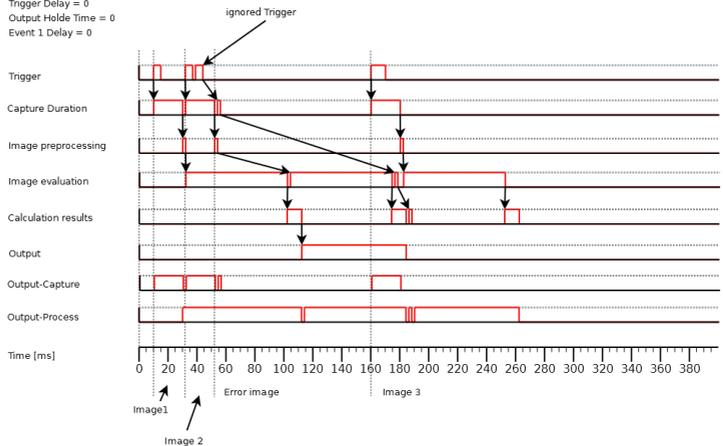

11.21.3.2. Digital I/Os 1 to 6 Sub-Module

Objective The digital inputs and outputs can be configured.

Property

Process Time [ms]	Sensor processing time for the module
Module State	Error codes to give support in error diagnosis (see section 18.5)
IO Value	The input or output is activated or deactivated.
IO Type	The type of input or output can be specified: <ul style="list-style-type: none"> • Type Nothing. • Type Input. • Type Output.
IO Logic	Output logic is specified. <ul style="list-style-type: none"> • Logic Positive. • Logic Negative.
IO Function	The function of the output is specified. <p>Output Fixed value or variable event from the application</p> <p>Output Flash Illumination output for external illumination</p> <p>Output Capture If the output signal is high, the sensor records an image. If a trigger pulse is generated during this time, an empty image is generated and an internal error occurs. This error image is forwarded to the downstream processes. It's assured that no trigger pulses are lost.</p> <p>Output Project Selection This output is used to acknowledge successful switching from one project to another. Further information is included in section 12.</p> <p>Input Level The input is at high level for as long as a signal is applied to the input. As soon as the signal is interrupted, the input is reset to low level.</p> <p>Input Edge The input is set to high level as soon as a positive edge is applied to the input. Thereafter, the input is reset to low level.</p> <p>Input Trigger The sensor generates an evaluation as soon as a trigger pulse is applied to the input. This input is exclusively responsible for image acquisition.</p> <p>Input Quadrature The input is used as a rotary encoder input. Note: In the case of a rotary encoder, two signals are read out which are out of phase with each other.</p>

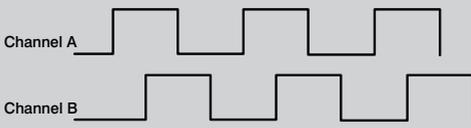
	 <p>Channel A</p> <p>Channel B</p> <p>These two signals have to be connected to two sensor pins, regardless of order. The selected pins have to be connected to Input Quadrature in weQube software. Furthermore, the timing unit has to be set to quadrature pulses under IO timings (see section 11.21.3.1). All IO timings are then displayed in pulses instead of milliseconds.</p> <p>Example: A further pin can now be used as a hardware trigger input and the number of pulses required to cause image recording after the hardware trigger signal has occurred can be entered to the trigger delay settings. You can also set up an event delay in order to specify after how many pulses certain outputs will be switched.</p> <p>Input Project Selection The input is used to change projects and reacts to the project change pulse sequence. Further information is included in section 12.</p>
Output Mode	<p>The polarity of the output is specified.</p> <ul style="list-style-type: none"> • PNP • NPN • Push-Pull
Event Link	<p>The output can be linked to one of the four 4 event delays. As a result, the output is switched with a delay amounting to the time selected under IO timings (see section 11.21.3.1).</p>

11.21.3.3. Error Handling

This setting can be used to set performance of the properties when a linked event demonstrates an error status.

Property

Individual texts can be displayed:

Substitute BOOL Types by	If this checkbox has been activated, all properties of the Boolean type are replaced by the active value, if the linked file type demonstrates an error.
--------------------------------	--

11.22. Device Display

11.22.1. Overview

- Objective** The display can be adapted to meet your individual needs.
- Prerequisites**
1. Sensor is correctly connected (see section 5.5)
 2. Connection has been established from the sensor to the software (see section 10.1.1)
 3. The camera is configured / images are selected (see section 11.2)
- Procedure** After the type of display has been specified, the desired values or results can be displayed depending on the selected setting.

11.22.2. Settings

Property The following settings/results appear.

Process Time [ms]	Sensor processing time for the module
Module State	Error codes to give support in error diagnosis (see section 18.5)

11.22.3. Configuration

The display module includes the following configuration options:

- Text
- Indication
- Numeric
- Match code
- Teach

11.22.3.1. Text

Objective Individual texts and specific results can be displayed:

Text 1	Line 1 can be entered statically, or it can be linked to a value in the software.
Text 2	Line 2 can be entered statically, or it can be linked to a value in the software.
Text 3	Line 3 can be entered statically, or it can be linked to a value in the software.
Text 4	Line 4 can be entered statically, or it can be linked to a value in the software.

11.22.3.2. Indication

Objective

Six different Boolean states can be displayed, for example output switching statuses.

Property

Indication 1	Link to the desired parameter.
Indication 2	Link to the desired parameter.
Indication 3	Link to the desired parameter.
Indication 4	Link to the desired parameter.
Indication 5	Link to the desired parameter.
Indication 6	Link to the desired parameter.

11.22.3.3. Numeric

Objective

Display a line of text and a numeric value, including a bar graph.

Property

Description	A descriptive text or any desired parameter can be entered.
Value	Link to the desired parameter

11.22.3.4. Match code

Property

Match code	Link to the desired match code results
------------	--

11.22.3.5. Teach

Objective

Up to six different parameters can be changed via the OLED menu. OLED menu → select “Teach” and then the corresponding number. After pressing the T key at the sensor, the currently ascertained value is accepted.

 Input Region	Linked
 Input Image	Linked
 Teach	<input checked="" type="checkbox"/> Linked 
Mode	Static
Threshold Low	64

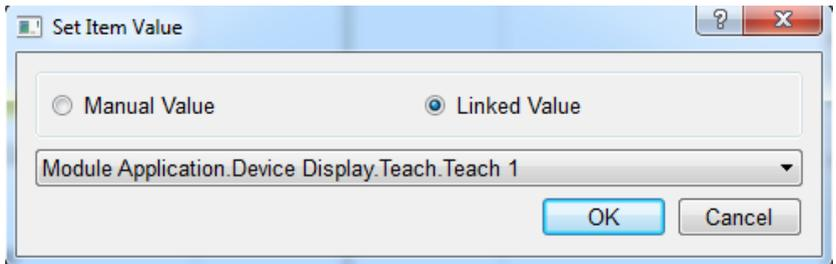

→ Teach and the corresponding number can then be selected at the OLED. After pressing the T key at the sensor, the currently ascertained value is accepted.

Property

Teach 1	Link to the desired parameter
Teach 2	Link to the desired parameter
Teach 3	Link to the desired parameter
Teach 4	Link to the desired parameter
Teach 5	Link to the desired parameter
Teach 6	Link to the desired parameter

11.22.4. Error Handling

This setting can be used to set performance of the properties when a linked event demonstrates an error status.

Property

Individual texts can be displayed:

Substitute BOOL Types by	If this checkbox has been activated, all properties of the Boolean type are replaced by the active value, if the linked file type demonstrates an error.
Substitute INT Types by	The numeric value can be specified which is used as a substitute value in the event of a linked data type which is faulty.
Substitute STRING Types by	The text is specified which is used as a substitute text, when the linked data type is faulty.

11.23. Device Indicator

11.23.1. Overview

- Objective** The indicator LEDs can be used to simplify the visualization of parameter statuses, for example whether or not objects are good or defective.
- Note** In order to use the indicator LEDs, select the flash light mode (see section 11.2.2). In continuous light mode the indicator LEDs are inactive in order to avoid interferences of the image.
- Prerequisites**
1. Sensor is correctly connected (see section 5.5)
 2. Connection has been established from the sensor to the software (see section 10.1.1)
 3. The camera is configured / images are selected (see section 11.2)
- Procedure** The red and green indicator LEDs included in the sensor's internal illumination can be assigned to events, so that they light up when the respective event occurs.

11.23.2. Settings

Property The following settings/results appear.

Process Time [ms]	Sensor processing time for the module
Module State	Error codes to give support in error diagnosis (see section 18.5)
Green Indicator Value	The green LED can be switched on or off statically. It can also be dynamically linked to other nodes signalling events
Red Indicator Value	The red LED can be switched on or off statically. It can also be dynamically linked to other nodes signalling events
Green Logic	Logic for the green LED can be edited. <ul style="list-style-type: none"> • Logic Positive • Logic Negative
Red Logic	Logic for the red LED can be edited. <ul style="list-style-type: none"> • Logic Positive • Logic Negative

11.23.3. Error Handling

This setting can be used to set performance of the properties when a linked event demonstrates an error status.

Property Individual texts can be displayed:

Substitute BOOL Types by	If this checkbox has been activated, all properties of the Boolean type are replaced by the active value, if the linked file type demonstrates an error.
--------------------------	--

11.24. Device Communication

11.24.1. Overview

- Objective** Sensor communication dictates how data can be transmitted to the sensor, and how the sensor itself transmits data.
- Prerequisites**
1. Sensor is correctly connected (see section 5.5)
 2. Connection has been established from the sensor to the software (see section 10.1.1)
- Procedure** Various communication options can be selected and the respective settings can be adapted. UDP or RS-232 can be selected in addition to Profinet, FTP server and client.

11.24.2. Settings

Property The following settings/results appear.

Process Time [ms]	Sensor processing time for the module
Module State	Error codes to give support in error diagnosis (see section 18.5)

11.24.3. Configuration

The communication module includes the following configuration options:

- Industrial Ethernet
- UDP
- RS-232
- FTP or SD Card

11.24.3.1. RS-232

Objective

Transmit current results and data via the RS-232 port.

Property

The following settings/results appear.

Process Time [ms]	Sensor processing time for the module
Module State	Error codes to give support in error diagnosis (see section 18.5)
Preamble	The characters specified here precede the output data.
Postamble	The characters specified here follow the output data.
Delimiter	The delimiter used to separate the individual data packets from each other is specified here.
Output	The preview of the output value is displayed, which consists of preamble, delimiter and postamble.
String Count	<p>The number of desired values to be transmitted is defined.</p> <p>String Count 1...8 The value can be entered statically or linked to a value. This value is then transmitted via the interface.</p>

11.24.3.2. Industrial Ethernet

Objective The Industrial Ethernet interface can be configured.

Property

Process-Time [ms]	Sensor processing time for the process steps
Module State	Error codes to give support in error diagnosis (see section “18.5. weQube Software Module States” on page 201)
Interface Type	Note concerning Profinet: Depending on the type of sensor, the corresponding interface type must be selected here.
Slot Count	The same slot which is used in the controller must be entered here.
Six Slots are available	
Slot 1	Set to project change as a default value. In order to be able to select a given project via the Profinet interface, the project name on the sensor’s micro SD card must be saved using the following format: “xx_testproject” (x: any whole number from 0 to 9). Example: 01_testproject. Up to 254 projects can be addressed via the Profinet interface. Note: Slot 1 cannot be changed manually. In order to change a project via the Profinet interface, you only need to enter the settings to the controller – the communication module is unnecessary to this end.
Slot 2	Set to Profinet state as a default value. A list of possible states can be found in the appendix in section “18.2. weQube status information” on page 197. Note: Slot 2 cannot be changed manually.
Slot 3-6	Freely configurable Process Time [ms] Sensor processing time for the process steps Module State Error codes for troubleshooting support (see section 18.6) Slot Number Corresponds to the controller’s slot number Module ID Number specified by the DDBF Submodule ID Number specified by the DDBF Data Size Volume of data which is transmitted or received Direction Specifies the direction of data transmission PL c to device or device to PL c Data Nodes Number of data packets

Property

Slot 3-6	<table border="1"><thead><tr><th data-bbox="468 161 669 699">Data type</th><th data-bbox="669 161 1085 699"></th></tr></thead><tbody><tr><td data-bbox="468 161 669 699"></td><td data-bbox="669 161 1085 699"><p>The following types of data are available for transmission to the controller:</p><ul style="list-style-type: none">• 16 Byte Input (4 DINT).• 16 Byte Input (4 REAL).• 1 Byte Input (8 BOOL).• 128 Byte Input (2 CHAR[64]).• 1024 Byte Input (1 CHAR[1024]).• 16 Byte Output (4 DINT).• 16 Byte Output (4 REAL).• 1 Byte Output (8 BOOL).• 128 Byte Output (2 CHAR[64]).• 32 byte input (2 CHAR[16])• 64 byte input (2 CHAR[32])• 256 byte input (2 CHAR[128])• 512 byte input (2 CHAR[256])• 32 byte output (2 CHAR[16])• 64 byte output (2 CHAR[32])• 256 byte output (2 CHAR[128])• 512 byte output (2 CHAR[256])</td></tr></tbody></table>	Data type			<p>The following types of data are available for transmission to the controller:</p> <ul style="list-style-type: none">• 16 Byte Input (4 DINT).• 16 Byte Input (4 REAL).• 1 Byte Input (8 BOOL).• 128 Byte Input (2 CHAR[64]).• 1024 Byte Input (1 CHAR[1024]).• 16 Byte Output (4 DINT).• 16 Byte Output (4 REAL).• 1 Byte Output (8 BOOL).• 128 Byte Output (2 CHAR[64]).• 32 byte input (2 CHAR[16])• 64 byte input (2 CHAR[32])• 256 byte input (2 CHAR[128])• 512 byte input (2 CHAR[256])• 32 byte output (2 CHAR[16])• 64 byte output (2 CHAR[32])• 256 byte output (2 CHAR[128])• 512 byte output (2 CHAR[256])
Data type					
	<p>The following types of data are available for transmission to the controller:</p> <ul style="list-style-type: none">• 16 Byte Input (4 DINT).• 16 Byte Input (4 REAL).• 1 Byte Input (8 BOOL).• 128 Byte Input (2 CHAR[64]).• 1024 Byte Input (1 CHAR[1024]).• 16 Byte Output (4 DINT).• 16 Byte Output (4 REAL).• 1 Byte Output (8 BOOL).• 128 Byte Output (2 CHAR[64]).• 32 byte input (2 CHAR[16])• 64 byte input (2 CHAR[32])• 256 byte input (2 CHAR[128])• 512 byte input (2 CHAR[256])• 32 byte output (2 CHAR[16])• 64 byte output (2 CHAR[32])• 256 byte output (2 CHAR[128])• 512 byte output (2 CHAR[256])				

Note: The sensor settings must correspond exactly to the controller settings. The GSDML file is available from the download area on our website at wenglor.com. The GSDML file is also included on the product CD provided with the sensor.

11.24.3.3. UDP

Objective

Configure the UDP interface (user datagram protocol).

Note: In the case of UDP, data are streamed from the sensor to the network without checking to determine whether or not the data is received or who receives it.

Property

The following settings/results appear.

Process Time [ms]	Sensor processing time for the module
Module State	Error codes to give support in error diagnosis (see section "18.5. weQube Software Module States" on page 201)
Preamble	The characters specified here precede the output data.
Postamble	The characters specified here follow the output data.
Delimiter	The delimiter used to separate the individual data packets from each other is specified here.
Output	The preview of the output value is displayed, which consists of preamble, delimiter and postamble.
String Count	The number of desired values to be transmitted is defined. String Count 1...8 The value can be entered statically or linked to a value. This value is then transmitted via the interface.

11.24.3.4. FTP or SD Card

Objective

Configure the FTP interface.

Files can be written from the sensor to a PC via an FTP server, for example in order to compile error images or to document all objects.

Prerequisite: A corresponding FTP server must be set up (see appendix “18.1. Setting up an FTP Server at a PC” on page 196), and adequate memory capacity must be available.

Alternatively, the files can also be saved to the SD card in the sensor.

Property

Process Time [ms]	Sensor processing time for the module	
Module State	Error codes to give support in error diagnosis (see section “18.5. weQube Software Module States” on page 201)	
Data Sink	<p>FTP The images can be saved to an FTP server within the network. The sensor functions as an FTP client in this case. Access data for the FTP server have to be saved along with the sensor settings (see section “10.1.1.4. Properties” on page 45).</p> <p>SD Card The respective images are saved to the SD card located in the sensor. Note: Memory capacity at the SD card is limited, which means that only a certain number images can be saved there. When the SD card is full, additional images to be saved are lost.</p>	
Blocking Mode	<p>The speed at which data are saved to an FTP server or the SD card varies. Saving may take longer than the evaluation process. As a result, some events might not be saved. For example, this could be the case when images are saved along with events.</p> <p>The evaluation process can be suspended until saving has been successfully completed. The blocking mode must be activated to this end (activate the check box).</p>	
Filename	<p>The filename consists of:</p> <p>Filename_consecutive number</p>	
Save Image Type	Before an image can be stored, its type must be defined.	
Save Image Compression	This setting defines whether the image is stored in uncompressed BMP format, or whether it should be stored in compressed JPG format. It is important to note if you using a compressed image it will come to quality losses. The compressed image should not be used later as an input image.	

Property

Image	Link to the desired image in the sensor
Observer	This Boolean value determines whether or not an image is saved. If this value is linked, the application can be set up such that, for example, only error images are saved. Network load is reduced as a result, and data are pre-filtered. If the Boolean value have the status “false” the image will be saved.
String:	
Process Time [ms]	Sensor processing time for the process steps
Module State	Error codes to give support in error diagnosis (see section “18.5. weQube Software Module States” on page 201)
Preamble	The characters specified here precede the output data.
Postamble	The characters specified here follow the output data.
Delimiter	The delimiter used to separate the individual data packets from each other is specified here.
Output	The preview of the output value is displayed, which consists of preamble, delimiter and postamble.
String Count	The number of desired values to be transmitted is defined. String Count 1...8 The value can be entered statically or linked to a value. This value is then transmitted via the interface.

11.24.4. Error Handling

This setting can be used to set performance of the properties when a linked event demonstrates an error status.

Property

Individual texts can be displayed:

Substitute BOOL Types by	If this checkbox has been activated, all properties of the Boolean type are replaced by the active value, if the linked file type demonstrates an error.
Substitute INT Types by	The numeric value can be specified which is used as a substitute value in the event of a linked data type which is faulty.
Substitute STRING Types by	The text is specified which is used as a substitute text, when the linked data type is faulty.

11.25. Module Statistics

11.25.1. Overview

- Objective** The application can be fine-tuned on the basis of statistical sensor data.
- Prerequisites**
1. Sensor is correctly connected (see section 5.5)
 2. Connection has been established from the sensor to the software (see section 10.1.1)
 3. The camera is configured / images are selected (see section 11.2)
- Procedure** Various statistical data can be calculated and displayed. Up to 100 most recently acquired values can be analyzed.

11.25.2. Settings in the Statistics Module

Property The following settings/results appear.

Process Time [ms]	Sensor processing time for the process steps
Module State	Error codes to give support in error diagnosis (see section 18.5)
Channel Count	Number of parameters which will be acquired for statistical purposes

Function Field

Insertion of the statistics field

	Statistical evaluations are displayed in a separate area.
---	---

Statistics window

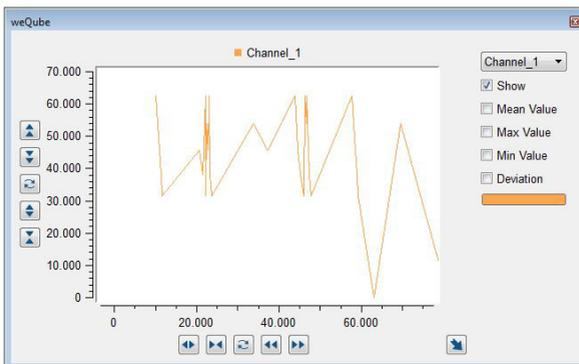

11.25.3. Configuration

Under channel count, the statistic module includes the configuration, which depends on the number of channels to be observed:

- Channel #1

11.25.3.1. Channel # 1

Objective

A certain value can be analyzed.

Property

The following settings/results are displayed:

Minimum	The lowest value of the most recently observed measured value results is indicated.
Maximum	The highest value of the most recently observed measured value results is indicated.
Mean	The arithmetic mean value is calculated from the most recently observed measured value results.
Standard Deviation	<p>Standard deviation is determined on the basis of the most recently observed measured value results. Standard deviation is the square root of the sum of the squared differences from the mean value divided by the number of values.</p> $s = \sqrt{\frac{1}{n} * \sum_{i=1}^n (x_i - \bar{x})^2}$
Trend	<p>All observed measured value results are subdivided into new and old events by means of the trend ratio. The arithmetic mean value is determined for the old, as well as for the new measured values. The difference between these arithmetic mean values is the trend.</p> <p>Note: If the trend is close to 0, the measured value has remained relatively constant during the observation time period.</p>
Good	The most recently observed measured value results are used to determine how often the measured value is within the specified tolerance. The good portion is indicated as a percentage of all analyzed values.
Input to Track	A variable application result can be linked to statistical evaluation.
Reset Statistic	All most recently observed measured value results, listed under result values, are deleted.

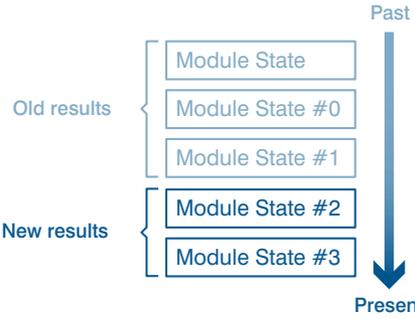
<p>Ratio for Trend</p>	<p>All observed measured value results are subdivided into older and newer results. The ratio of the number of older results to the number of newer results is indicated as the trend ratio. This ratio is set to 1 as a default value. Example of a trend ratio of 1.5 for 5 observed values</p> <div data-bbox="257 287 672 606" style="text-align: center;">  <p>The diagram illustrates the trend ratio calculation. It shows a vertical sequence of five 'Module State' boxes. The top three boxes, labeled 'Module State', 'Module State #0', and 'Module State #1', are grouped by a bracket and labeled 'Old results'. The bottom two boxes, labeled 'Module State #2' and 'Module State #3', are grouped by a bracket and labeled 'New results'. A blue arrow points downwards from the top, labeled 'Past' at the top and 'Present' at the bottom, indicating the direction of time.</p> </div> <p>This setting is used for the calculation of the trend. Note: The larger the trend ratio, the more influence individual outliers have on the trend.</p>
------------------------	---

12. Project Change via Digital I/O

Projects which have been saved to the sensor can also be selected and loaded without an Ethernet connection or an OLED display.

In order to be able to select a given project via the digital I/O interface, the project name on the sensor's micro SD card must be saved using the following format: „xxx_testproject“ (x: any whole number from 0 to 9). Example: 01_testproject. Up to 254 projects can be addressed via the digital I/O interface.

12.1. Software Settings

The “Input Project Selection” function must be assigned to one of the inputs in the Device I/O Unit module. This input is then used to change projects.

If the “Output Project Selection” function is also assigned to another output, weQube reads out the project number as a pulse sequence via this output. The number of pulses corresponds to the number of the previously selected project.

The settings of the two inputs and outputs must be identical for all projects, because problems might otherwise occur when changing projects.

12.2. Procedure

The sensor is switched to the project change mode by applying a voltage of greater than 7 V (high) to the previously selected input pin for a duration of T_{EN} .

Each positive edge is counted in the project change mode (one positive edge = project 1, two positive edges = project 2 etc.), until a voltage of less than 2 V (low) has been applied to the project change input for a duration of T_{DIS} .

If an output has been set up as a feedback output (project change output), the project selection is read out from this output using the number of pulses to identify the project number.

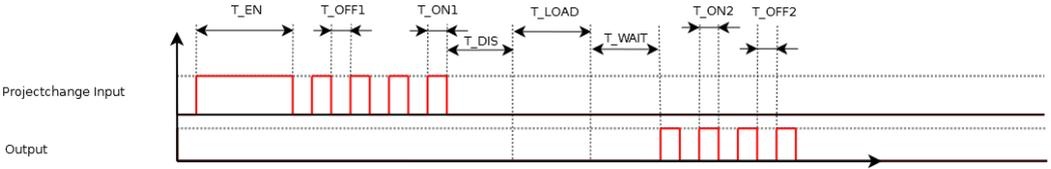

Designation	Typical	Min	Max
T_{EN}	2000 ms	1000 ms	5000 ms
T_{OFF1}	250 ms	100 ms	1000 ms
T_{ON1}	250 ms	100 ms	1000 ms
T_{DIS}	1000 ms	1000 ms	-
T_{LOAD}	12000 ms	10000 ms	15000 ms
T_{WAIT}	1000 ms	-	-
T_{OFF2}	250 ms	-	-
T_{ON2}	250 ms	-	-

13. Network Settings

The weQube is equipped with a web-based configuration interface which functions independent of the operating systems. You can configure the sensor conveniently at a standard web browser. (see section 18.4)

14. Web-Based Configuration

In order to operate the weQube at an Ethernet LAN, the sensor and the remote station, for example a computer, must be located in the same network. The sensor's IP address is set to 192.168.100.1, the subnet mask is set to 255.255.255.0 and the standard gateway is set to 192.168.100.254. The operating instructions always assume that these default values are used.

Further information on changing the IP address and deactivating the firewall – with reference to your operating system – can be found in the general instructions included on the weQube product page at: www.wenglor.com → Product World → Product search (Order no.) → Download → General instructions.

Note: It's not possible to access the sensor simultaneously with the software and via the website. If applicable, disconnect the sensor from the software before opening the website. Furthermore, under no circumstances should you enter settings simultaneously via the website and at the OLED display.

Note: If a DHCP server has been connected, it automatically assigns an IP address to the sensor. The assigned IP address can be viewed at the OLED display (see section 6.8.2) and entered to the address line in the browser, in order to open the sensor's website.

Note: The web interface has been tested with PC-based browsers. Error-free performance cannot be 100% assured for mobile devices.

14.1. Invoking the Administration Interface

Start the web browser. Enter the sensor's IP address to the address line in your browser and press the enter key. The IP address is preset to 192.168.100.1.

Example: `http://192.168.100.1/`

The "General Device" overview page and the sensor's live image are not password protected. A password prompt appears when other pages are accessed. The following user data are preset upon shipment from the factory.

User name: admin

Password: admin

The password can be changed in the "Device Settings" page.

14.2. Page Layout

The website is subdivided into 4 areas:

1. Language selection

The website can be changed from English (default language) to German with the language selection function.

2. Display

The current display appears on all pages just like it does at the sensor itself.

3. Category selection

The web-based settings are subdivided into five categories.

- **General device information:** overview page with general information regarding the weQube
- **Device settings:** network and display setting for the weQube, as well as sensor configuration and password change
- **Project:** project administration settings
- **Teach-in:** generate Teach+ files and teach characteristics in to the sensor
- **Live image:** the current sensor image is displayed

4. Page content

Depending on which category is selected, the corresponding page content is displayed.

14.3. Device, General

After a connection has been established, the “**Device, General**” overview page is displayed.



General product information

Part number	B50M002
Product version	1.0.0
Producer	wenglor sensoric GmbH
Description	weQube
Serial number	500014785
MAC Address	54:4a:05:09:00:08

Order number	The order number is the article number by means of which the weQube can be ordered from wenglor.
Product version	The product version is the sensor's version number.
Manufacturer	The manufacturer of the weQube is wenglor.
Description	<p>The description indicates the type of product. Differentiation is made amongst the following types:</p> <ul style="list-style-type: none">• weQube Decode• weQube Vision• weQube
Serial number	The serial number can be used to trace the product back to detailed manufacturing information.
MAC address	The sensor's MAC address is unique and is required for the identification of Ethernet products.

The following data are also displayed for Ethernet sensors:

Real-time Ethernet status	The status of the Ethernet connection is indicated: offline, online ...
Device name	A unique name can be freely assigned to each device via the Profinet controller. The device name appears in the first line of the display as well. If no name is assigned, ...

14.4. Device Settings

Network and display settings, the sensor configuration and password changes can be entered under device settings. The following screenshot shows the default settings.

The screenshot displays a web-based configuration interface for a device. It is organized into four main sections:

- Network Settings:** Contains radio buttons for "Get IP address automatically" (unselected) and "Use following IP addresses:" (selected). Below are input fields for "IP-address" (192.168.100.1), "Subnet mask" (255.255.255.0), and "Standard gateway" (192.168.100.254). A "Send" button is next to the Subnet mask field. At the bottom of this section are "Apply" and "Reset" buttons.
- Display settings:** Contains four dropdown menus: "Language" (Deutsch), "Rotate display" (OFF), "Display intensity" (Screensaver), and "Display mode" (Numeric).
- Configuration:** Contains two buttons: "Load from SD-Card" and "Save to SD-Card", both with "Send" buttons next to them.
- Webserver Password:** Contains a "Password" input field and a "Change" button.

1. Network settings

The IP address can be assigned automatically, or a specific IP address can be used. If a specific IP address is used, the following settings must be entered:

- IP address** Enter the sensor's IP address.
Note: The PC and the sensor have to use the same IP address (see section on network settings).
- Subnet mask** The subnet mask specifies the prefix length. It stipulates the number of bits at the beginning of the IP address for the network prefix.
- Standard gateway** Specifies the IP address of the gateway in order to be able to communicate beyond the boundaries of the subnet.

Warning: Error-free operation of the product can only be assured if correct network settings are entered via the web interface. If any incorrect entries are made, it may no longer be possible to contact the device within the network.

2. Network Reset

In the event of a network reset, the network settings are returned to their default values (see section 5.6). The network settings become effective after the sensor is restarted. The sensor settings remain unchanged.

3. Display Settings

Refer to section 6.4.2 for a description of the display settings.

4. Configuration

Refer to section 6.7 for a description of the sensor configuration.

5. Password

The password for the website can be changed here. An additional window appears at which a new password can be entered after the existing password has been successfully entered.

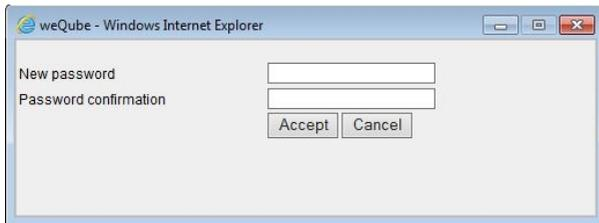

The screenshot shows a web browser window titled "weQube - Windows Internet Explorer". The main content area contains a form for changing a password. It has two text input fields: "New password" and "Password confirmation". Below these fields are two buttons: "Accept" and "Cancel".

14.5. Projects



The screenshot shows a "Project management" interface. It contains four rows of controls:

Current project	Undefined
Load project	--- ▾
Start project	---
Set start project	--- ▾

Projects saved to the SD card can be loaded, or can be selected as a start project.

14.6. Teach-In

Teach +		
Image Count	<input type="text" value="10"/>	<input type="button" value="Start"/>
		<input type="button" value="Cancel"/>
Teach-In		
Selection	<input type="text" value="Teach-In1"/>	<input type="button" value="Execute"/>

Refer to section 11.22.3.5 for a description of teach-in options.

14.7. Image

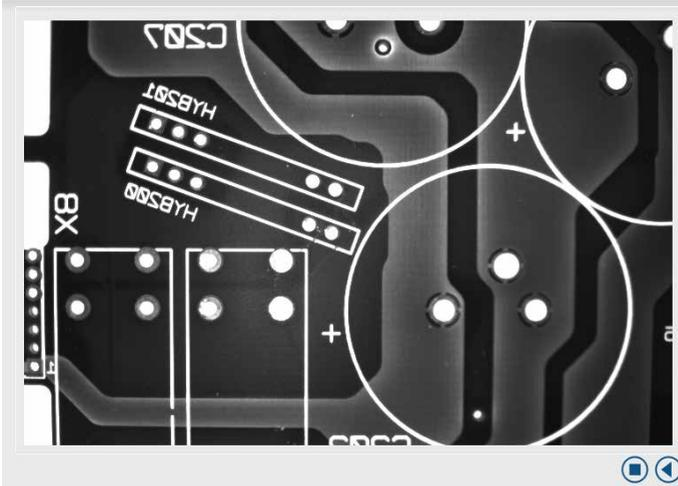

The current sensor image is displayed in the live image window. Display begins as soon as the “Live Image” tab is clicked. The live image can be frozen for purposes of error analysis by clicking the “Stop” button.

15. Maintenance Instructions

- This wenglor sensor is maintenance-free.
- It's advisable to clean the protective disc and to check screw joints, as well as plug connections and clamp connectors, at regular intervals.
- Do not use any solvents or cleaning agents which might damage the sensor.

16. Proper Disposal

wenglor sensoric GmbH does not accept the return of unusable or irreparable products. Respectively valid national waste disposal regulations apply to product disposal.

17. Exclusion of Liability

wenglor sensoric GmbH, hereinafter referred to as wenglor, makes explicit reference to the fact that the information contained in these operating instructions may be subject to continuous further development and technical changes. The operating instructions do not imply any guarantee from wenglor with regard to the described technical procedures or specific product characteristics. wenglor assumes no liability for printing errors or other inaccuracies contained in these operating instructions, unless wenglor was verifiably aware of such errors at the point in time at which the operating instructions were prepared. Furthermore, wenglor herewith explicitly informs the user that these operating instructions are only a general description of technical procedures whose implementation may not be suitable in all cases as described in this document.

Information included in these operating instructions is subject to change without notice. No part of this document may be duplicated or translated into any other languages, regardless of the utilized means, without prior written consent from wenglor sensoric GmbH.

wenglor sensoric GmbH
www.wenglor.com

18. Appendix

18.1. Setting up an FTP Server at a PC

Suitable software is required in order to set up an FTP server at a PC. Examples include:

- FileZilla Server
- Serv-U
- CesarFTP

A user must be created in the software, so that the FTP server knows who is permitted to access data.

Note: Avoid simple, overgeneralized passwords in order to provide your FTP server with adequate security.

You can add folders to your FTP server and specify access rules. These rules stipulate whether users are able to read, edit and/or deleted files.

After the server has been linked to the outside world, it can be reached via the Internet by making the following entry to your browser:

ftp:// + IP address assigned by the provider

Example:

ftp://99.123.12.34

The following access codes have to be entered in order to access the sensor's micro SD card:

User name: ftpuser

Password:

Note: In order to make it possible for the FTP server to accept incoming connections, it may be necessary to reconfigure the Windows firewall. Firewall configuration can be accessed under Control Panel → Windows-Firewall → Exceptions.

18.2. weQube status information

The following weQube status information may appear (see section “6.14. Status Information” on page 34).

Bit	Section	Signal	Description
0	General	Information	Busy
1		Warning	There is at least one bit set, level = Warning
2		Critical Error	There is at least one bit set, level = Critical Error
3		Fatal Error	There is at least one bit set, level = Fatal Error
4		reserved	for future use, value=0
5		reserved	for future use, value=0
6	Peripheral	TCP/IP	There is an error concerning the TCP/IP socket
7		UDP	There is an error concerning the UDP socket
8		Industrial Ethernet	There is an error concerning industrial ethernet
9		Camera	There is an error concerning the built in image chip
10		Digital IO	There is an error concerning the built in digital io stage or the rotary decoder
11		Focus & Illumination	There is an error concerning the built in Focus&Illumination controller
12		UART	There is an error concerning the UART device
13		reserved	for future use, value=0
14	Memory	Flash	There is an error concerning the flash access
15		RAM	There is an error concerning the RAM access
16		SD-Card	There is an error concerning the sd-card access, 1 if not mounted
17		File access	There is an error concerning a general file access
18		Compatibility	There is an error concerning the version of the loaded project
19		reserved	for future use, value=0
20	Temperature	Over temperature	The inside temperature is higher than a predefined level
21		Under temperature	The inside temperature is lower than a predefined level
22		reserved	for future use, value=0
23		reserved	for future use, value=0
24	Image Processing	Sequencing	There is an error concerning IData vision engine
25		Processing	There is an error concerning a vision module
26		Trigger	There is an error concerning HW trigger
27		reserved	for future use, value=0
28	reserved	reserved	for future use, value=0
29		reserved	for future use, value=0
30		reserved	for future use, value=0
31		reserved	for future use, value=0

18.3. Coordinate system

By use of coordinates, the position inside a coordinate system is defined uniquely (surface, volume etc.) The sensor operates in a predominantly two-dimensional image in which a point P (X, Y) is defined by the X and Y components.

We distinguish three Cartesian coordinate systems with different reference points.

- Image sensor coordinate system
- Image coordinate system
- Input coordinate system

All the coordinate systems follow the definition of a right-handed coordinate system.

18.3.1. Right handed coordinate system

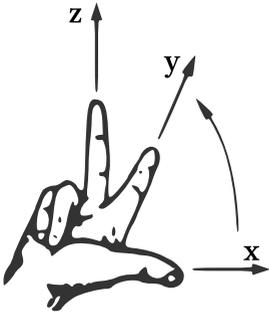

Source: Wikipedia

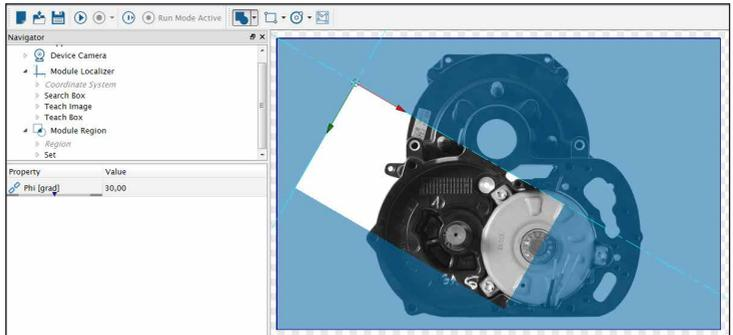

Note: The right handed coordinate system is rotated 180° by the X-axis to follow a popular representation.

- X-axis (red)
- Y-axis (green)
- Mathematical positive direction of rotation

18.3.2. Image sensor coordinate system

The image sensor coordinate system represents the coordinates on the real CMOS chip area.

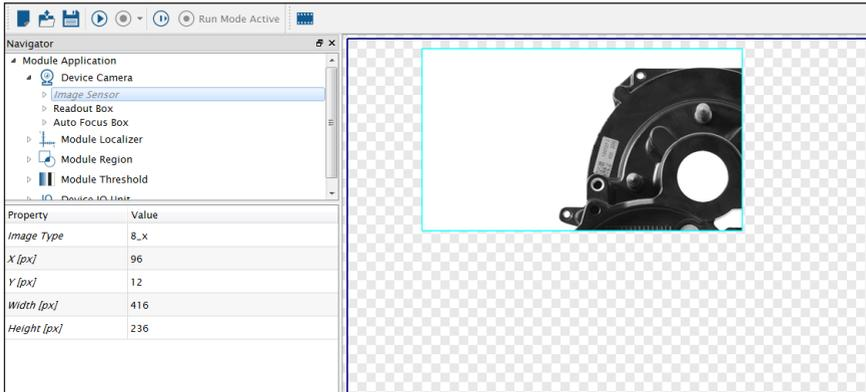

- The coordinate origin is placed in the top left of the image sensor (the blue rectangle represents the light sensitive area of the image sensor)
- X-axis (positive counting to the right)
- Y-axis (positive counting to the bottom)

18.3.3. Image coordinate system

The image coordinate system is related to the image sensor origin.

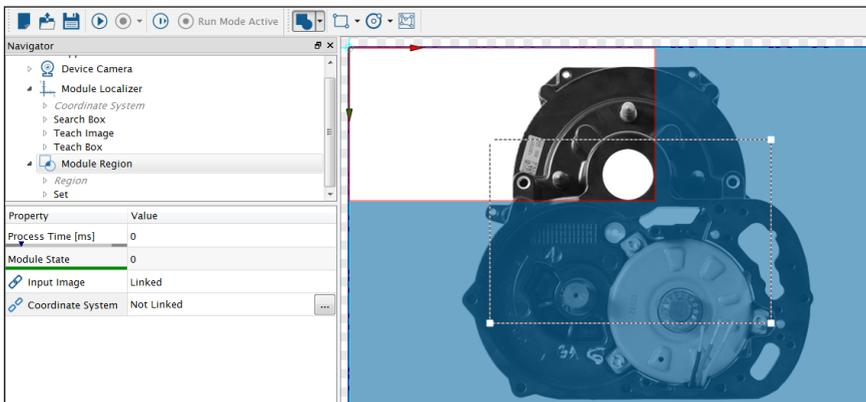

- The coordinate origin is placed in the top left of the image sensor
- X-axis (positive counting to the right)
- Y-axis (positive counting to the bottom)

18.3.4. Input coordinate system

The input coordinate system is related to the image origin and can be placed and rotated individually.

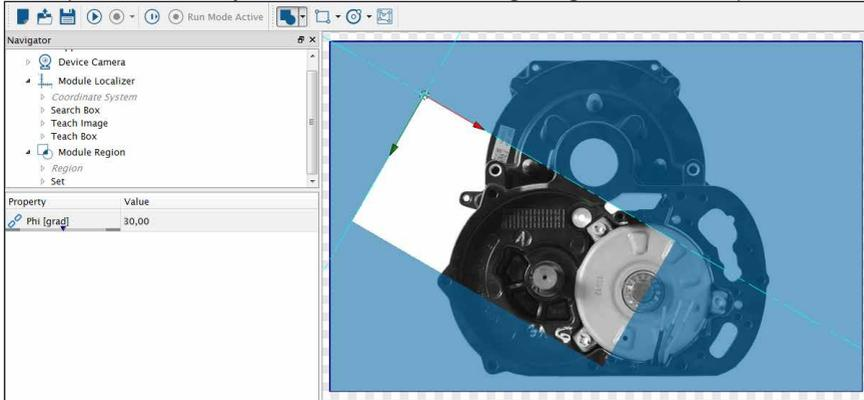

- The coordinate origin is initially placed in the top left of the image
- X-axis (positive counting to the right)
- Y-axis (positive counting to the bottom)

Note: In case where an input coordinate system is linked against an output coordinate system it, behaves as an output coordinate system only. Output coordinates systems can not be edited, and follow the calculated values (e.g. tracking of regions and other tools).

18.4. Network Settings

Protocol	Port	Description
TCP/IP	32001	This port is used for Communication with weQube by the LIMA-Protocol. This port is selectable. It is not allowed to use the ports mentioned below.
UDP	32002	This port is used to send the device state as a subnet broadcast. Process data configured in Module Communication is sent out in the same way. It is not allowed to change this port.
UDP	32003	This port is used to send LIMA commands to the weQube. Attention: UDP can transfer a maximum of 65535 byte. It is easier to send commands with more data by TCP/IP. This port is used to send short commands like <T/> to the weQube in cases where trigger mode is used. It is not allowed to change this port.
UDP	32004	This port is used by the weQube to reply to commands that are received by port 32003. It is not allowed to change this port.
FTP	21	This port is reserved for the integrated ftp server. It is not allowed to change this port.
TELNET	23	This port is reserved for the built in telnet access. This access is reserved for internal purpose. It is not allowed to change this port.
HTTP	80	This port is reserved for the built in HTTP webserver. It is not allowed to change this port.

18.5. weQube Software Module States

There is a description in the weQube manual in section 9. Here is some additional information.

If you need further license keys for your weQube do the following:

1. Open your weQube PC application and use the "Connect to Device" button.
2. Note the MAC address of your weQube sensor down (Device List).
3. Double click the related sensor entry to establish a connection to the device.
4. Open the license information by pressing the menu entry "Help -> Licenses".
5. Select the module you wanna license and press the "Generate" button to save the Hardware File.
6. Send the file to wenglor by e-mail.

Attention: If you have more than one weQube send one e-mail per weQube.

Write always the following e-mail subject: weQube License Request for ##:##:##:##:##:##

7. Replace the ##:##:##:##:##:## in the subject with the MAC address of your weQube.

Example: weQube License Request for 54:4A:05:07:13:13

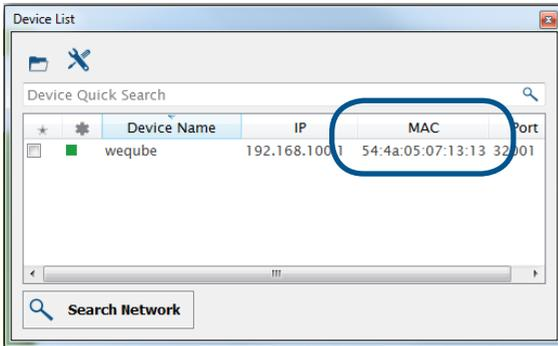

Image 1: MAC Address in Device List

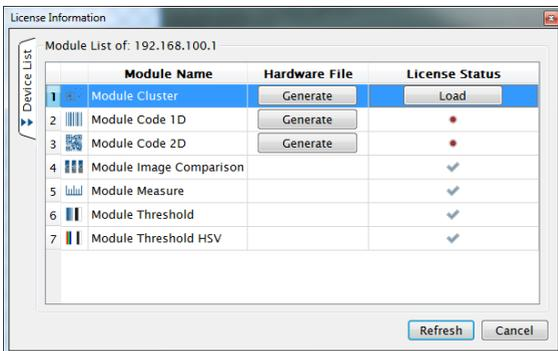

Image 2: License window

How to install a license file:

1. For every license request you get an e-mail with one validation file. Do steps 2 to 6 for each validation file.
2. Save the validation file to the PC the weQube application is installed on.
3. Open your weQube PC application and use the “Connect to Device” button.
4. Open the license information by pressing the menu entry “Help → Licenses”.
5. Select the module you want to license and press the “Load” button to load the validation file you previously saved.
6. The new license will be activate by adding the related module from the tool box to your project or simply reload the active project.

18.6. weQube Software Module States

There are specific states for each software module, which can be displayed in each module’s module state.

Error Code weQube

0	no error
1001	undefined
1010	Input value error
1011	Return value error
1012	Internal data error
1020	alignment error
1030	Function not implemented
1040	Image not linked
1050	Invalid operation
1060	Module Timeout
1098	Exception, bad allocation
1099	Exception
1100	Module unlicensed
1101	Module init failed
1102	Module not taught
10000-19999	internal error of Data structure
21201	Wrong type of control parameter: 1
21202	Wrong type of control parameter: 2
21203	Wrong type of control parameter: 3
21204	Wrong type of control parameter: 4
21205	Wrong type of control parameter: 5
21206	Wrong type of control parameter: 6
21207	Wrong type of control parameter: 7
21208	Wrong type of control parameter: 8
21209	Wrong type of control parameter: 9
21210	Wrong type of control parameter: 10
21211	Wrong type of control parameter: 11
21212	Wrong type of control parameter: 12
21213	Wrong type of control parameter: 13
21214	Wrong type of control parameter: 14
21215	Wrong type of control parameter: 15
21216	Wrong type of control parameter: 16
21217	Wrong type of control parameter: 17
21218	Wrong type of control parameter: 18
21219	Wrong type of control parameter: 19

21220	Wrong type of control parameter: 20
21301	Wrong value of control parameter: 1
21302	Wrong value of control parameter: 2
21303	Wrong value of control parameter: 3
21304	Wrong value of control parameter: 4
21305	Wrong value of control parameter: 5
21306	Wrong value of control parameter: 6
21307	Wrong value of control parameter: 7
21308	Wrong value of control parameter: 8
21309	Wrong value of control parameter: 9
21310	Wrong value of control parameter: 10
21311	Wrong value of control parameter: 11
21312	Wrong value of control parameter: 12
21313	Wrong value of control parameter: 13
21314	Wrong value of control parameter: 14
21315	Wrong value of control parameter: 15
21316	Wrong value of control parameter: 16
21317	Wrong value of control parameter: 17
21318	Wrong value of control parameter: 18
21319	Wrong value of control parameter: 19
21320	Wrong value of control parameter: 20
21350	Wrong value of component (see reset_obj_db())
21351	Wrong value of gray value component (see reset_obj_db())
21401	Wrong number of values of control parameter: 1
21402	Wrong number of values of control parameter: 2
21403	Wrong number of values of control parameter: 3
21404	Wrong number of values of control parameter: 4
21405	Wrong number of values of control parameter: 5
21406	Wrong number of values of control parameter: 6
21407	Wrong number of values of control parameter: 7
21408	Wrong number of values of control parameter: 8
21409	Wrong number of values of control parameter: 9
21410	Wrong number of values of control parameter: 10
21411	Wrong number of values of control parameter: 11
21412	Wrong number of values of control parameter: 12
21413	Wrong number of values of control parameter: 13
21414	Wrong number of values of control parameter: 14
21415	Wrong number of values of control parameter: 15
21416	Wrong number of values of control parameter: 16
21417	Wrong number of values of control parameter: 17
21418	Wrong number of values of control parameter: 18
21419	Wrong number of values of control parameter: 19
21420	Wrong number of values of control parameter: 20
21500	Number of input objects too big
21501	Wrong number of values of object parameter: 1
21502	Wrong number of values of object parameter: 2
21503	Wrong number of values of object parameter: 3
21504	Wrong number of values of object parameter: 4
21505	Wrong number of values of object parameter: 5
21506	Wrong number of values of object parameter: 6
21507	Wrong number of values of object parameter: 7
21508	Wrong number of values of object parameter: 8

21509	Wrong number of values of object parameter: 9
21510	Number of output objects too big
22000	Wrong specification of parameter (error in file: xxx.def)
22001	Initialize Halcon: reset_obj_db(Width,Height,Components)
22002	Used number of symbolic object names too big
22003	No license found
22004	Lost connection to license server
22005	No modules in license (no VENDOR_STRING)
22006	No license for this operator
22007	Time zone offset from GMT is > 24 hours
22008	Vendor keys do not support this platform
22009	Bad vendor keys
22010	Unknown vendor key type
22011	malloc() call failed
22012	Vendor keys have expired
22013	Second call to lc_init() (multiple jobs), and vendor keys do not support multiple jobs
22014	Vendor key data not supplied
22015	Imclient.h/liblmgr.a version mismatch
22016	Networking software not available on this machine
22017	Old vendor keys supplied
22018	License key in license file does not match other data in file
22019	Encryption handshake with daemon failed
22020	'key' structure is incorrect type, or feature Err:520 NULL, or num_licenses Err:520 0
22021	System clock has been set back. This error can only occur when the FEATURE line contains an expiration date
22022	Version argument is invalid floating point format
22023	License server busy starting another copy of itself -0 retry
22024	Cannot establish a connection with a license server
22025	Feature is queued. lc_status will determine when it is available
22026	Vendor keys do not support this function
22027	Checkout request filtered by the vendor-defined filter routine
22028	Checkout exceeds MAX specified in options file
22029	All licenses in use
22030	No license server specified for counted license
22031	Can not find feature in the license file
22032	Server has different license file than client -0 client's license has feature, but server's does not
22033	License file does not support a version this new
22034	This platform not authorized by license -0 running on platform not included in PLATFORMS list
22035	License server busy -0 the request should be retried (This is a rare occurrence)
22036	could not find license.dat
22037	Invalid license file syntax
22038	Cannot connect to a license server
22039	No TCP license service exists
22040	No socket connection to license manager server
22041	Invalid host
22042	Feature has expired
22043	Invalid date format in license file
22044	Invalid returned data from license server
22045	Cannot find SERVER hostname in network database
22046	Cannot read data from license server

22047	Cannot write data to license server
22048	Error in select system call
22049	Feature checkin failure detected at license
22050	Users are queued for this feature
22051	License server does not support this version of this feature
22052	Request for more licenses than this feature supports
22053	Cannot read /dev/kmem
22054	Cannot read /vmunix
22055	Cannot find ethernet device
22056	Cannot read license file
22057	Feature not yet available (wrong time/date set?)
22058	No such attribute
22059	Clock difference too large between client and server
22060	Feature database corrupted in daemon
22061	Duplicate selection mismatch for this feature
22062	User/host on EXCLUDE list for feature
22063	User/host not on INCLUDE list for feature
22064	Feature was never checked out
22065	Invalid FLEXlm key data supplied
22066	Clock setting check not available in daemon
22067	Date too late for binary format
22068	FLEXlm not initialized
22069	Server did not respond to message
22070	Request rejected by vendor-defined filter
22071	No FEATURESET line present in license file
22072	Incorrect FEATURESET line in license file
22073	Cannot compute FEATURESET line
22074	socket() call failed
22075	setsockopt() failed
22076	Message checksum failure
22077	Cannot read license file from server
22078	Not a license administrator
22079	Imremove request too soon
22080	Attempt to read beyond the end of LF path
22081	SY\$_SETIMR call failed
22082	Internal FLEXlm Error -0 Please report to Globetrotter Software
22083	FLEXadmin API functions not available
22084	Invalid PACKAGE line in license file
22085	Server FLEXlm version older than client's
22086	Incorrect number of USERS/HOSTS INCLUDED in options file – see server log
22087	Server doesn't support this request
22088	This license object already in use
22089	Future license file format or misspelling in license file
22090	Feature removed during Imrread or wrong SERVER line hostid
22091	This feature is available in a different license pool
22092	Network connect to THIS_HOST failed
22093	Server node is down or not responding
22094	The desired vendor daemon is down
22095	The decimal format license is typed incorrectly
22096	All licenses are reserved for others
22097	Terminal Server remote client not allowed
22098	Cannot borrow that long

22099	License server out of network connections
22100	Wrong index for output object parameter
22101	Wrong index for input object parameter
22102	Wrong index for image object (too big or too small)
22103	Wrong number region/image component (see: HGetComp)
22104	Wrong relation name
22105	Access to undefined gray value component
22106	Wrong image width
22107	Wrong image height
22108	Undefined gray value component
22200	Inconsistent data of data base (typing)
22201	Wrong index for input control parameter
22202	Data of data base not defined (internal error)
22203	Number of operators too big
22205	User extension not properly installed
22206	Number of packages too large
22207	No such package installed
22300	Dongle not attached, or can't read dongle
22301	Missing Dongle Driver
22302	FLEXlock checkouts attempted
22303	SIGN= attribute required
22304	CRO not supported for this platform
22305	BORROW failed
22306	BORROW period has expired
22307	FLOAT_OK license must have exactly one dongle hostid
22308	Unable to delete local borrow info
22309	Support for returning aborrowed license early is not enabled
22310	Error returning borrowed license on server
22311	Error when trying to checkout just a PACKAGE(BUNDLE)
22312	Composite Hostid not initialized
22313	An item needed for Composite Hostid missing or invalid
22314	Borrowed license doesn't match any known server license
22315	Error enabling event log
22316	Event logging is disabled
22317	Error writing to event log
22318	Timeout
22319	Bad message command
22320	Error writing to socket, peer has closed socket
22321	Attempting to generate version specific license tied to a single hostid, which is composite
22322	Version-specific signatures are not supported for uncounted licenses
22323	License template contains redundant signature specifiers
22324	Invalid V71_LK signature
22325	Invalid V71_SIGN signature
22326	Invalid V80_LK signature
22327	Invalid V80_SIGN signature
22328	Invalid V81_LK signature
22329	Invalid V81_SIGN signature
22330	Invalid V81_SIGN2 signature
22331	Invalid V84_LK signature
22332	Invalid V84_SIGN signature
22333	Invalid V84_SIGN2 signature
22334	License key required but missing from the license certificate

22335	Bad AUTH= signature
22336	TS record invalid
22337	Cannot open TS
22338	Invalid Fulfillment record
22339	Invalid activation request received
22340	No fulfillment exists in trusted storage which matches the request
22341	Invalid activation response received
22342	Can't return the fulfillment
22343	Return would exceed max count(s)
22344	No repair count left
22345	Specified operation is not allowed
22346	User/host on EXCLUDE list for entitlement
22347	User/host not in INCLUDE list for entitlement
22348	Activation error
22349	Invalid date format in trusted storage
22350	Message encryption failed
22351	Message decryption failed
22352	Bad filter context
22353	SUPERSEDE feature conflict
22354	Invalid SUPERSEDE_SIGN syntax
22355	SUPERSEDE_SIGN does not contain a feature name and license signature
22356	ONE_TS_OK is not supported in this Windows Platform
22357	Internal error -178
22358	Only one terminal server remote client checkout is allowed for this feature
22359	Internal error -180
22360	Internal error -181
22361	Internal error -182
22362	More than one ethernet hostid not supported in composite hostid definition
22363	The number of characters in the license file paths exceeds the permissible limit
22364	Invalid TZ keyword syntax
22365	Invalid time zone override specification in the client
22366	The time zone information could not be obtained
22367	License client time zone not authorized for license rights
22368	Invalid syntax for VM_PLATFORMS keyword
22369	Feature can be checked out from physical machine only
22370	Feature can be checked out from virtual machine only
22371	Vendor keys do not support Virtualization feature
22372	Checkout request denied as it exceeds the MAX limit specified in the options file
22373	Binding agent API -0 Internal error
22374	Binding agent communication error
22375	Invalid Binding agent version
22452	HALCON id out of range
22800	Wrong hardware knowledge file format
22801	Wrong hardware knowledge file version
22802	Error while reading the hardware knowledge
22803	Error while writing the hardware knowledge
22804	Tag in hardware knowledge file not found
22805	No cpu information in hardware knowledge file found
22806	No aop information in hardware knowledge file found
22807	No aop information for this HALCON variant found
22808	No aop information for this HALCON architecture found
22809	No aop information for specified Operator found

22810	Unknown aop model
22811	Wrong tag derivate in hardware knowledge file
22812	Internal error while processing hardware knowledge
22813	Optimizing aop was canceled
22830	Wrong access to global variable
22831	Used global variable does not exist
22832	Used global variable not accessible via GLOBAL_ID
22835	Halcon server to terminate is still working on a job
22837	No such HALCON software agent
22838	Hardware check for parallelization not possible on a single-processor machine
22839	Sequential HALCON does not support parallel hardware check (use Parallel HALCON instead)
22840	Initialization of agent failed
22841	Termination of agent failed
22842	Inconsistent hardware description file
22843	Inconsistent agent information file
22844	Inconsistent agent knowledge file
22845	The file with the parallelization information does not match to the currently HALCON version/revision
22846	The file with the parallelization information does not match to the currently used machine
22847	Inconsistent knowledge base of HALCON software agent
22848	Unknown communication type
22849	Unknown message type for HALCON software agent
22850	Error while saving the parallelization knowledge
22851	Wrong type of work information
22852	Wrong type of application information
22853	Wrong type of experience information
22854	Unknown name of HALCON software agent
22855	Unknown name and communication address of HALCON software agent
22856	cpu representative (HALCON software agent) not reachable
22857	cpu refuses work
22858	Description of scheduling resource not found
22859	Not accessible function of HALCON software agent
22860	Wrong type: HALCON scheduling resource
22861	Wrong state: HALCON scheduling resource
22862	Unknown parameter type: HALCON scheduling resource
22863	Unknown parameter value: HALCON scheduling resource
22864	Wrong post processing of control parameter
22867	Error while trying to get time (time query)
22868	Error while trying to get the number of processors
22869	Error while accessing temporary file
22900	Error while forcing a context switch
22901	Error while accessing the cpu affinity
22902	Error while setting the cpu affinity
22950	Wrong synchronization object
22952	Wrong thread object
22953	Input Object was not initialized
22954	Input control parameter is not initialized
22955	Output Object parameter is not initialized
22956	Output control parameter is not initialized
22970	creation of pthread failed
22971	pthread-detach failed

22972	pthread-join failed
22973	Initialization of mutex variable failed
22974	Deletion of mutex variable failed
22975	Lock of mutex variable failed
22976	Unlock of mutex variable failed
22977	failed to signal pthread condition variable
22978	failed to wait for pthread condition variable
22979	failed to init pthread condition variable
22980	failed to destroy pthread condition variable
22981	failed to signal event
22982	failed to wait for an event
22983	failed to init an event
22984	failed to destroy an event
22985	failed to create a tsd key
22986	failed to set a tsd key
22987	failed to get a tsd key
22988	failed to free a tsd key
22989	aborted waiting at a barrier
22990	'Free list' is empty while scheduling
22991	Communication partner not checked in
22992	you can not start the communication system while running it
22993	Communication partner not checked in
23010	Region completely outside of the image domain
23011	Region (partially) outside of the definition range of the image
23012	Intersected definition range region / image empty
23013	Image with empty definition range (=> no gray values)
23014	No common image point of two images
23015	Wrong region for image (first row < 0)
23016	Wrong region for image (column in last row >= image width)
23017	Number of images unequal in input parameters
23018	Image height too small
23019	Image width too small
23020	Internal error: multiple call of HRLInitSeg()
23021	Internal error: HRLSeg() not initialized
23022	Wrong size of filter for Gauss
23033	Filter size exceeds image size
23034	Filter size have to be odd
23035	Filter is too big
23036	Input region is empty
23040	Row value of a coordinate > $2^{15}-1$
23041	Row value of a coordinate < -2^{15}
23042	Column value of a coordinate > $2^{15}-1$
23043	Column value of a coordinate < -2^{15}
23100	Wrong segmentation threshold
23101	Unknown feature
23102	Unknown gray value feature
23103	Internal error in HContCut
23104	Error in HContToPol: distance of points too big
23105	Error in HContToPol: contour too long
23106	Too many rows (IPLImageTransform)
23107	Scaling factor = 0.0 (IPLImageScale)
23108	Wrong range in transformation matrix

23109	Internal error in IPvof: no element free
23110	Number of input objects is zero
23111	At least one input object has an empty region
23112	Operation allowed for rectangular images 2**n only
23113	Too many relevant points (IPHysteresis)
23114	Number of labels in image too big
23115	No labels with negative values allowed
23116	Wrong filter size (too small ?)
23117	Images with different image size
23118	Target image too wide or too far on the right
23119	Target image too narrow or too far on the left
23120	Target image too high or too far down
23121	Target image too low or too far up
23122	Number of channels in the input parameters are different
23123	Wrong color filter array type
23124	Wrong color filter array interpolation
23125	Homogeneous matrix does not represent an affine transformation
23126	Inpainting region too close to the image border
23127	Source and destination differ in size
23128	To many Features
23129	Reflection axis undefined
23131	Concurrence Matrix: too little columns for quantisation
23132	Concurrence Matrix: too little rows for quantisation
23133	Wrong number of columns
23134	Wrong number of rows
23135	Number has too many digits
23136	Matrix is not symmetric
23137	Matrix is too big
23138	Wrong structure of file
23139	Lesser than 2 matrices
23140	Not enough memory
23141	Can not read the file
23142	Can not open file for writing
23143	Too many lookup table colors
23145	Too many Hough points (lines)
23146	Target image has got wrong height (not big enough)
23147	Wrong interpolation mode
23148	Region not compact or not connected
23170	Wrong filter index for filter size 3
23171	Wrong filter index for filter size 5
23172	Wrong filter index for filter size 7
23173	Wrong filter size; only 3/5/7
23175	Number of suitable pixels too small to reliably estimate the noise
23200	Different number of entries/exits in HContCut
23250	Wrong XLD type
23252	Internal error: border point is set to FG
23253	Internal error: maximum contour length exceeded
23254	Internal error: maximum number of contours exceeded
23255	Contour too short for fetch_angle_xld
23256	Regression parameters of contours already computed
23257	Regression parameters of contours not yet entered! Please compute them by calling regress_cont_xld

23258	Data base: XLD object has been deleted
23259	Data base: object has no XLD-ID
23260	Internal error: wrong number of contour points allocated
23261	Contour attribute not defined
23262	Ellipse fitting failed
23263	Circle fitting failed
23264	All points classified as outliers (ClippingFactor too small)
23265	Quadrangle fitting failed
23266	No points found for at least one side of the rectangle
23267	A contour point lies outside of the image
23274	Not enough valid points for fitting the model
23275	No ARC/INFO world file
23276	No ARC/INFO generate file
23278	Unexpected end of file while reading DXF file
23279	Cannot read DXF-group code from file
23280	Inconsistent number of attributes per point in DXF file
23281	Inconsistent number of attributes and names in DXF file
23282	Inconsistent number of global attributes and names in DXF file
23283	Cannot read attributes from DXF file
23284	Cannot read global attributes from DXF file
23285	Cannot read attribute names from DXF file
23286	Wrong generic parameter name
23289	Internal DXF I/O error: Wrong data type
23290	Isolated point while contour merging
23291	Constraints (MaxError/MaxDistance) cannot be fulfilled
23300	Syntax error in file for training
23301	Maximum number of attributes per example exceeded
23302	Not possible to open file for training
23303	Too many data sets for training
23304	Wrong key for data for training
23305	Too many examples for one data set for training
23306	Too many classes
23307	Maximum number of cuboids exceeded
23308	Not possible to open classifier's file
23309	Error while saving the classifier
23310	Not possible to open protocol file
23311	Classifier with this name is already existent
23312	Maximum number of classifiers exceeded
23313	Name of classifier is too long, ≥ 20
23314	Classifier with this name is not existent
23315	Current classifier is not defined
23316	Wrong id in classification file
23317	The version of the classifier is not supported
23318	Serialized item does not contain a valid classifier
23330	Wrong covariance initialization
23331	The version of the GMM training samples is not supported
23332	Wrong training sample format
23333	Invalid file format for Gaussian Mixture Model (GMM)
23334	The version of the Gaussian Mixture Model (GMM) is not supported
23335	Internal error while training the GMM
23336	Singular covariance matrix
23337	No samples for at least one class

23338	Too few samples for at least one class
23340	GMM has not been trained yet
23341	No training samples stored in the classifier
23342	Serialized item does not contain a valid Gaussian Mixture Model (GMM)
23350	Unknown output function
23351	Target vector not in 0-1 encoding
23352	No training samples stored in the classifier
23353	Invalid file format for MLP training samples
23354	The version of the MLP training samples is not supported
23355	Wrong training sample format
23356	MLP is not a classifier; use OutputFunction = 'softmax' in create_class_mlp
23357	Invalid file format for multilayer perceptron (MLP)
23358	The version of the multilayer perceptron (MLP) is not supported
23359	Wrong number of image channels
23360	Number of MLP parameters too large
23361	Serialized item does not contain a valid multilayer perceptron (MLP)
23370	Wrong number of image channels
23371	A look-up table can be build only for a 2 or 3 channel classifier
23372	Cannot create a look-up table. Please choose a larger 'bit_depth' or select 'fast' for 'class_selection'.
23380	No training samples stored in the classifier
23381	Invalid file format for SVM training samples
23382	The version of the SVM training samples is not supported
23383	Wrong training sample format
23384	Invalid file format for support vector machine (SVM)
23385	The version of the support vector machine (SVM) is not supported
23386	Wrong class
23387	Nu was chosen too big
23388	SVM training failed
23389	Old SVM and new SVM do not match
23390	SVM contains no trained support vectors
23391	Kernel is not an RBF kernel
23392	Train data does not contain all classes
23393	SVM not trained
23394	Classifier not trained
23395	Serialized item does not contain a valid support vector machine (SVM)
23401	Wrong rotation number
23402	Wrong letter for Golay element
23403	Wrong reference point
23404	Wrong number of iterations
23405	Mophology: system error
23406	Wrong type of boundary
23407	Morphology: wrong number of input objects
23408	Morphology: wrong number of output objects
23409	Morphology: wrong number of input control parameter
23410	Morphology: wrong number of output control parameter
23411	Morphology: structuring element is infinite
23412	Morphology: wrong name for structuring element
23500	Wrong number of run length rows (chords): smaller than 0
23501	Number of chords too big. Increase 'current_runlength_number' using set_system!
23502	Run length row with negative length

23503	Run length row \geq image height
23504	Run length row < 0
23505	Run length column \geq image width
23506	Run length column < 0
23507	For CHORD_TYPE: Number of row too big
23508	For CHORD_TYPE: Number of row too small
23509	For CHORD_TYPE: Number of column too big
23510	Exceeding the maximum number of run lengths while automatical expansion
23511	Internal error: Region->compl neither TRUE/FALSE
23512	Internal error: Region->max_num $<$ Region->num
23513	Internal error: number of chords too big for num_max
23514	Operator cannot be implemented for complemented “
23520	Image width < 0
23521	Image width $> MAX_FORMAT$
23522	Image height < 0
23523	Image height $> MAX_FORMAT$
23524	Image width ≤ 0
23525	Image height ≤ 0
23550	Too many segments
23551	'int8' images are available on 64 bit systems only
23600	Point at infinity cannot be converted to a Euclidean point
23601	Covariance matrix could not be determined
23602	RANSAC algorithm didn't find enough point correspondences
23603	RANSAC algorithm didn't find enough point correspondences
23604	Internal diagnosis: fallback method had to be used
23605	Projective transformation is singular
23606	Mosaic is under-determined
23607	Input covariance matrix is not positive definite
23620	Inconsistent number of point correspondences
23621	At least one image cannot be reached from the reference image
23622	The image with specified index does not exist
23623	Matrix is not a camera matrix
23624	Skew is not zero
23625	Illegal focal length
23626	Distortion is not zero
23627	It is not possible to determine all parameters for variable camera parameters
23628	No valid implementation selected
23629	Kappa can only be determined with the gold-standard method
23630	Conflicting number of images and projection mode
23631	Error in projection: Point not in any cube map
23632	No solution found
23640	Illegal combination of estimation method and parameters to be determined
23650	Invalid file format for FFT optimization data
23651	The version of the FFT optimization data is not supported
23652	Optimization data was created with a different HALCON variant (Sequential HALCON / Parallel HALCON)
23653	Storing of the optimization data failed
23654	Serialized item does not contain valid FFT optimization data
23660	No contours suitable for self-calibration found
23661	No stable solution found: please change the inlier threshold or select contours manually
23662	Instable solution: please choose more or different contours
23663	Not enough contours for calibration: please select contours manually

23700	Epipoles are within the image domain: no rectification possible.
23701	Fields of view of both cameras do not intersect each other.
23750	Invalid sheet-of-light handle
23751	No sheet-of-light model available
23752	Wrong input image size (width)
23753	Wrong input image size (height)
23754	The bounding-box around the profile region does not fit the domain of definition of the input image
23755	Calibration extend not set
23756	Undefined disparity image
23757	Undefined domain for disparity image
23758	Undefined camera parameter
23759	Undefined pose of the lightplane
23760	Undefined pose of the camera coordinate system
23761	Undefined transformation from the coordinate system of the camera to the coordinate system of the lightplane
23762	Undefined movement pose for xyz calibration
23763	Wrong value of scale parameter
23764	Wrong parameter name
23765	Wrong type of parameter method
23766	Wrong type of parameter ambiguity
23767	Wrong type of parameter score
23768	Wrong type of parameter calibration
23769	Wrong type of parameter number_profiles
23770	Wrong type of element in parameter camera_parameter
23771	Wrong type of element in pose
23772	Wrong value of parameter method
23773	Wrong type of parameter min_gray
23774	Wrong value of parameter ambiguity
23775	Wrong value of parameter score_type
23776	Wrong value of parameter calibration
23777	Wrong value of parameter number_profiles
23778	Wrong type of camera
23780	Wrong number of values of pose
23850	The light source positions are linearly dependent
23851	No sufficient image indication
23852	Internal error: Function has equal signs in HZBrent
23900	Kalman: Dimension n,m or p has got a undefined value
23901	Kalman: File does not exist
23902	Kalman: Error in file (row of dimension)
23903	Kalman: Error in file (row of marking)
23904	Kalman: Error in file (value is no float)
23905	Kalman: Matrix A is missing in file
23906	Kalman: Matrix C is missing in file
23907	Kalman: Matrix Q is missing in file
23908	Kalman: Matrix R is missing in file
23909	Kalman: G or u is missing in file
23910	Kalman: Covariant matrix is not symmetric
23911	Kalman: Equation system is singular
24050	Image data management: object is a object tuple
24051	Image data management: object has been deleted already
24052	Image data management: wrong object-ID

24053	Image data management: object tuple has been deleted already
24054	Image data management: wrong object tuple-ID
24055	Image data management: object tuple is a object
24056	Image data management: object-ID is NULL (0)
24057	Image data management: object-ID outside the valid range
24058	Image data management: access to deleted image
24059	Image data management: access to image with wrong key
24060	Image data management: access to deleted region
24061	Image data management: access to region with wrong key
24062	Image data management: wrong value for image channel
24063	Image data management: index too big
24064	Image data management: index not defined
24100	No OpenCL available
24101	OpenCL Error occured
24102	No compute device available
24104	Out of compute device memory
24105	Invalid work group shape
24106	Invalid compute device
25100	Wrong (logical) window number
25101	Error while opening the window
25102	Wrong window coordinates
25103	It is not possible to open another window
25104	Device resp. operator not available
25105	Unknown color
25106	No window has been opened for desired action
25107	Wrong filling mode for regions (fill or margin)
25108	Wrong gray value (0..255)
25109	Wrong pixel value (use value of get_pixel(P) only)
25110	Wrong line width (see: query_line_width(Min,Max))
25111	Wrong name of cursor
25112	Wrong color table (see: query_lut(Name))
25113	Wrong representation mode (see: query_insert(Mode))
25114	Wrong representation color (see: query_color(List))
25115	Wrong dither matrix (binary image representation)
25116	Wrong image transformation (name or image size)
25117	Unsuitable image type for image transformation
25118	Wrong zooming factor for image transformation
25119	Wrong representation mode
25120	Wrong code of device
25121	Wrong number for father window
25122	Wrong window size
25123	Wrong window type
25124	No current window has been set
25125	Wrong color combination or range (RGB)
25126	Wrong number of pixels set
25127	Wrong value for comprise (object or image)
25128	set_fix with 1/4 image levels and static not valid
25129	set_lut not valid in child windows
25130	Number of concurrent used color tables is too big
25131	Wrong device for window dump
25132	Wrong window size for window dump
25133	System variable DISPLAY (setenv) not defined

25134	Wrong thickness for window margin
25135	System variable DISPLAY has been set wrong (<host>:0.0)
25136	Too many fonts loaded
25137	Wrong font name
25138	No valid cursor position
25139	Window is not a textual window
25140	Window is not a image window
25141	String too long or too high
25142	Too little space in the window rightwards
25143	Window is not suitable for the mouse
25144	Here Windows on a equal machine is permitted only
25145	Wrong mode while opening a window
25146	Wrong window mode for operation
25147	Operation not possible with fixed pixel
25148	Color tables for 8 image levels only
25149	Wrong mode for pseudo real colors
25150	Wrong pixel value for LUT
25151	Wrong image size for pseudo real colors
25152	Error in procedure HRLUT
25153	Wrong number of entries in color table for set_lut
25154	Wrong values for image area
25155	Wrong line pattern
25156	Wrong number of parameters for line pattern
25157	Wrong number of colors
25158	Wrong value for mode of area creation (0,1,2)
25159	Spy window is not set (set_spy)
25160	No file for spy has been set (set_spy)
25161	Wrong parameter output depth (set_spy)
25162	Wrong window size for window dump
25163	Wrong color table: wrong file name or query_lut()
25164	Wrong color table: empty string ?
25165	Using this hardware set_lut('default') is allowed only
25166	Error while calling online help
25167	Row can not be projected
25168	Operation is unsuitable using a computer with fixed color table
25169	Computer represents gray scales only (no colors)
25170	LUT of this display is full
25171	Internal error: wrong color code
25172	Wrong type for window attribute
25173	Wrong name for window attribute
25174	Negative height of area (or 0)
25175	Negative width of area (or 0)
25176	Window not completely visible
25177	Font not allowed for this operation
25178	Operation not possible (window was created in different thread)
25179	Depth was not stored with window
25180	Internal error: only RGB-Mode
25181	No more (image-)windows available
25182	Object index was not stored with window
25183	Operator does not support primitives without point coordinates
25184	Operator not available with Windows Remote Desktop
25185	No OpenGL support available

25186	No depth information available
25187	OpenGL error occurred
25188	Required framebuffer object is unsupported
25189	OpenGL accelerated hidden surface removal not supported on this machine
25190	Invalid window parameter
25191	Invalid value for window parameter
25192	Unknown mode
25195	Invalid value for navigation mode
25196	Internal file error
25197	Error while file synchronization
25198	Insufficient rights on file
25199	Bad file descriptor
25200	File not found
25201	Error while writing image data (sufficient memory ?)
25202	Error while writing image descriptor (sufficient memory ?)
25203	Error while reading image data (format of image too small ?)
25204	Error while reading image data (format of image too big ?)
25205	Error while reading image descriptor: file too small
25206	Image matrices are different
25207	Help file not found (setenv HALCONROOT <Halcon- Homedirectory>)
25208	Help index not found (setenv HALCONROOT <Halcon- Homedirectory>)
25209	File <standard_input> can not be closed
25210	<standard_output/error> can not be closed
25211	File can not be closed
25212	Error while writing to file
25213	Exceeding of maximum number of files
25214	Wrong file name
25215	Error while opening the file
25216	Wrong file mode
25217	Wrong type for pixel (e.g. byte)
25218	Wrong image width (too big ?)
25219	Wrong image height (too big ?)
25220	File already exhausted before reading an image
25221	File exhausted before terminating the image
25222	Wrong value for resolution (dpi)
25223	Wrong output image size (width)
25224	Wrong output image size (height)
25225	Wrong number of parameter values: format description
25226	Wrong parameter name for operator
25227	Wrong slot name for parameter
25228	Operator class is missing in help file
25229	Wrong or inconsistent help/* .idx or help/* .sta
25230	File help/* .idx not found (setenv HALCONROOT <Halcon- Homedirectory>)
25231	File help/* .sta not found (setenv HALCONROOT <Halcon- Homedirectory>)
25232	Inconsistent file help/* .sta
25233	No explication file (.exp) found
25234	No file found in known graphic format
25235	Wrong graphic format
25236	Inconsistent file halcon.num
25237	File not a TIFF file
25238	Wrong file format
25239	gnuplot could not be started

25240	Output file for gnuplot could not be opened
25241	Not a valid gnuplot output stream
25242	No PNM format
25243	Inconsistent or old help file (\$HALCONROOT/help)
25244	Wrong file handle
25245	File not open
25246	No files in use so far (none opened)
25247	Invalid file format for regions
25248	Error while reading region data: Format of region too big.
25250	Invalid handle for a serial connection
25251	Serial port not open
25252	No serial port available
25253	Could not open serial port
25254	Could not close serial port
25255	Could not get serial port attributes
25256	Could not set serial port attributes
25257	Wrong baud rate for serial connection
25258	Wrong number of data bits for serial connection
25259	Wrong flow control for serial connection
25260	Could not flush serial port
25261	Error during write to serial port
25262	Error during read from serial port
25270	Serialized item does not contain valid regions
25271	The version of the regions is not supported
25272	Serialized item does not contain valid images
25273	The version of the images is not supported
25274	Serialized item does not contain valid XLD objects
25275	The version of the XLD objects is not supported
25276	Serialized item does not contain valid objects
25277	The version of the objects is not supported
25280	File has not been opened in text format
25281	File has not been opened in binary file format
25282	Cannot create directory
25283	Cannot remove directory
25300	No image acquisition device opened
25301	Image acquisition: wrong color depth
25302	Image acquisition: wrong device
25303	Image acquisition: determination of video format not possible
25304	Image acquisition: no video signal
25305	Unknown image acquisition device
25306	Image acquisition: failed grabbing of an image
25307	Image acquisition: wrong resolution chosen
25308	Image acquisition: wrong image part chosen
25309	Image acquisition: wrong pixel ratio chosen
25310	Image acquisition: handle not valid
25311	Image acquisition: instance not valid (already closed?)
25312	Image acquisition: device cannot be initialized
25313	Image acquisition: external triggering not supported
25314	Image acquisition: wrong camera input line (multiplex)
25315	Image acquisition: wrong color space
25316	Image acquisition: wrong port
25317	Image acquisition: wrong camera type

25318	Image acquisition: maximum number of acquisition device classes exceeded
25319	Image acquisition: device busy
25320	Image acquisition: asynchronous grab not supported
25321	Image acquisition: unsupported parameter
25322	Image acquisition: timeout
25323	Image acquisition: invalid gain
25324	Image acquisition: invalid field
25325	Image acquisition: invalid parameter type
25326	Image acquisition: invalid parameter value
25327	Image acquisition: function not supported
25328	Image acquisition: incompatible interface version
25329	Image acquisition: could not set parameter value
25330	Image acquisition: could not query parameter setting
25331	Image acquisition: parameter not available in current configuration
25332	Image acquisition: device could not be closed properly
25333	Image acquisition: camera configuration file could not be opened
25334	Image acquisition: callback type not supported
25335	Image acquisition: device lost
25400	Image type is not supported
25401	Invalid pixel format
25402	Internal JPEG-XR error
25403	Invalid format string
25404	Maximum number of channels exceeded
25405	Unspecified error in JPEG-XR library
25406	Bad magic number in JPEG-XR library
25407	Feature not implemented in JPEG-XR library
25408	File read/write error in JPEG-XR library
25409	Invalid file format in JPEG-XR library
25500	Error while closing the image file
25501	Error while opening the image file
25502	Premature end of the image file
25503	Image dimensions too large for this file format
25504	Image too large for this HALCON version
25505	Too many iconic objects for this file format
25510	File is no PCX-File
25511	PCX: unknown encoding
25512	PCX: More than 4 image plains
25513	PCX: Wrong magic in color table
25514	PCX: Wrong number of bytes in span
25515	PCX: Wrong number of bits/pixels
25516	PCX: Wrong number of plains
25520	File is no GIF-File
25521	GIF: Wrong version (not 87a/89a)
25522	GIF: Wrong descriptor
25523	GIF: Wrong color table
25524	GIF: Premature end of file
25525	GIF: Wrong number of images ','
25526	GIF: Wrong image extension '!'
25527	GIF: Wrong left top width
25528	GIF: Cyclic index of table
25529	GIF: Wrong image data
25530	File is no Sun-Raster-File

25531	SUN-Raster: Wrong header
25532	SUN-Raster: Wrong image width
25533	SUN-Raster: Wrong image height
25534	SUN-Raster: Wrong color map
25535	SUN-Raster: Wrong image data
25536	SUN-Raster: Wrong type of pixel
25540	XWD: Wrong type of pixel
25541	XWD: Wrong visual class
25542	XWD: Wrong X10 header
25543	XWD: Wrong X11 header
25544	XWD: Wrong X10 colormap
25545	XWD: Wrong X11 colormap
25546	XWD: Wrong pixmap
25547	XWD: unknown version
25548	XWD: Error while reading an image
25550	TIFF: Error while reading a file
25551	TIFF: Wrong colormap
25552	TIFF: Too many colors
25553	TIFF: Wrong photometric interpretation
25554	TIFF: Wrong photometric depth
25555	TIFF: Image is no binary file
25556	TIFF: Image format not supported by HALCON
25557	TIFF: Wrong specification of the TIFF file format
25558	TIFF: TIFF file is corrupt
25559	TIFF: A required TIFF tag is missing in the TIFF file
25560	File is no BMP-File
25561	BMP: Premature end of file
25562	BMP: Incomplete header
25563	BMP: Unknown bitmap format
25564	BMP: Unknown compression format
25565	BMP: Wrong color table
25566	BMP: Write error on output
25567	BMP: File does not contain a binary image
25570	JPEG: wrong number of components in image
25571	JPEG: unknown error from libjpeg
25572	JPEG: no implemented feature in libjpeg
25573	JPEG: file access error in libjpeg
25574	JPEG: tmp file access error in libjpeg
25575	JPEG: memory error in libjpeg
25576	JPEG: Error in input image
25580	PNG: File is not a PNG file
25581	PNG: Unknown interlace type
25582	PNG: Unsupported color type
25583	PNG: Image is no binary file
25590	JPEG-2000: File corrupt
25591	JPEG-2000: Image has more than 28 significant bits
25592	JPEG-2000: Error while encoding
25600	Socket can not be set to block
25601	Socket can not be set to unblock
25602	Received data is no tuple
25603	Received data is no image
25604	Received data is no region

25605	Received data is no xld object
25606	Error while reading from socket
25607	Error while writing to socket
25608	Illegal number of bytes with get_rl
25609	Buffer overflow in read_data
25610	Socket can not be created
25611	Bind on socket failed
25612	Socket information is not available
25613	Socket cannot listen for incoming connections
25614	Connection could not be accepted
25615	Connection request failed
25616	Hostname could not be resolved
25617	No data on socket
25618	Unknown tuple type on socket
25619	Timeout occurred on socket
25620	No more sockets available
25621	Socket is not initialized
25622	Invalid socket
25623	Socket is NULL
25624	Received data type is too large
25625	Wrong socket protocol
25626	Received data does not contain packed data
25627	Error when handling the parameter
25628	Format specification does not match the data
25629	Invalid format specification
25630	Received data is no serialized item
25678	XLD object data can only be read by HALCON XL
25700	Too many contours/polygons for this file format
25750	The version of the quaternion is not supported
25751	Serialized item does not contain a valid quaternion
25752	The version of the homogeneous matrix is not supported
25753	Serialized item does not contain a valid homogeneous matrix
25754	The version of the homogeneous 3D matrix is not supported
25755	Serialized item does not contain a valid homogeneous 3D matrix
25756	The version of the tuple is not supported
25757	Serialized item does not contain a valid tuple
25758	Tuple data can only be read on 64-bit systems
25759	The version of the camera parameters (pose) is not supported
25760	Serialized item does not contain valid camera parameters (pose)
25761	The version of the internal camera parameters is not supported
25762	Serialized item does not contain valid internal camera parameters
26000	Access to undefined memory area
26001	Not enough memory available
26002	Memory partition on heap has been overwritten
26003	HALloc: 0 bytes requested
26004	Tmp-memory management: Call freeing memory although nothing had been allocated
26005	Tmp-memory management: Null pointer while freeing
26006	Tmp-memory management: could not find memory element
26007	Memory management: wrong memory type allocated
26021	Not enough video memory available
26040	System parameter for memory-allocation inconsistent
26041	No memory block allocated at last

26500	Process creation failed
27000	Wrong index for output control parameter
27001	Wrong number of values: output control parameter (see: HPut*Par)
27002	Wrong type: output control parameter (see: HPut*Par)
27003	Wrong data type for object key (input objects)
27004	Range for integer had been passed
27005	Inconsistent Halcon version
27006	Not enough memory for strings allocated
27007	Internal error: Proc is NULL
27100	Wrong list structure using input objects
27101	Wrong input object parameter (not bound)
27102	Wrong input control parameter (not bound)
27103	Wrong output object parameter (already bound)
27104	Wrong output control parameter (already bound)
27105	Unknown symbolic object key (input objects)
27200	Wrong number of output object parameter
27300	Wrong number of input parameter
27400	System error: output type <string> expected
27401	System error: output type <long> expected
27402	System error: output type <float> expected
27403	Object parameter is a zero pointer ('_' not allowed)
27404	Tupel had been deleted; values are not valid any more
27430	C++-interface internal error: wrong object mode
27431	Wrong number of regions (> 1) for type HRegion
27432	Wrong number of images (> 1) for type HImage
27433	Tupel with undefined values
27500	No contact to RPC server
27501	Error in remote procedure call
27600	Parameter value is neither a list nor a atom
28000	Unknown operator name
28001	register_comp_used is not activated (see set_system)
28002	Unknown operator class
28101	convol/mask: error while opening the file
28102	convol/mask: premature end of file
28103	convol/mask: conversion error
28104	convol/mask: wrong row-/column number
28105	convol/mask: mask size overflow
28106	convol/mask: too many elements entered
28107	convol: wrong margin type
28108	convol: no mask object has got empty region
28110	convol: Weight factor is 0
28111	convol: inconsistent number of weights
28112	rank: wrong rank value
28113	convol/rank: error while handling margin
28114	Error while parsing filter mask file
28120	Wrong number of coefficients for convolution (sigma too big?)
28200	No valid ID for data set
28201	No data set active (set_bg_esti)
28202	ID already used for data set (is not possible)
28204	No data set created (create_bg_esti)
28205	Not possible to pass an object list
28206	Image has other size than the background image in data set

28207	Up-date-region is bigger than background image
28208	Number of statistic data sets is too small
28209	Wrong value for adapt mode
28210	Wrong value for frame mode
28300	Maximum number of fonts exceeded
28301	Wrong ID (Number) for font
28302	OCR internal error: wrong ID
28303	OCR not initialised: no font was read in
28304	No font activated
28305	OCR internal error: wrong threshold in angle determination
28306	OCR internal error: wrong attribute
28307	The version of the OCR classifier is not supported
28308	OCR File: inconsistent number of nodes
28309	OCR File: File too short
28310	OCR: internal error 1
28311	OCR: internal error 2
28312	Wrong type of OCR tool (no 'box' or 'net')
28313	The version of the OCR training characters is not supported
28314	Image too large for training file
28315	Region too large for training file
28316	Protected training file
28317	Wrong password for protected training file
28318	Serialized item does not contain a valid OCR classifier
28320	Invalid file format for MLP classifier
28321	The version of the MLP classifier is not supported
28322	Serialized item does not contain a valid MLP classifier
28330	Invalid file format for SVM classifier
28331	The version of the SVM classifier is not supported
28332	Serialized item does not contain a valid k-NN classifier
28333	Invalid file format for k-NN classifier
28340	Invalid text model
28341	Invalid text result
28350	OCV system not initialized
28351	The version of the OCV tool is not supported
28353	Wrong name for an OCV object
28354	Training has already been applied
28355	No training has been applied to the character
28356	Serialized item does not contain a valid OCV tool
28370	Wrong number of function points
28371	List of values is not a function
28372	Wrong ordering of values (not ascending)
28373	Illegal distance of function points
28374	Function is not monotonic
28375	Wrong function type
28400	You have to indicate at least 3 calibration points
28402	No calibration table found
28403	Error while reading calibration table description file
28404	Minimum threshold while searching for ellipses
28405	Read error / format error in calibration table description file
28406	Error in projection: $s_x = 0$ or $s_y = 0$ or $z = 0$
28407	Error in inverse projection
28408	Not possible to open camera parameter file

28409	Format error in file: no colon
28410	Format error in file: 2. colon is missing
28411	Format error in file: semicolon is missing
28412	Not possible to open camera parameter (pose) file
28413	Format error in camera parameter (pose) file
28414	Not possible to open calibration target description file
28415	Not possible to open postscript file of calibration target
28416	Error while norming the vector
28417	Fitting of calibration target failed
28418	No next mark found
28419	Normal equation system is not solvable
28420	Average quadratic error is too big for 3D position of mark
28421	Non elliptic contour
28422	Wrong parameter value slvand()
28423	Wrong function results slvand()
28424	Distance of marks in calibration target description file is not possible
28425	Specified flag for degree of freedom not valid
28426	Minimum error did not fall below
28427	Wrong type in Pose (rotation / translation)
28428	Image size does not match the measurement in camera parameters
28429	Point could not be projected into linescan image
28430	Diameter of calibration marks could not be determined
28431	Orientation of calibration plate could not be determined
28432	Calibration plate does not lie completely inside the image
28433	Wrong number of calibration marks extracted
28434	Unknown name of parameter group
28435	Focal length must be non-negative
28436	Function not available for cameras with telecentric lenses
28437	Function not available for line scan cameras
28438	Ellipse is degenerated to a point
28439	No orientation mark found
28440	Camera calibration did not converge
28441	Error in calibration data, try to recalibrate with improved input data!
28442	Point cannot be distorted
28451	Model not optimized yet -0 no results can be queried
28452	Model not postprocessed yet -0 no auxiliary results can be queried
28453	Calibration setup: fields of view do not intersect
28454	Camera type and camera parameters incompatible
28455	Calibration setup: incompatible camera types
28456	Camera type not supported
28457	Invalid camera index
28458	Invalid calibration object index
28459	Invalid calibration object pose index
28460	Undefined camera
28461	Indices: ambiguous observation index
28462	Undefined calibration object
28463	Invalid file format for calibration data model
28464	The version of the calibration data model is not supported
28465	Zero-motion in line scan camera parameters
28466	Calibration setup: multiple cameras and/or calibration objects not supported for camera type
28467	Incomplete observation data

28468	Invalid file format for camera setup model
28469	The version of the camera setup model is not supported
28470	Full HALCON calibration plate description required
28471	Invalid observation index
28472	Serialized item does not contain a valid camera setup model
28473	Serialized item does not contain a valid calibration data model
28474	Invalid tool pose index
28475	Undefined tool pose
28476	Feature or operation not supported for current calibration data model type
28490	Feature or operation not supported for current stereo model type
28491	Feature or operation available only in 'persistent' mode
28492	Invalid bounding box
28493	Image sizes must be identical with the corresponding camera parameters from the camera setup
28494	Bounding box lies partially or completely behind the base line of at least one camera pair
28495	Ambiguous calibration: Please, recalibrate with improved input data!
28496	Pose of calibration plate could not be determined!
28500	Invalid file format for template
28501	The version of the template is not supported
28502	Error during changing the file mode (t/b)
28503	Inconsistent match file: coordinates out of range
28505	The image(s) is not a pyramid (wrong zooming factor?)
28506	Number of template points too small
28507	Template data can only be read by HALCON XL
28508	Serialized item does not contain a valid NCC model
28509	Serialized item does not contain a valid template
28510	Number of shape model points too small
28511	Gray-value-based and color-based shape models cannot be searched simultaneously
28512	Shape model data can only be read by HALCON XL
28513	Shape model was not created from XLDs
28514	Serialized item does not contain a valid shape model
28530	Initial components have different region types
28531	Solution of ambiguous matches failed
28532	Computation of the incomplete gamma function not converged
28533	Too many nodes while computing the minimum spanning arborescence
28534	Component training data can only be read by HALCON XL
28535	Component model data can only be read by HALCON XL
28536	Serialized item does not contain a valid component model
28537	Serialized item does not contain a valid component training result
28540	Size of the training image and the variation model differ
28541	Variation model has not been prepared for segmentation
28542	Invalid variation model training mode
28543	Invalid file format for variation model
28544	The version of the variation model is not supported
28545	Training data has already been cleared
28546	Serialized item does not contain a valid variation model
28550	No more measure objects available
28551	Measure object is not initialized
28552	Invalid measure object
28553	Measure object is NULL
28554	Measure object has wrong image size
28555	Invalid file format for measure object

28556	The version of the measure object is not supported
28557	Measure object data can only be read by HALCON XL
28558	Serialized item does not contain a valid measure object
28570	Metrology model is not initialized
28571	Invalid metrology model
28572	Invalid metrology object
28573	Not enough valid measures for fitting the metrology object
28575	Invalid file format for metrology model
28576	The version of the metrology model is not supported
28577	Fuzzy function is not set
28578	Serialized item does not contain a valid metrology model
28600	Dynamic library could not be opened
28601	Dynamic library could not be closed
28602	Symbol not found in dynamic library
28650	Not enough information for radiometric calibration
28700	Unknown barcode
28701	Wrong number of modules
28702	Wrong number of elements
28703	Unknown character (for this code)
28705	wrong name for attribute in barcode descriptor
28706	Wrong thickness of element
28707	No region found
28708	Wrong type of barcode
28720	Invalid barcode handle
28721	List of barcode models is empty
28722	Training cannot be done for multiple barcode types
28723	Cannot get barcode type specific parameter with <code>get_bar_code_param</code> . Use <code>get_bar_code_param_specific</code>
28724	Cannot get this object for multiple barcode types. Try again with single barcode type
28725	Invalid file format for barcode model
28726	The version of the barcode model is not supported
28800	Specified code type is not supported
28801	Wrong foreground specified
28802	Wrong matrix size specified
28803	Wrong symbol shape specified
28804	Wrong generic parameter name
28805	Wrong generic parameter value
28806	Wrong symbol printing mode
28807	Symbol region too near to image border
28808	No rectangular module boundings found
28809	Couldn't identify symbol finder
28810	Symbol region with wrong dimension
28811	Classification failed
28812	Decoding failed
28813	Reader programming not supported
28820	General 2d data code error
28821	Corrupt signature of 2d data code handle
28822	Invalid 2d data code handle
28823	List of 2d data code models is empty
28825	Invalid 'Candidate' parameter
28829	Unexpected 2d data code error
28830	Invalid parameter value
28831	Unknown parameter name

28832	Invalid value for 'polarity'
28833	Invalid value for 'symbol_shape'
28834	Invalid symbol size
28835	Invalid module size
28836	Invalid value for 'module_shape'
28837	Invalid value for 'orientation'
28838	Invalid value for 'contrast_min'
28839	Invalid value for 'measure_thresh'
28840	Invalid value for 'alt_measure_red'
28841	Invalid value for 'slant_max'
28842	Invalid value for 'L_dist_max'
28843	Invalid value for 'L_length_min'
28844	Invalid module gap
28845	Invalid value for 'default_parameters'
28846	Invalid value for 'back_texture'
28847	Invalid value for 'mirrored'
28848	Invalid value for 'classifier'
28849	Invalid value for 'persistence'
28850	Invalid model type
28851	Invalid value for 'module_roi_part'
28852	Invalid value for 'finder_pattern_tolerance'
28853	Invalid value for 'mod_aspect_max'
28854	Invalid value for 'small_modules_robustness'
28863	Invalid module aspect ratio
28864	Invalid layer num
28865	Wrong data code model file version
28866	Serialized item does not contain a valid 2D data code model
28900	Unknown parameter name
28901	Invalid value for 'num_levels'
28902	Invalid value for 'optimization'
28903	Invalid value for 'metric'
28904	Invalid value for 'min_face_angle'
28905	Invalid value for 'min_size'
28910	The projected model is too large “
28920	Invalid value for 'longitude_min'
28921	Invalid value for 'longitude_max'
28922	Invalid value for 'latitude_min'
28923	Invalid value for 'latitude_max'
28924	Invalid value for 'cam_roll_min'
28925	Invalid value for 'cam_roll_max'
28926	Invalid value for 'dist_min'
28927	Invalid value for 'dist_max'
28928	Invalid value for 'num_matches'
28929	Invalid value for 'max_overlap'
28933	Invalid value for 'border_model'
28940	Pose is not well-defined
28941	Invalid file format for 3D shape model
28960	Invalid file format for descriptor model
28961	The version of the descriptor model is not supported
28962	Invalid value for 'radius'
28963	Invalid value for 'check_neighbor'
28964	Invalid value for 'min_check_neighbor_diff'
28965	Invalid value for 'min_score'

28966	Invalid value for 'sigma_grad'
28967	Invalid value for 'sigma_smooth'
28968	Invalid value for 'alpha'
28969	Invalid value for 'threshold'
28970	Invalid value for 'depth'
28971	Invalid value for 'number_trees'
28972	Invalid value for 'min_score_descr'
28973	Invalid value for 'patch_size'
28974	Invalid value for 'tilt'
28975	Invalid value for 'guided_matching'
28976	Invalid value for 'subpix'
28977	Too few feature points can be found
28978	Invalid value for 'min_rot'
28979	Invalid value for 'max_rot'
28980	Invalid value for 'min_scale'
28981	Invalid value for 'max_scale'
28982	Invalid value for 'mask_size_grd'
28983	Invalid value for 'mask_size_smooth'
28984	Model broken
28985	Invalid value for 'descriptor_type'
28986	Invalid value for 'matcher'
28987	Too many point classes -0 model storing in a file is not possible
28988	Serialized item does not contain a valid descriptor model
29000	Function not implemented on this machine
29001	Image to process has wrong gray value type
29002	Wrong image component (see: get_system(obj_images,H))
29003	Undefined gray values
29004	Wrong image format for operation (too big or too small)
29005	Wrong number of image components for image output
29006	String is too long (max. 1024 characters)
29007	Wrong pixel type for this operation
29008	Operation not realized yet for this pixel type
29009	Image is no color image with three channels
29010	Image acquisition devices are not supported in the demo version
29011	Packages are not supported in the demo version
29020	Internal error: Unknown value
29021	Image domain too small.
29022	Input dimension too small
29023	Draw operator has been canceled
29050	Operator is not available in this restricted version of HALCON
29051	Packages are not available in this restricted version of HALCON
29052	The selected image acquisition interface is not available in this restricted version of HALCON
29100	Too many unknown variables in linear equation
29101	No (unique) solution for the linear equation
29102	Too little equations in linear equation
29200	Matrix is not invertible
29201	Singular value decomposition did not converge
29202	Matrix has too few rows for singular value partition
29203	Eigenvalue computation did not converge
29204	Eigenvalue computation did not converge
29205	Matrix is singular

29206 Function matching did not converge
29207 Input matrix undefined
29208 Input matrix with wrong dimension
29209 Input matrix is not quadratic
29210 Matrix operation failed
29211 Matrix is not positive definite
29212 One element of the matrix is zero: Division by zero
29213 Matrix is not an upper triangular matrix
29214 Matrix is not a lower triangular matrix
29215 One element of the matrix is negative
29216 Matrix file: Invalid character
29217 Matrix file: Matrix incomplete
29218 Invalid file format for matrix
29219 Resulting matrix has complex values
29220 Wrong value in matrix of exponents
29221 The version of the matrix is not supported
29222 Serialized item does not contain a valid matrix
29230 Internal error: wrong Node
29231 Inconsistent red black tree
29250 Internal error: Wrong LAPACK parameter
29260 Number of points too small for spherical triangulation
29261 First three points are collinear in spherical triangulation
29262 Spherical triangulation contains identical input points
29263 Internal error: array not allocated large enough for spherical triangulation
29264 Spherical Voronoi diagram contains degenerate triangle
29265 Internal error: inconsistent spherical triangulation
29266 Spherical Voronoi diagram contains self-intersecting polygon
29267 Internal error: inconsistent spherical polygon data
29268 Internal error: Ambiguous great circle arc intersection
29269 Internal error: Ambiguous great circle arc
29270 Internal error: Illegal parameter
29280 Not enough points for planar triangular meshing
29281 The first three points of the triangular meshing are collinear
29282 Planar triangular meshing contains identical input points
29283 Invalid points for planar triangular meshing
29284 Internal error: allocated array too small for planar triangular meshing
29285 Internal error: planar triangular meshing inconsistent
29300 Eye point and reference point coincide
29400 Timeout occurred
29401 Invalid value for timeout
29450 Invalid value for 'sub_object_size'
29451 Invalid value for 'min_size'
29452 Invalid number of least-squares iterations
29453 Invalid value for 'angle_step'
29454 Invalid value for 'scale_r_step'
29455 Invalid value for 'scale_c_step'
29456 Invalid value for 'max_angle_distortion'
29457 Invalid value for 'max_aniso_scale_distortion'
29458 Invalid value for 'min_size'
29459 Invalid value for 'cov_pose_mode'
29460 Model contains no calibration information
29461 Generic parameter name does not exist

29462	Provided camera parameters have different resolution than image
29463	Invalid file format for deformable model
29464	The version of the deformable model is not supported
29465	Invalid 'deformation_smoothness'
29466	Invalid 'expand_border'
29467	Model origin outside of axis-aligned bounding rectangle of template region
29468	Serialized item does not contain a valid deformable model
29500	3D Object Model has no points
29501	3D Object Model has no faces
29502	3D Object Model has no normals
29506	Invalid file format for 3D surface model
29507	The version of the 3D surface model is not supported
29508	Serialized item does not contain a valid 3D surface model
29510	Invalid 3D file
29511	Invalid 3D object model
29512	Unknown file type
29513	The version of the 3D object model is not supported
29514	Required attribute missing in 3D object model
29515	Required points missing in 3D object model
29516	Required normals missing in 3D object model
29517	Required triangulation missing in 3D object model
29518	Required polylines missing in 3D object model
29519	Required triangle neighborhood missing in 3D object model
29520	Required polygons missing in 3D object model
29521	Required 2D mapping missing in 3D object model
29522	Required primitive missing in 3D object model
29523	Required 3D shape model missing in 3D object model
29524	Required extended attribute missing in 3D object model
29525	Serialized item does not contain a valid 3D object model
29526	Primitive in 3D object model has no extended data
29527	Operation invalid, 3D object model already contains triangles
29528	Operation invalid, 3D object model already contains lines
29529	Operation invalid, 3D object model already contains faces or polygons
29530	For at least one input 3D object model no neighbor with sufficient surface overlap is available.
29531	All components of points must be set at once
29532	All components of normals must be set at once
29533	Number of values doesn't correspond to number of already existing points
29534	Number of values doesn't correspond to number of already existing normals
29535	Number of values doesn't correspond to already existing triangulation
29536	Number of values doesn't correspond to length of already existing polygons
29537	Number of values doesn't correspond to length of already existing polylines
29538	Number of values doesn't correspond to already existing 2D mapping
29539	Number of values doesn't correspond to already existing extended attribute
29550	Triangles of the 3D object model are not suitable for this operator
29551	Too few suitable 3D points in the 3D object model
29580	Invalid file format for serialized items
29581	Serialized item: premature end of file
29600	Invalid value for 'image_resize_method'
29601	Invalid value for 'image_resize_value'
29602	Invalid value for 'rating_method'
29603	At least one type of image information must be added

29604	Sample identifier does not contain color information
29605	Sample identifier does not contain texture information
29606	Sample image does not contain enough information
29607	Sample identifier does not contain unprepared data (use add_sample_identifier_preparation_data)
29608	Sample identifier has not been prepared yet (use prepare_sample_identifier)
29609	Sample identifier does not contain untrained data (use add_sample_identifier_training_data)
29610	Sample identifier has not been trained yet (use train_sample_identifier)
29611	Sample identifier does not contain result data
29612	Sample identifier must contain at least two training objects (use add_sample_identifier_training_data)
30000	no error
30001	Input invalid
30002	Input negative
30003	Input exceeded range
30004	Memory exceeded boundary
30004	Memory allocation failure
30006	Memory pointer null
30007	DMA failure
30008	File open failure
30009	File read failure
30010	File write failure
30011	File close failure
30012	File format failure
30013	Warning low memory
40000	No error occurred in camera device.
40001	Initialization of image chip driver failed.
40002	Converting image to RGB or HSV failed.
40003	The capture process timed out.
40004	Arming video driver failed -> driver is in error state.
40005	Setting up image chip failed while changing size.
40006	Setting up video driver failed while changing size.
40007	Setting up image chip failed while changing brightness.
40008	Setting light mode failed -> typically UART communication.
40009	Setting focus pos. failed -> typically UART communication.
40010	Auto focus process failed -> typically UART communication.
50001	Indicates the configuration is invalid.
50002	Indicates the configuration API was not initialized.
50003	Indicates the configuration API was already initialized.
50004	Indicates that a function argument was invalid.
50005	Indicates a channel was defined twice.
50006	One has tried to define more than 2 quadrature channels.
50007	Indicates that more than 1 TRIGGER inputs is defined.
50008	Indicates that more than 1 READY signal is defined.
50009	Indicates that more than 1 FLASH output is defined.
50010	Indicates that more than 1 PROCESS output is defined.
50011	Indicates that more than 1 CAPTURE output is defined.
50012	Indicates that more than 1 PROJECT_SELECT feedback output defined.
50013	Indicates that more than 1 PROJECT_SELECT input is defined.
50014	Indicates invalid configuration of timer/quadrature.
50015	Indicates PRU couldn't started.

18.7. Changelog operating instructions

Version	Date	Description / changes	Respective software version
1.0.0	18.02.14	Initial version of operating instructions	Software: 1.0.X Firmware: 1.0.X
1.1.0	23.05.14	Features: <ul style="list-style-type: none"> • Introduction of project template files • Update of the training demo files • Enhancements of the Module Image Comparison visualization • Magic Wand for Module Threshold and Module Threshold HSV • Enhanced parameters for Module Code 1D/2D • Special character editor for e.g. Device Communication • Text edit supports scientific format • Optimization of the „Advanced Mode“ 	Software: 1.1.X Firmware: 1.1.X
1.2.0	23.02.15	Features: <ul style="list-style-type: none"> • Extended functionality of the coordinate system module • Enlarged localizer teach box • Introduction of new measuring methods for the measuring module • User management • New trigger functions / camera module • Trigger queue • Project change via digital I/O • Rename modules • Shortened read timeout for 1D and 2D codes • Introduction of online data monitoring • Industrial Ethernet as trigger input • Expanded data information in Teach+ files • Error handling 	Software: 1.2.0 Firmware: 1.2.0
1.3.0	17.11.15	Features: <ul style="list-style-type: none"> • Project Converter • new languages for the software • Modul OCR • Ethernet/IP • copy Moduls • move Modules 	Software: 1.2.0 Firmware: 1.2.0
1.3.1	04.03.16	Features: <ul style="list-style-type: none"> • Correcting typos 	Software: 1.3.x Firmware: 1.3.x
1.3.2	12.04.16	Features: <ul style="list-style-type: none"> • OCR-Tips 	Software: 1.3.x Firmware: 1.3.x
1.3.3	31.08.16	<ul style="list-style-type: none"> • Minor enhancements • Adaptation of the technical data 	Software: 1.3.x Firmware: 1.3.x
1.4.0	17.02.17	Features: <ul style="list-style-type: none"> • Module Pattern matching 	Software: 1.4.x Firmware: 1.4.x

1.4.2	24.04.17	Features: • DXF Editor Module Pattern matching	Software: 1.4.x Firmware: 1.4.x
1.4.5	14.08.18	Correct upgrade and downgrade options	Software 1.4.x Firmware 1.4.x

18.8. Software changelog

18.8.1. Firmware changelog

Version	Release date	Description / changes	Compatibility
1.2.2	12.06.15	Patch release Bug fixes: <ul style="list-style-type: none"> • Folder structure will be created on new SD Card at startup • Loading a configuration from another sensor does not delete existing license keys • Change Projects over display up to 50 projects • Device IO Unit: Module State set on error conditions • Module Statistics: Process time calculated correct • OLED Display: Clear warning symbol • Online Data Monitoring support for large projects • Profinet Sensors can be found • Trigger Input (Industrial Ethernet) link get lost on project load • Handle circular dependencies for images • Coordinate System: No error when points are linked • Device State message in DHCP mode • HW trigger works after use of magic wand • minor bugs 	Projects: 1.2.x PC Software: 1.2.x
1.3.0	17.11.15	Minor release Features: <ul style="list-style-type: none"> • Module OCR • Ethernet/IP • Support of weQube C-Mount Bug fixes: <ul style="list-style-type: none"> • no separator between preamble and postamble characters • Output queue can't get asynchron • Profinet trigger resets internal links • PROFINET project load only on project slot change • PROFINET initialize slots after a project change • Localizer on sensor and PC calculate the same result 	Projects: 1.3.0

Version	Release date	Description / changes	Compatibility
1.3.1	26.02.16	Bug fixes: <ul style="list-style-type: none"> • Licence check works for large projects • Double Min and Max values available after project load • PROFINET device connect to PLC after update form 1.2.x • Increase performance of Module Filter • OLED only accept a valid password • No crash after project changes • Double values linked to string are not truncated • ReduceTrigger Delay jitter • Minor Bugs 	Projects: 1.3.x
1.3.2	29.04.16	Bug fixes: <ul style="list-style-type: none"> • Error Handling works after Project reopen • Device IO Unit Output Hold Time in ms -PROFINET using webserver may not break the connection • PROFINET Trigger does not crash the sensor • OCR Multiline correct segmentation of 2nd line • FTP Transfer of string files stop after observing 	Projects: 1.3.x
1.3.3	03.04.18	Compatible with new flash memory Note! After updating the device to this version, downgrading to a lower firmware version is no longer possible (see section “8.3. Upgrade and Downgrade Options” on page 38).	Projekte 1.3.x
1.3.4	14.08.18	Bug fixes: <ul style="list-style-type: none"> • Loading projects and creating new projects Note! After updating the device to this version, downgrading to a lower firmware version is no longer possible (see section “8.3. Upgrade and Downgrade Options” on page 38).	Projects 1.3.x

Version	Release date	Description / changes	Compatibility
1.4.0	17.02.17	<p>Minor Release</p> <p>Functions:</p> <ul style="list-style-type: none"> • Rotation of the input image • White balancing (color version) • Toggle bit • Pattern matching • Industrial Ethernet, new data types • Measuring module, point usage • Logic module, several inputs • Math module, several inputs • Extended temperature range <p>Bug fixes:</p> <ul style="list-style-type: none"> • Read-out box with weQube C mount • Ethernet/IP byte order is not changed correctly after loading a project. • Changing over to the flash mode switches internal illumination off. • Memory leak during project loading eliminated • Profinet trigger causes processor to crash 	<p>Projects: 1.x.x</p> <p>Firmware: 1.4.x</p>
1.4.1	15.03.17	<p>Bug fixes:</p> <ul style="list-style-type: none"> • When a new Halcon license is added, existing Halcon licenses for the weQube are lost. 	<p>Projects: 1.4.x</p> <p>Firmware: 1.4.x</p>
1.4.2	03.05.17	<p>Bug fixes:</p> <ul style="list-style-type: none"> • Projectconverter • Input linking for Module Pattern Match doesn't work • Sensor reboot • Magic wand Module Threshold HSV blocks Software • Readtimeout Modul Pattern Match • Module Math rounding error • Firmwareupdate can fail in special situations 	<p>Projects: 1.4.x</p> <p>Firmware: 1.4.x</p>
1.4.3	13.12.17	<p>Features:</p> <ul style="list-style-type: none"> • Pattern matching module: Extended teach-in and timeout performance <p>Bug fixes:</p> <ul style="list-style-type: none"> • FTP connection • Memory assignment in the cluster module • Pattern matching module: Detected patterns correspond with the results list • Memory handling in the 1D code module • Teach+ with display device 	<p>Projects: 1.4.x</p> <p>Firmware: 1.4.x</p>

Version	Release date	Description / changes	Compatibility
1.4.4	03.04.18	<ul style="list-style-type: none">• Compatible with new flash memory Bug fixes: <ul style="list-style-type: none">• Optimizations for displaying the website at HMIs• Correction of angles indicated in the pattern matching module Note! <ul style="list-style-type: none">• After updating the device to this version, downgrading to a lower firmware version is no longer possible (see section “8.3. Upgrade and Downgrade Options” on page 38).	Projects: 1.4.x Firmware: 1.4.x
1.4.5	20.07.18	Bug fixes: <ul style="list-style-type: none">• Improved Profinet behavior after a reconnect Note! <ul style="list-style-type: none">• After updating the device to this version, downgrading to a lower firmware version is no longer possible (see section “8.3. Upgrade and Downgrade Options” on page 38).	Projects: 1.4.x Firmware 1.4.x

18.8.2. Software changelog

Version	Release date	Description / changes	Compatibility
1.0.4	27.01.14	Initial market launch version. This software version was delivered on the CDs with the first products	Projects: 1.0.x PC Software: 1.0.x
1.0.7	18.02.14	Final market launch version Features: <ul style="list-style-type: none"> • Introduction of project template files • Update of the training demo files • Enhancements of the Module Image Comparison visualization Bug fixes: <ul style="list-style-type: none"> • FTP connection • Timeout handling • Minor bug fixes (see bugzilla for details) 	Projects: 1.0.x PC Software: 1.0.x
1.1.0	26.05.14	First minor release Features: <ul style="list-style-type: none"> • Magic Wand for Module Threshold and Module Threshold HSV • Enhanced parameters for Module Code 1D/2D • Special character editor for e.g. Device Communication • Text edit supports scientific format • Optimization of the „Advanced Mode“ Bug fixes: <ul style="list-style-type: none"> • FTP • Updater • Teach⁺ downloader • License file • Memory leaks • Timeout handling e.g. loading of complex project files • Minor bug fixes (see bugzilla for details) Updates: <ul style="list-style-type: none"> • USB dongle driver V6.6 	Projects: 1.1.x/1.0.x PC Software: 1.1.x/1.0.x
1.1.1	26.05.14	Features: <ul style="list-style-type: none"> • Text edit supports scientific format Bug fixes: <ul style="list-style-type: none"> • Memory leaks • Minor bug fixes 	Projects: 1.1.x/1.0.x PC Software: 1.1.x/1.0.x

Version	Release date	Description / changes	Compatibility
1.1.5	09.09.14	Features: <ul style="list-style-type: none"> • Signed installer • „Download“ link • New parameters in Module Application: Process Time Last Run; Module State Last Run • New clean up functionality after deleting a tool in the Module Measure → tool dependencies are checked and all related tools will be removed. Bug fixes: <ul style="list-style-type: none"> • Loading .w_r file fails if path contains special characters like „ä“ • Minor bug fixes 	Projects: 1.1.x/1.0.x PC Software: 1.1.x/1.0.x
1.1.6	08.12.14	Bug fixes: <ul style="list-style-type: none"> • Image defects, small image excerpts • Streaks in the image / dark images after restarting • Image comparison module • Barcode module: sporadic no-reads • Different results with the same image defects • LIMA run command • Flash memory 	Projects: 1.1.x / 1.0.x PC Software: 1.1.x / 1.0.x
1.1.7	12.12.14	Bug fixes: <ul style="list-style-type: none"> • Faulty read-out of the 1D code license file 	Projects: 1.1.x / 1.0.x PC Software: 1.1.x / 1.0.x
1.2.0	23.02.15	Minor release. Features: <ul style="list-style-type: none"> • Device Camera: New image acquisition is independent from the algorithm processing as long the image buffer (10 images) does have free capacity. • Device Camera: Illumination setting can be linked (Light Internal, Light External) • Device Camera: ProfiNet Trigger • Device Communication (Digital Output): Forced to the enhancements in the Device Camera the "Ready" digital output is no longer supported the way it was in earlier versions. New flags "Process" and "Capture" are available in new projects. If you load a version 1.1.x or earlier in the sensor, the deprecated "Ready" output keeps in the project tree as is. In this case the sensor hardware signals the "Ready" flag as a "Process" flag! • Device Display: Linking the I/O states to the Device Display • Device IO Unit: Project change by digital I/O control • Module Code 1D: Property "Read Timeout" unit changed from [s] to [ms]. Conversion is automatically done if needed. 	Projects: 1.2.x / 1.2.x PC Software: 1.2.x / 1.2.x

Version	Release date	Description / changes	Compatibility
1.2.0	23.02.15	<ul style="list-style-type: none"> • Module Code 1D: Advanced settings • Module Code 2D: Property "Read Timeout" unit changed from [s] to [ms]. Conversion is automatically done if needed. • Module Measure: New tools <ul style="list-style-type: none"> Find Arc Segments on Line Segments on Circle Segments on Arc • Module Coordinate System: New tools <ul style="list-style-type: none"> Edge on Arc Segment on Line Segment on Circle Segment on Arc • Linkable point (you may use a point calculated by any tool in the tree e.g. Center of Gravity of the Module Cluster) • Module Application: Project Version • Module Localizer: Search Box can be resized now. Performance warning! • Error handling for communication devices (value substitution) • Teach+: New data: <ul style="list-style-type: none"> Device type (article number) IP settings • Teach+: File name time stamp support • LIMA communication over RS232 • GUI: Online Data Monitoring: <ul style="list-style-type: none"> Digital I/O status Available memory chart Processing time chart • GUI: User account support • GUI: Manual trigger by the user (press the key "t") • GUI: Rename support of tools (Device, Module) in the project tree Updates: <ul style="list-style-type: none"> • Translations 	Projects: 1.2.x / 1.2.x PC Software: 1.2.x / 1.2.x
1.2.2	12.06.15	Patch release Bug fixes: <ul style="list-style-type: none"> • Searching for connected sensors failed in case of a different subnet mask • Module Measure: No calculation in some complex project configurations • Decimal separator • No zooming of modifiers, characters etc. from now on • Minor bug fixes • Translations 	Projects: 1.2.x Firmware: 1.2.x

Version	Release date	Description / changes	Compatibility
1.3.0	17.11.15	<p>Minor Release</p> <p>Features:</p> <p>Localization/ translations: Complete support of English, Chinese, Turkey, Hungarian, Dutch, Portuguese, Spanish, Italian, German, French</p> <p>Project converter</p> <p>Application starter for all supported project versions</p> <p>File association support: *.w_p, *.w_r, *.w_t</p> <p>Move Copy Paste of modules in the project tree. (Info: Devices can not be copied due to hardware dependencies)</p> <p>Visualization of Device Indicator status in the Image Container Viewer</p> <p>Visibility handling of selected tools</p> <p>Open dialog supports all file type filters</p> <p>Default project name at "Save as..."</p> <p>Path of node by right click on node (Advanced Mode needs to be activated)</p> <p>Minor logging support</p> <p>Bug fixes:</p> <p>Minor bug fixes</p> <p>Updates:</p> <p>Manuals, English and German</p> <p>Localization/ translations</p>	<p>Projects: 1.x.x</p> <p>Firmware: 1.3.0</p>
1.3.1	26.02.16	<p>Bug fixes:</p> <ul style="list-style-type: none"> • Application crash by drag and drop action of modules in the Navigator view. This occurs in combination with special characters only! • Device Camera Readout Box representation when Subsampling active • Double Min and Max values available after project load • Rounding of double data editor • Update training demos • Project preview works in online mode 	<p>Projects: 1.1.x</p> <p>Firmware: 1.3.x</p>
1.3.2	29.04.16	<p>Bug fixes:</p> <ul style="list-style-type: none"> • Update Manual section Module Threshold • OCR Multiline correct segmentation of 2nd line • Link list do not allow illegal links 	<p>Projekte 1.1.x</p> <p>Firmware 1.3.x</p>

Version	Release date	Description / changes	Compatibility
1.4.0	17.02.17	Minor Release Functions: <ul style="list-style-type: none"> • Rotation of the input image • White balancing (color version) • Toggle bit • Pattern matching • Industrial Ethernet, new data types • Measuring module, point usage • Logic module, several inputs • Math module, several inputs • Extended temperature range Updates: <ul style="list-style-type: none"> • Operating instructions • Translations 	Projects: 1.1.x Firmware: 1.4.x
1.4.1	---	---	---
1.4.2	03.05.17	Bug fix release: Features: Module Pattern Match – Activation of the Pattern Match model editor functionality. Bug fixes: <ul style="list-style-type: none"> • Project Converter – Several issues. Note: Reconvert projects from 1.3 to 1.4 with the latest converter to fix these issues! • Module Pattern Match – Teach by general I/O action input fixed. • Minor bug fixes and performance optimizations. Updates: Manuals, English, German, Italian Localization/ translations	Projects: 1.1.x Firmware: 1.4.x
1.4.3	13.12.17	Features: <ul style="list-style-type: none"> • Pattern matching module: Extended teach-in and timeout performance Bug fixes: <ul style="list-style-type: none"> • FTP connection • Memory assignment in the cluster module • Pattern matching module: Detected patterns correspond with the results list • Memory handling in the 1D code module • Teach+ with display device 	Projects: 1.4.x Firmware: 1.4.x

Version	Release date	Description / changes	Compatibility
1.4.4	03.04.18	<ul style="list-style-type: none"> • Compatible with new flash memory Bug fixes: <ul style="list-style-type: none"> • Optimizations for displaying the website at HMIs • Correction of angles indicated in the pattern matching module <p>Note! After updating the device to this version, downgrading to a lower firmware version is no longer possible (see section “8.3. Upgrade and Downgrade Options” on page 38).</p>	Projects: 1.4.x Firmware: 1.4.x
1.4.5	20.07.18	Bug fixes: <ul style="list-style-type: none"> • Improved Profinet behavior after a reconnect • Improved behavior at firmware updates <p>Note! After updating the device to this version, downgrading to a lower firmware version is no longer possible (see section “8.3. Upgrade and Downgrade Options” on page 38).</p>	Projets 1.4.x Firmware 1.4.x

19. EU Declaration of Conformity

The EU declaration of conformity can be found on our website at www.wenglor.com in download area.