

# Inductive Sensor with IO-Link

## I08H025

Part Number

weproTec



- Easy sensor configuration using the IO-Link interface
- Innovative ASIC circuit technology
- Integrated error display and error output
- Minimal mounting clearance thanks to wenglor weproTec

The Inductive Sensors have not only been equipped with ASIC, but rather with an IO-Link interface as well for ideal integration into networks. As a result, a total of three switching distances and two switching frequencies can be selected, and PNP/NPN as well as NO/NC/antivalent options can be set as desired. This reduces the number of variants while simultaneously expanding the scope of functions.

### Technical Data

Inductive Data	
Switching Distance	4 mm
Standard Target	12 × 12 mm
Correction Factors Stainless Steel V2A/CuZn/Al	1,07/0,50/0,48
Mounting	semi-flush
Mounting A/B/C/D in mm	8/17/12/3
Mounting B1 in mm	0...6
Switching Hysteresis	< 10 %

Electrical Data	
Supply Voltage	10...30 V DC
Supply Voltage with IO-Link	18...30 V DC
Current Consumption (U <sub>b</sub> = 24 V)	< 12 mA
Switching Frequency	760 Hz
Temperature Drift	< 10 %
Temperature Range	-40...80 °C
Switching Output Voltage Drop	< 1 V
Switching Output/Switching Current	150 mA
Residual Current Switching Output	< 100 µA
Short Circuit Protection	yes
Reverse Polarity and Overload Protection	yes
Interface	IO-Link V1.0
Protection Class	III

Mechanical Data	
Housing Material	CuZn, nickel-plated
Degree of Protection	IP67
Connection	M12 × 1; 4-pin

Safety-relevant Data	
MTTFd (EN ISO 13849-1)	3706,54 a

Function	
Error Indicator	yes
Programmable switching distance	2,5/3/4 mm
Programmable switching frequency	yes

IO-Link	●
Switchable to NC/NO	●
Configurable as PNP/NPN/Push-Pull	●
Programmable error output	●

Connection Diagram No.	704
Suitable Connection Technology No.	2
Suitable Mounting Technology No.	200   202

### Complementary Products

IO-Link Master Software
-------------------------

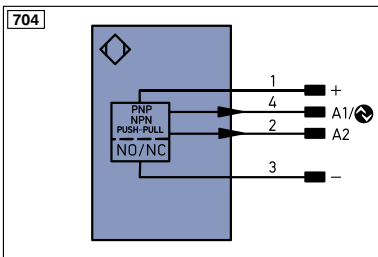
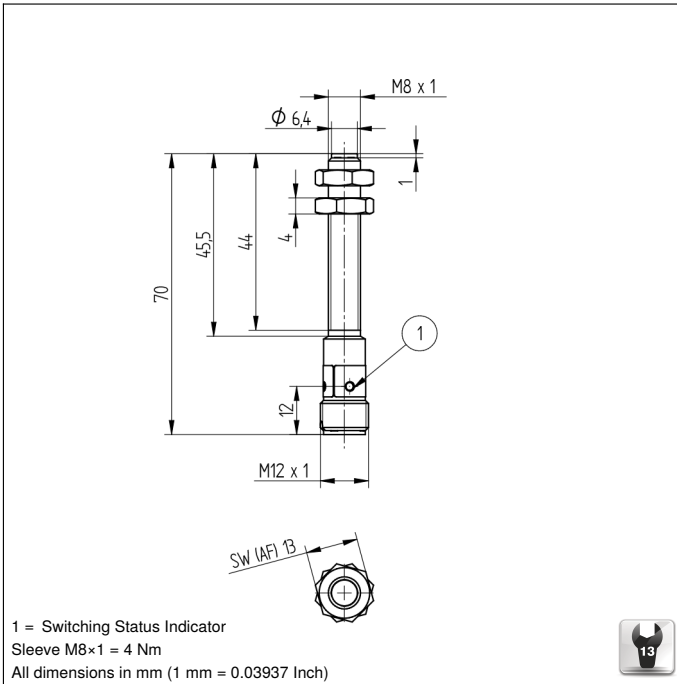

Legend		Legend		Legend	
+	Supply Voltage +	PT	Platinum measuring resistor	ENa	Encoder A
-	Supply Voltage 0 V	nc	not connected	ENb	Encoder B
~	Supply Voltage (AC Voltage)	U	Test Input	AMIN	Digital output MIN
A	Switching Output (NO)	U	Test Input inverted	AMAX	Digital output MAX
Ā	Switching Output (NC)	W	Trigger Input	AOK	Digital output OK
V	Contamination/Error Output (NO)	O	Analog Output	SY In	Synchronization In
Ṽ	Contamination/Error Output (NC)	O-	Ground for the Analog Output	SY OUT	Synchronization OUT
E	Input (analog or digital)	BZ	Block Discharge	Out	Brightness output
T	Teach Input	Aw	Valve Output	M	Maintenance
Z	Time Delay (activation)	a	Valve Control Output +		
S	Shielding	b	Valve Control Output 0 V		
RxD	Interface Receive Path	SY	Synchronization		
TxD	Interface Send Path	E+	Receiver-Line		
RDY	Ready	S+	Emitter-Line		
GND	Ground	≡	Grounding		
CL	Clock	SnR	Switching Distance Reduction		
E/A	Output/Input programmable	Rx+/-	Ethernet Receive Path		
IO-Link	IO-Link	Tx+/-	Ethernet Send Path		
PoE	Power over Ethernet	Bus	Interfaces-Bus A(+)/B(-)		
IN	Safety Input	La	Emitted Light disengageable		
OSSD	Safety Output	Mag	Magnet activation		
Signal	Signal Output	RES	Input confirmation		
Bl..D+/-	Ethernet Gigabit bidirect. data line (A-D)	EDM	Contacting Monitoring		
EN0..5422	Encoder 0-pulse 0-0 (TTL)	ENAR5422	Encoder A/Ā (TTL)		
		ENBR5422	Encoder B/B̄ (TTL)		

### Wire Colors according to DIN IEC 757

BK	Black
BN	Brown
RD	Red
OG	Orange
YE	Yellow
GN	Green
BU	Blue
VT	Violet
GY	Grey
WH	White
PK	Pink
GNYE	Green/Yellow

## Mounting

