

# Inductive Sensor with Increased Switching Distance

## I1DH008

Part Number

weproTec



- Increased switching distance
- Innovative ASIC circuit technology
- Integrated error display
- Minimal mounting clearance thanks to wenglor weproTec

Inductive Sensors with increased switching distances are distinguished by rugged design, easy installation and reliable measured values. The large range makes additional types of sensor superfluous because they can also be used to implement special applications. In addition to error-free operation of several sensors in a very small space, the new generation also provides the possibility of detecting system errors before it's too late thanks to ASIC und wenglor weproTec.

### Technical Data

Inductive Data	
Switching Distance	10 mm
Correction Factors Stainless Steel V2A/CuZn/Al	1,06/0,56/0,52
Mounting	non-flush
Mounting A/B/C/D in mm	72/14/30/10
Mounting B1 in mm	0...12
Switching Hysteresis	< 10 %
Electrical Data	
Supply Voltage	10...30 V DC
Current Consumption (U <sub>b</sub> = 24 V)	< 10 mA
Switching Frequency	460 Hz
Temperature Drift	< 10 %
Temperature Range	-40...80 °C
Switching Output Voltage Drop	< 1 V
Switching Output/Switching Current	150 mA
Residual Current Switching Output	100 µA
Short Circuit Protection	yes
Reverse Polarity and Overload Protection	yes
Protection Class	III
Mechanical Data	
Housing Material	Plastic
Degree of Protection	IP67/IP68
Connection	M8 × 1; 3-pin
Safety-relevant Data	
MTTFd (EN ISO 13849-1)	3706,54 a
Diagnostic Coverage (DC)	0 %
Service Life TM (EN ISO 13849-1)	20 a
Function	
Error Indicator	yes
NPN NC	●
Connection Diagram No.	309
Suitable Connection Equipment No.	8

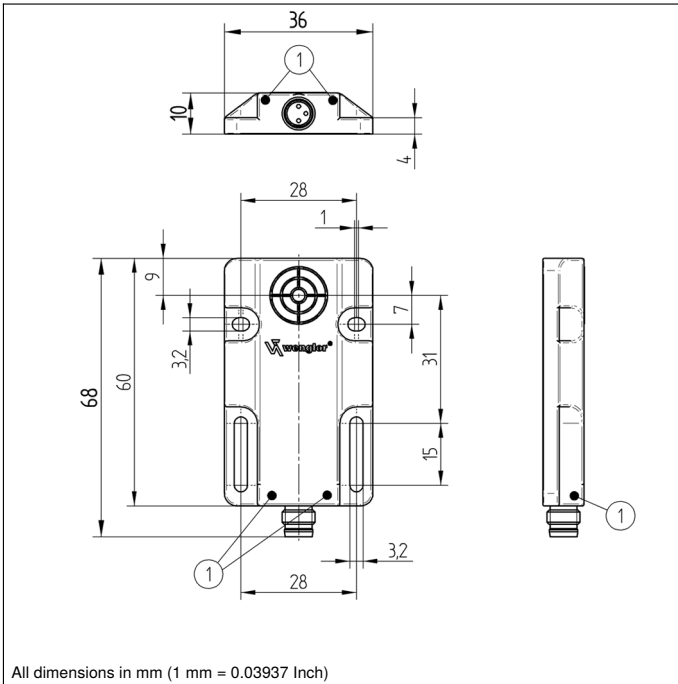

All dimensions in mm (1 mm = 0.03937 Inch)

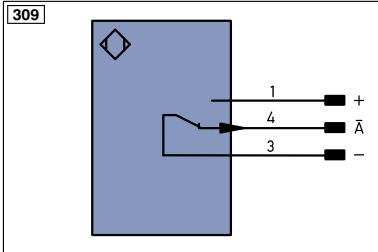

### Legend

<b>+</b> Supply Voltage +	<b>nc</b> not connected	<b>ENa</b> Encoder A
<b>-</b> Supply Voltage 0 V	<b>U</b> Test Input	<b>ENb</b> Encoder B
<b>~</b> Supply Voltage (AC Voltage)	<b>U</b> Test Input inverted	<b>AMIN</b> Digital output MIN
<b>A</b> Switching Output (NO)	<b>W</b> Trigger Input	<b>AMAX</b> Digital output MAX
<b>Ā</b> Switching Output (NC)	<b>O</b> Analog Output	<b>AOK</b> Digital output OK
<b>V</b> Contamination/Error Output (NO)	<b>O-</b> Ground for the Analog Output	<b>SY In</b> Synchronization In
<b>V̄</b> Contamination/Error Output (NC)	<b>BZ</b> Block Discharge	<b>SY OUT</b> Synchronization OUT
<b>E</b> Input (analog or digital)	<b>AWV</b> Valve Output	<b>Ort</b> Brightness output
<b>T</b> Teach Input	<b>a</b> Valve Control Output +	<b>M</b> Maintenance
<b>Z</b> Time Delay (activation)	<b>b</b> Valve Control Output 0 V	<b>rsv</b> reserved
<b>S</b> Shielding	<b>SY</b> Synchronization	
<b>RxD</b> Interface Receive Path	<b>E+</b> Receiver-Line	
<b>TxD</b> Interface Send Path	<b>S+</b> Emitter-Line	
<b>RDY</b> Ready	<b>≡</b> Grounding	
<b>GND</b> Ground	<b>SnR</b> Switching Distance Reduction	
<b>CL</b> Clock	<b>Rx+/-</b> Ethernet Receive Path	
<b>E/A</b> Output/Input programmable	<b>Tx+/-</b> Ethernet Send Path	
 <b>IO-Link</b>	<b>Bus</b> Interfaces-Bus A(+)/B(-)	
<b>PoE</b> Power over Ethernet	<b>La</b> Emitted Light disengageable	
<b>IN</b> Safety Input	<b>Mag</b> Magnet activation	
<b>OSSD</b> Safety Output	<b>RES</b> Input confirmation	
<b>Signal</b> Signal Output	<b>EDM</b> Contactor Monitoring	
<b>Bl..D+/-</b> Ethernet Gigabit bidirect. data line (A-D)	<b>ENaRS422</b> Encoder A/Ā (TTL)	
<b>EN0RS422</b> Encoder 0-pulse 0-0 (TTL)	<b>ENbRS422</b> Encoder B/B̄ (TTL)	

### Wire Colors according to DIN IEC 757

<b>BK</b> Black
<b>BN</b> Brown
<b>RD</b> Red
<b>OG</b> Orange
<b>YE</b> Yellow
<b>GN</b> Green
<b>BU</b> Blue
<b>VT</b> Violet
<b>GY</b> Grey
<b>WH</b> White
<b>PK</b> Pink
<b>GNYE</b> Green/Yellow

## Mounting

