

3D Sensor

MLAS103

Part Number

ShapeDrive



- 10 Gbit/s interface for high speed data transfer
- 5 MP resolution
- Short recording times of up to 0.188 s

ShapeDrive MLAS 3D Sensors are distinguished by high precision for minimal measuring volumes. The ten models in this series are available in two performance classes with camera resolutions of 5 and 12 megapixels. All ShapeDrive sensors are ideally suited for use in industrial environments thanks to the rugged IP65 housing. With its 10 Gigabit Ethernet interface and five measuring ranges in each performance class, ShapeDrive is also distinguished by great diversity and high speed.

Technical Data

Optical Data	
Working range Z	225...315 mm
Measuring range Z	90 mm
Measuring range X	120 mm
Measuring range Y	90 mm
Resolution Z	10 µm
Resolution X/Y	49 µm
Camera Resolution	2448 × 2048 Pixel
Light Source	LED (blue)
Wavelength	460 nm
Service Life (T = +25 °C)	20000 h
Risk Group (EN 62471)	2
Max. Ambient Light	5000 Lux
Electrical Data	
Supply Voltage	18...30 V DC
Max. Current Consumption (Ub = 24 V)	3,5 A
Recording duration	0,188...0,61 s
Temperature Range	0...35 °C
Storage temperature	-5...70 °C
Short Circuit Protection	yes
Reverse Polarity Protection	yes
Interface	Ethernet TCP/IP
Baud Rate	100 Mbit/s
Baud Rate (10 GbE)	10 Gbit/s
Protection Class	III
Mechanical Data	
Housing Material	Aluminium; Plastic
Degree of Protection	IP65
Connection	M12 × 1; 12-pin
Type of Connection Ethernet	M12 × 1; 8-pin, X-cod.
Optic Cover	Plastic
Weight	2500 g
Web server	yes
Connection Diagram No.	238 1022
Control Panel No.	A41
Suitable Connection Equipment No.	50 87
Suitable Mounting Technology No.	343



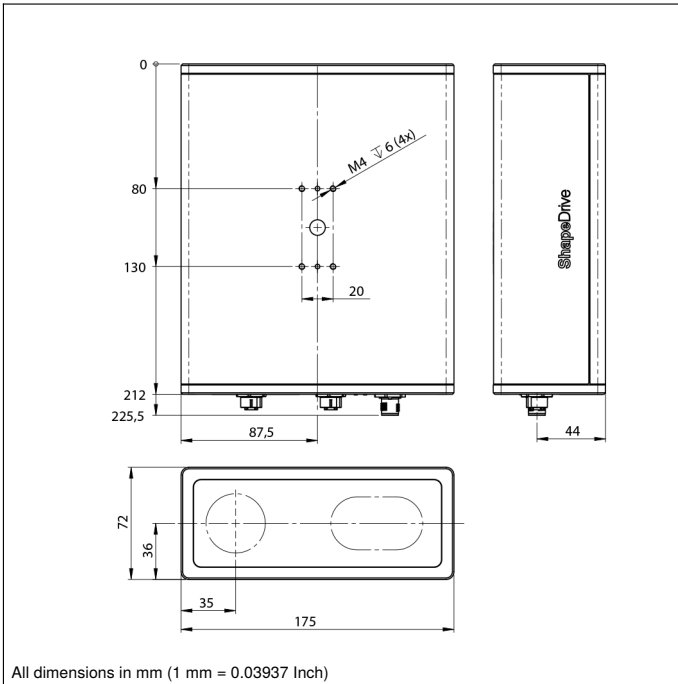

Ctrl. Panel

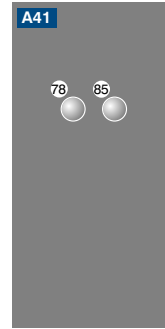

78 = Module status
85 = Link/Act LED

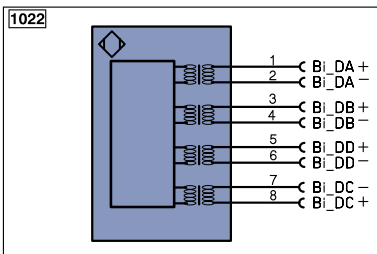
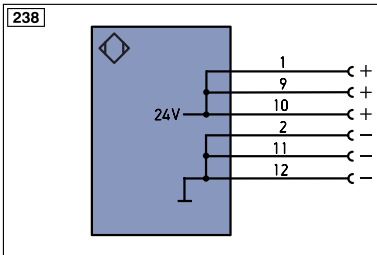

Legend

+	Supply Voltage +	PT	Platinum measuring resistor	EN ^{A/RS422}	Encoder A/Ā (TTL)
-	Supply Voltage 0 V	nc	not connected	EN ^{B/RS422}	Encoder B/B̄ (TTL)
~	Supply Voltage (AC Voltage)	U	Test Input	EN _A	Encoder A
A	Switching Output (NO)	Ū	Test Input inverted	EN _B	Encoder B
Ā	Switching Output (NC)	W	Trigger Input	A _{MIN}	Digital output MIN
V	Contamination/Error Output (NO)	W-	Ground for the Trigger Input	A _{MAX}	Digital output MAX
Ṽ	Contamination/Error Output (NC)	O	Analog Output	A _{OK}	Digital output OK
E	Input (analog or digital)	O-	Ground for the Analog Output	SY _{in}	Synchronization In
T	Teach Input	BZ	Block Discharge	SY _{OUT}	Synchronization OUT
Z	Time Delay (activation)	A _{WV}	Valve Output	OL _T	Brightness output
S	Shielding	a	Valve Control Output +	M	Maintenance reserved
RxD	Interface Receive Path	b	Valve Control Output 0 V	rsv	reserved
TxD	Interface Send Path	SY	Synchronization	Wire Colors according to DIN IEC 757	
RDY	Ready	SY-	Ground for the Synchronization	BK	Black
GND	Ground	E+	Receiver-Line	BN	Brown
CL	Clock	S+	Emitter-Line	RD	Red
E/A	Output/Input programmable	±	Grounding	OG	Orange
IO-Link	IO-Link	S _{nR}	Switching Distance Reduction	YE	Yellow
PoE	Power over Ethernet	Rx+/-	Ethernet Receive Path	GN	Green
IN	Safety Input	Tx+/-	Ethernet Send Path	BU	Blue
OSSD	Safety Output	Bus	Interfaces-Bus A(+)/B(-)	VT	Violet
Signal	Signal Output	L _a	Emitted Light disengageable	GY	Grey
Bi_D+/-	Ethernet Gigabit bidirect. data line (A-D)	Mag	Magnet activation	WH	White
EN ^{0/RS422}	Encoder 0-pulse 0-0̄ (TTL)	RES	Input confirmation	PK	Pink
		EDM	Contactur Monitoring	GN _{YE}	Green/Yellow

Measuring Volume

