

# 2D/3D Profile Sensor

## MLSL134 LASER

Part Number

weCat3D



- Blue light for applications on metal, organic or semi-transparent materials
- Compact, lightweight design – even suitable for robot applications
- Precise resolution of visual field width X (> 1200 measuring points)
- Up to 3.6 million measuring points per second

2D/3D Profile Sensors project a laser line onto the object to be detected and generate an accurate, linearized height profile with an internal camera which is set up at a triangulation angle. Thanks to its uniform, open interface, the weCat3D series can be incorporated by means of the DLL program library or the GigE Vision standard without an additional control unit. Alternatively, wenglor offers its own software packages for implementing your application.

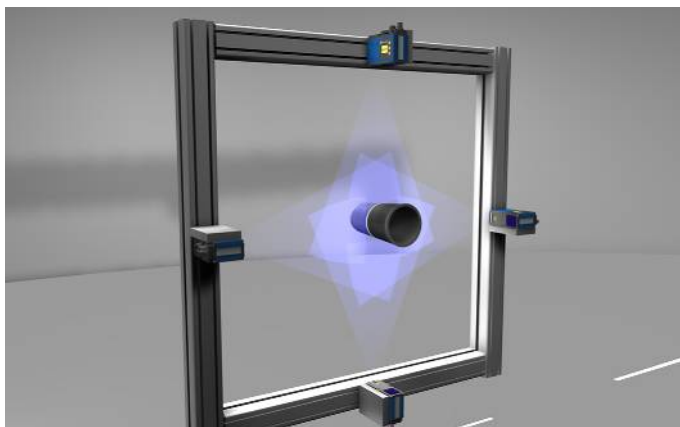

### Technical Data

Optical Data	
Working range Z	100...500 mm
Measuring range Z	400 mm
Visual field width X	70...280 mm
Linearity Deviation	200 µm
Resolution Z	12,4...160 µm
Resolution X	68...246 µm
Light Source	Laser (blue)
Wave Length	405 nm
Service Life (T = +25 °C)	20000 h
Laser Class (EN 60825-1)	2M
Max. Ambient Light	5000 Lux
Electrical Data	
Supply Voltage	18...30 V DC
Current Consumption (U <sub>b</sub> = 24 V)	300 mA
Measuring Rate	200...4000 /s
Temperature Range	0...45 °C
Storage temperature	-20...70 °C
Inputs/Outputs	4
Switching Output Voltage Drop	< 1,5 V
Switching Output/Switching Current	100 mA
Short Circuit Protection	yes
Reverse Polarity Protection	yes
Overload Protection	yes
Interface	Ethernet TCP/IP
Baud Rate	100/1000 Mbit/s
Protection Class	III
FDA Accession Number	1610467-001
Mechanical Data	
Housing Material	Aluminium; Plastic
Degree of Protection	IP67
Connection	M12 × 1; 12-pin
Type of Connection Ethernet	M12 × 1; 8-pin, X-cod.
Optic Cover	Plastic
Weight	290 g
Web server	yes
Configurable as PNP/NPN/Push-Pull	<input checked="" type="checkbox"/>
Switchable to NC/NO	<input checked="" type="checkbox"/>
Connection Diagram No.	<b>1022</b> <b>1023</b>
Control Panel No.	<b>X2</b> <b>A22</b>
Suitable Connection Technology No.	<b>50</b> <b>87</b>
Suitable Mounting Technology No.	<b>343</b>

Display brightness may decrease with age. This does not result in any impairment of the sensor function.

### Complementary Products

Control Unit	
Cooling Unit ZLSK001	
Protective Housing ZLSS003	
Protective Screen Retainer ZLSS001	
Software	
Switch ZAC45FN01	

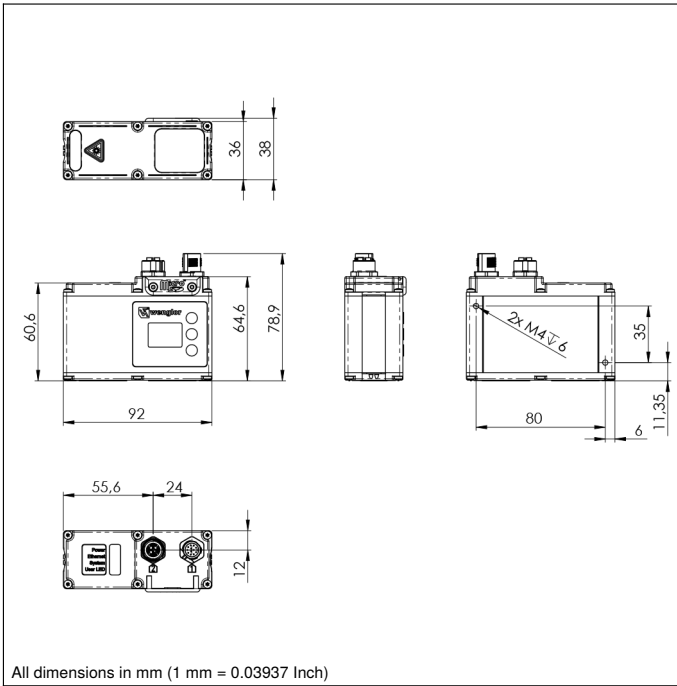

### Ctrl. Panel



- 20 = Enter Button
- 22 = UP Button
- 23 = Down Button
- 4a = User LED
- 60 = Display
- 68 = Supply Voltage Indicator
- 78 = Module status
- 85 = Link/Act LED



### Legend

+	Supply Voltage +	PT	Platinum measuring resistor	ENa	Encoder A
-	Supply Voltage 0 V	nc	not connected	ENb	Encoder B
~	Supply Voltage (AC Voltage)	U	Test Input	AMIN	Digital output MIN
A	Switching Output (NO)	U	Test Input inverted	AMAX	Digital output MAX
Ā	Switching Output (NC)	W	Trigger Input	AOK	Digital output OK
V	Contamination/Error Output (NO)	O	Analog Output	SY In	Synchronization In
V̄	Contamination/Error Output (NC)	O-	Ground for the Analog Output	SY OUT	Synchronization OUT
E	Input (analog or digital)	BZ	Block Discharge	Out	Brightness output
T	Teach Input	AWV	Valve Output	M	Maintenance
Z	Time Delay (activation)	a	Valve Control Output +		
S	Shielding	b	Valve Control Output 0 V		
RxD	Interface Receive Path	SY	Synchronization		
TxD	Interface Send Path	E+	Receiver-Line		
RDY	Ready	S+	Emitter-Line		
GND	Ground	≡	Grounding		
CL	Clock	SnR	Switching Distance Reduction		
E/A	Output/Input programmable	Rx+/-	Ethernet Receive Path		
IO-Link	IO-Link	Tx+/-	Ethernet Send Path		
PoE	Power over Ethernet	Bus	Interfaces-Bus A(+)/B(-)		
IN	Safety Input	La	Emitted Light disengageable		
OSSD	Safety Output	Mag	Magnet activation		
Signal	Signal Output	RES	Input confirmation		
Bi_D+/-	Ethernet Gigabit bidirect. data line (A-D)	EDM	Contactur Monitoring		
EN0 RS422	Encoder 0-pulse 0-0 (TTL)	ENAR5422	Encoder A/Ā (TTL)		
		ENBR5422	Encoder B/B̄ (TTL)		

### Wire Colors according to DIN IEC 757

BK	Black
BN	Brown
RD	Red
OG	Orange
YE	Yellow
GN	Green
BU	Blue
VT	Violet
GY	Grey
WH	White
PK	Pink
GNYE	Green/Yellow

### Visual Field X, Z

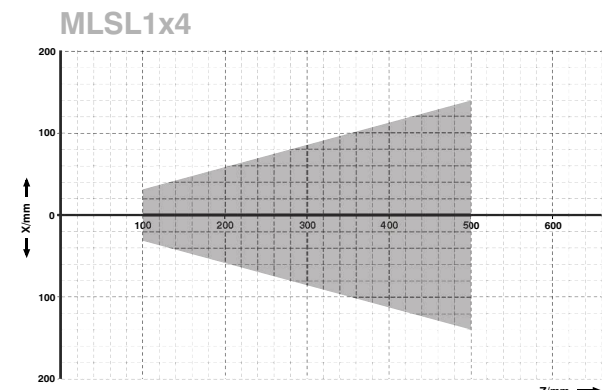

Z = Working distance

X = Visual field width

