

Guard Locking Device

Electromagnetic, Power to Lock Principle

SD4ICS02SE89

Part Number



- 500 N locking force (monitored)
- Easy to clean
- Extensive diagnosis
- Integrated locking

This innovative guard locking device is suitable for process safety thanks to the constantly monitored locking force. Also, the safety level cat. 4 PL e (EN ISO 13849-1) can be achieved with just one guard locking device and is retained even during series connection. Response and risk times remain unchanged during series connection. Extensive diagnosis functions boost system availability and make installation and maintenance easier. Thanks to the electrical locking, no touching components whatsoever are used and therefore wear, the guard door clattering (and rattling) loudly and laborious cleaning work are avoided.

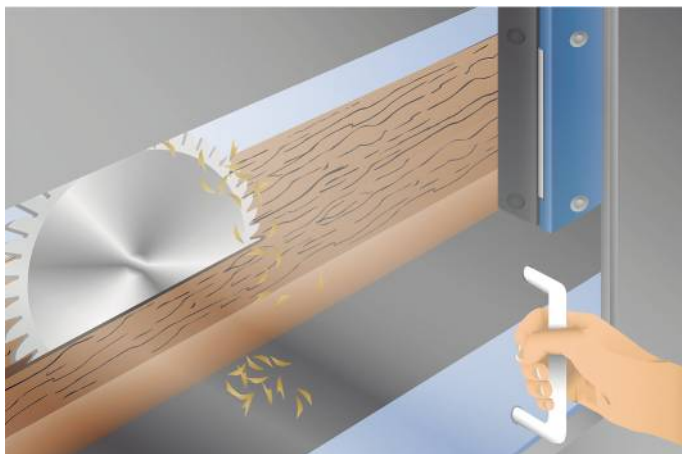

Technical Data

Electrical Data	
Sensor Type	Locking unit
Supply Voltage	20,4...26,4 V DC
Response Time	< 150 ms
Risk time	< 150 ms
Temperature Range	-25...55 °C
Storage temperature	-25...85 °C
Safety Output	OSSD
No. Safety Outputs (OSSDs)	2
PNP Safety Output/Switching Current	< 250 mA
Signal Outputs	1
PNP signal output switching current	< 50 mA
Short Circuit Protection	yes
Protection Class	II

Mechanical Data	
Housing Material	Plastic
Degree of Protection	IP67
Connection	M12 × 1; 8-pin
Detent force, typical	15 N

Safety-relevant Data	
Operating principle	Inductively coded
Coding	Standard
Performance Level (EN ISO 13849-1)	Cat. 4 PL e
PFHD	3,50 × E-9 1/h
Safety Integrity Level (EN 61508)	SIL3
Safety Integrity Level (EN 62061)	SILCL3
PDDb (EN 60947-5-3)	yes
Lock	Power to lock principle
Locking Force F, guaranteed	500 N
Locking Force Fmax, typical	750 N

Function	
Series connection	yes
Monitored lock	yes
Permanent magnet	yes

Applicable actuator	SD4ICA01
---------------------	----------

Connection Diagram No.	P03
Suitable Connection Technology No.	89
Suitable Mounting Technology No.	830

Complementary Products

Safety Relay SR4B3B01S, SR4D3B01S
Software

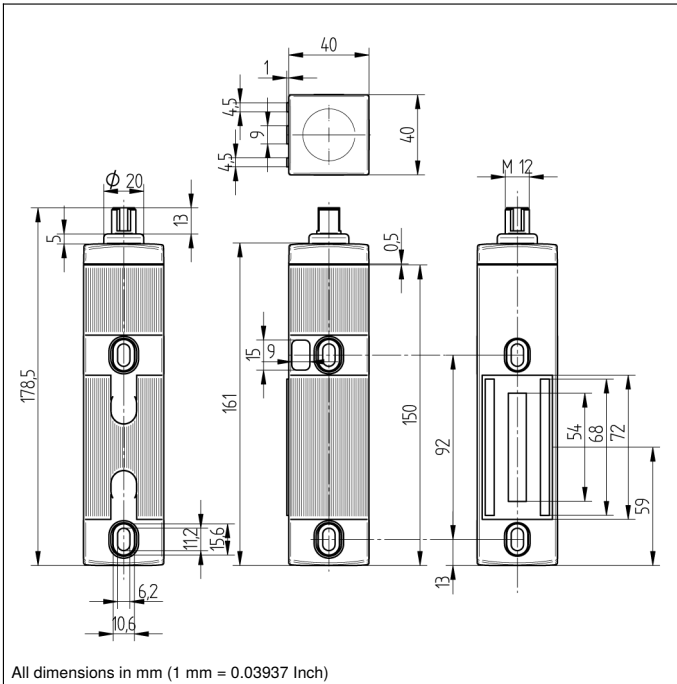

All dimensions in mm (1 mm = 0.03937 Inch)

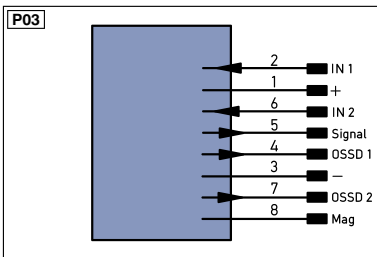

Legend

+ Supply Voltage +	PT Platinum measuring resistor	ENa Encoder A
- Supply Voltage 0 V	nc not connected	ENb Encoder B
~ Supply Voltage (AC Voltage)	U Test Input	AMIN Digital output MIN
A Switching Output (NO)	U Test Input inverted	AMAX Digital output MAX
Ā Switching Output (NC)	W Trigger Input	AOK Digital output OK
V Contamination/Error Output (NO)	O Analog Output	SY In Synchronization In
∇ Contamination/Error Output (NC)	O- Ground for the Analog Output	SY OUT Synchronization OUT
E Input (analog or digital)	BZ Block Discharge	Out Brightness output
T Teach Input	AW Valve Output	M Maintenance
Z Time Delay (activation)	a Valve Control Output +	
S Shielding	b Valve Control Output 0 V	
RxD Interface Receive Path	SY Synchronization	
TxD Interface Send Path	E+ Receiver-Line	
RDY Ready	S+ Emitter-Line	
GND Ground	≡ Grounding	
CL Clock	SnR Switching Distance Reduction	
E/A Output/Input programmable	Rx+/- Ethernet Receive Path	
 IO-Link	Tx+/- Ethernet Send Path	
PoE Power over Ethernet	Bus Interfaces-Bus A(+)/B(-)	
IN Safety Input	La Emitted Light disengageable	
OSSD Safety Output	Mag Magnet activation	
Signal Signal Output	RES Input confirmation	
Bl..D +/- Ethernet Gigabit bidirect. data line (A-D)	EDM Contactor Monitoring	
EN0-R5422 Encoder 0-pulse 0-0 (TTL)	ENAR5422 Encoder A/Ā (TTL)	
	ENBR5422 Encoder B/B̄ (TTL)	

Wire Colors according to DIN IEC 757

BK Black
BN Brown
RD Red
OG Orange
YE Yellow
GN Green
BU Blue
VT Violet
GY Grey
WH White
PK Pink
GNYE Green/Yellow

