

High-Performance Distance Sensor

UMS603U035

Part Number



- Digital and analog output
- Menu-driven settings
- Synchronous and multiplex mode
- Temperature drift eliminable

These ultrasonic sensors evaluate the sound reflected by the object. They detect almost every object and are suited especially for the filling level monitoring of fluids or bulk material or the detection of transparent objects. The sensor detects objects independent from their material, aggregate state, color or transparency. The graphic display enables easy, menu-driven sensor setup. Convenient programming and quick diagnosis is possible via the IO-Link interface.

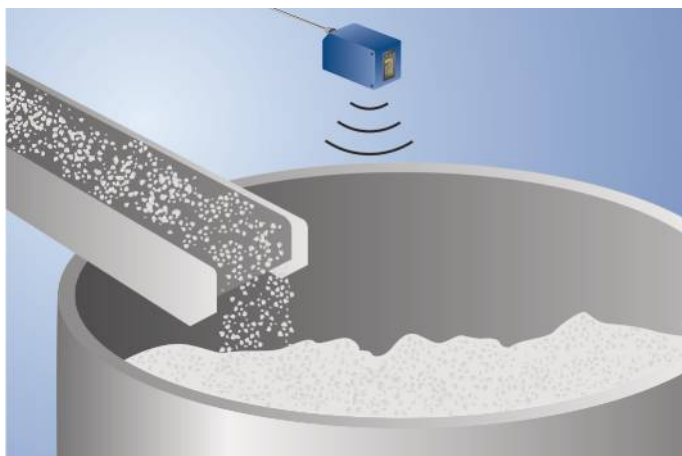

Technical Data

Ultrasonic Data	
Working Range	300...6000 mm
Measuring Range	5700 mm
Reproducibility maximum	5 mm
Linearity Deviation	20 mm
Resolution	1 mm
Ultrasonic Frequency	75 kHz
Opening Angle	< 14 °
Service Life (T = +25 °C)	100000 h
Switching Hysteresis	30 mm

Electrical Data	
Supply Voltage	18...30 V DC
Current Consumption (U _b = 24 V)	< 50 mA
Switching Frequency	1,5 Hz
Response Time	< 334 ms
Temperature Range	-25...60 °C
Switching Outputs	2
Switching Output Voltage Drop	< 2,5 V
PNP Switching Output/Switching Current	100 mA
Analog Output	0...10 V/4...20 mA
Synchronous Mode	up to 40 sensors
Multiplex Mode	up to 16 sensors
Short Circuit Protection	yes
Reverse Polarity Protection	yes
Overload Protection	yes
Interface	IO-Link V1.0
Protection Class	III

Mechanical Data	
Setting Method	Menu (OLED)
Housing Material	Plastic
Degree of Protection	IP67
Connection	M12 × 1; 4/5-pin

Function	
Selectable menu language	yes
Password Protection	yes

Error Output	●
PNP NO/NC switchable	●
Analog Output	●
IO-Link	●

Connection Diagram No.	183
Control Panel No.	X2
Suitable Connection Technology No.	2 35
Suitable Mounting Technology No.	340

Display brightness may decrease with age. This does not result in any impairment of the sensor function.

Complementary Products

Analog Evaluation Unit AW02
IO-Link Master
PNP-NPN Converter BG2V1P-N-2M
Software

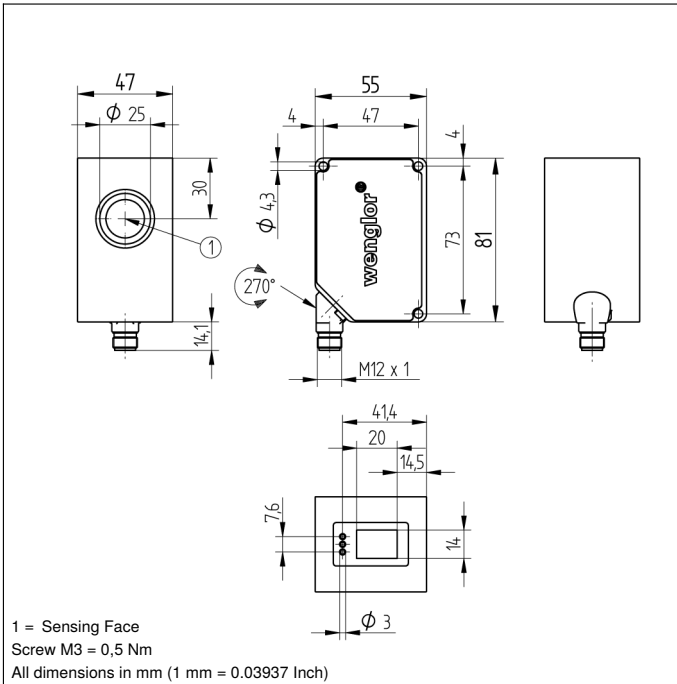

Ctrl. Panel



20 = Enter Button
22 = UP Button
23 = Down Button
60 = Display

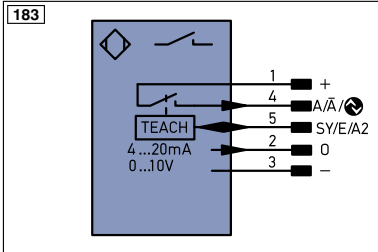

Legend		Legend		Legend	
+	Supply Voltage +	PT	Platinum measuring resistor	ENa	Encoder A
-	Supply Voltage 0 V	nc	not connected	ENb	Encoder B
~	Supply Voltage (AC Voltage)	U	Test Input	AMIN	Digital output MIN
A	Switching Output (NO)	U	Test Input inverted	AMAX	Digital output MAX
Ā	Switching Output (NC)	W	Trigger Input	AOK	Digital output OK
V	Contamination/Error Output (NO)	O	Analog Output	SY In	Synchronization In
ṽ	Contamination/Error Output (NC)	O-	Ground for the Analog Output	SY OUT	Synchronization OUT
E	Input (analog or digital)	BZ	Block Discharge	Out	Brightness output
T	Teach Input	AW	Valve Output	M	Maintenance
Z	Time Delay (activation)	a	Valve Control Output +		
S	Shielding	b	Valve Control Output 0 V		
RxD	Interface Receive Path	SY	Synchronization		
TxD	Interface Send Path	E+	Receiver-Line		
RDY	Ready	S+	Emitter-Line		
GND	Ground	≡	Grounding		
CL	Clock	SnR	Switching Distance Reduction		
E/A	Output/Input programmable	Rx+/-	Ethernet Receive Path		
IO-Link	IO-Link	Tx+/-	Ethernet Send Path		
PoE	Power over Ethernet	Bus	Interfaces-Bus A(+)/B(-)		
IN	Safety Input	La	Emitted Light disengageable		
OSSD	Safety Output	Mag	Magnet activation		
Signal	Signal Output	RES	Input confirmation		
Bl..D+/-	Ethernet Gigabit bidirect. data line (A-D)	EDM	Contactur Monitoring		
EN0..542Z	Encoder 0-pulse 0-0 (TTL)	ENa..542Z	Encoder A/Ā (TTL)		
		ENb..542Z	Encoder B/B̄ (TTL)		

Wire Colors according to DIN IEC 757

BK	Black
BN	Brown
RD	Red
OG	Orange
YE	Yellow
GN	Green
BU	Blue
VT	Violet
GY	Grey
WH	White
PK	Pink
GNYE	Green/Yellow

Characteristic response curve

Measurement of the sonic cone on a 100 x 100 mm plate

UMS603U035

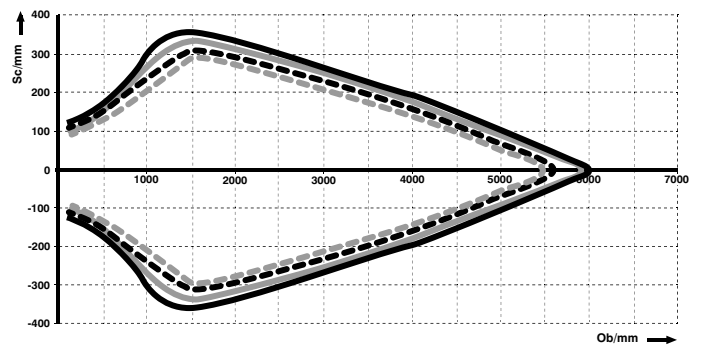

Ob = Object
Sc = Sonic cone width

- Standard
- - - Medium-width
- ... Narrow
- · - Extra-narrow

