

Floodlight

ZFFI09-03

Part Number



- Diffuse illumination with incident light mode
- Especially for through-beam operating mode
- Flashlight mode synchronizable with image processing

Technical Data

Optical Data	
Light Source	Infrared Light
Wave Length	850 nm
Radiance (continuous light mode)	~ 3,8 W/m ² sr
Radiance (flashlight mode)	~ 12,9 W/m ² sr
Electrical Data	
Supply Voltage	22...27 V DC
Current Consumption (U _b = 24 V)	< 900 mA
Temperature Range	0...50 °C
Reverse Polarity Protection	yes
Protection Class	III
Mechanical Data	
Luminous Field Length (L)	240 mm
Housing Material	Aluminum
Degree of Protection	IP42
Connection	M12 × 1; 4-pin
Connection Diagram No.	749
Connection Table No.	32
Suitable Connection Technology No.	2

The wenglor floodlight can be used either with through-beam or incident light operating mode. Transparent and reflective objects as well as object contours are illuminated well.

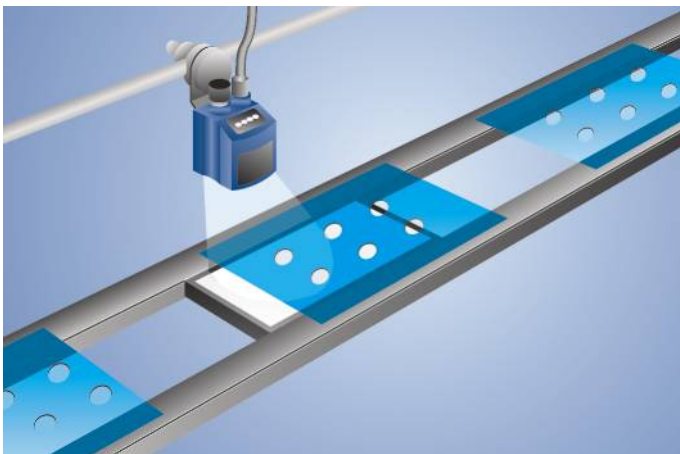

Complementary Products

Connection Cable BG2BSW1-08M, ZAV89V901, ZDCG001

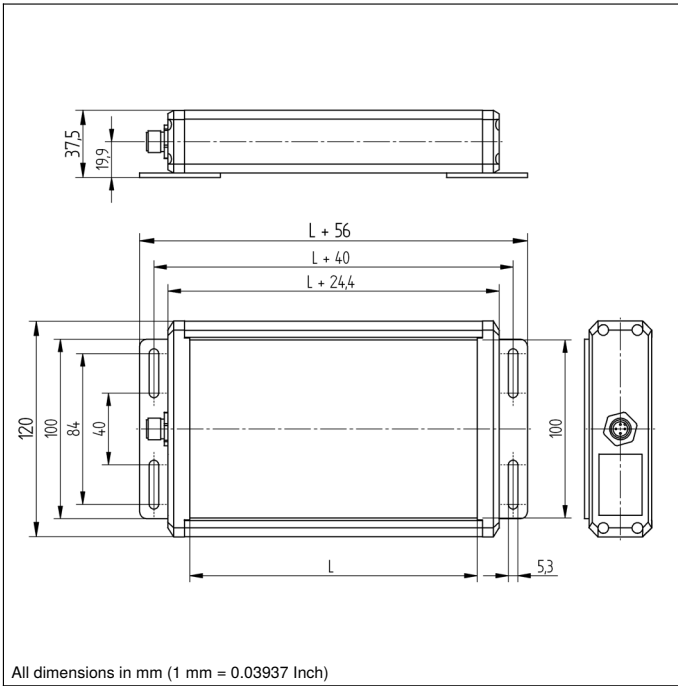
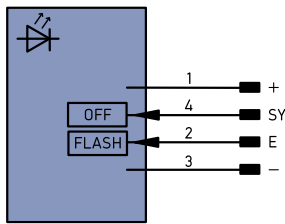
749

Legend

+	Supply Voltage +
-	Supply Voltage 0 V
~	Supply Voltage (AC Voltage)
A	Switching Output (NO)
Ā	Switching Output (NC)
V	Contamination/Error Output (NO)
ṽ	Contamination/Error Output (NC)
E	Input (analog or digital)
T	Teach Input
Z	Time Delay (activation)
S	Shielding
RxD	Interface Receive Path
TxD	Interface Send Path
RDY	Ready
GND	Ground
CL	Clock
E/A	Output/Input programmable
	IO-Link
PoE	Power over Ethernet
IN	Safety Input
OSSD	Safety Output
Signal	Signal Output
Bl..D +/-	Ethernet Gigabit bidirect. data line (A-D)
EN0-RS422	Encoder 0-pulse 0-0 (TTL)
PT	Platinum measuring resistor
nc	not connected
U	Test Input
Ū	Test Input inverted
W	Trigger Input
O	Analog Output
O-	Ground for the Analog Output
BZ	Block Discharge
AwV	Valve Output
a	Valve Control Output +
b	Valve Control Output 0 V
SY	Synchronization
E+	Receiver-Line
S+	Emitter-Line
≡	Grounding
SnR	Switching Distance Reduction
Rx +/-	Ethernet Receive Path
Tx +/-	Ethernet Send Path
Bus	Interfaces-Bus A(+)/B(-)
La	Emitted Light disengageable
Mag	Magnet activation
RES	Input confirmation
EDM	Contact Monitoring
ENAR5422	Encoder A/Ā (TTL)
ENBR5422	Encoder B/B̄ (TTL)

ENa	Encoder A
ENb	Encoder B
AMIN	Digital output MIN
AMAX	Digital output MAX
AOK	Digital output OK
SY In	Synchronization In
SY OUT	Synchronization OUT
Out	Brightness output
M	Maintenance

Wire Colors according to DIN IEC 757

BK	Black
BN	Brown
RD	Red
OG	Orange
YE	Yellow
GN	Green
BU	Blue
VT	Violet
GY	Grey
WH	White
PK	Pink
GNYE	Green/Yellow

